



**Township of Howick Council Agenda  
Tuesday, June 16, 2026, at 7:00 p.m.  
Howick Council Chambers**

**1. Call to Order**

**2. Confirmation of the Agenda**

**Recommended Motion:**

That the Council of the Township of Howick hereby adopts the June 19, 2026, Council Agenda as presented.

**3. Declaration of Pecuniary Interest under the “Municipal Conflict of Interest Act”**

**4. Minutes of Previous Meetings**

**Recommended Motion:**

That the Council of the Township of Howick hereby adopts the following minutes:

**4.1 [May 19, 2026, Council Meeting Minutes](#)**

**5. Public Meetings/Hearings**

**5.1 Meeting to Consider Engineer’s Report – [DRN-2026-04](#) Merkley Municipal Drain 2026**

**5.1.1 [Engineer’s Report](#)**

Project Coordinator Brandon Widner to present the Engineer’s Report to Council and those in attendance.

**5.1.2 Questions and Comments**

- Landowners in attendance
- Council

**5.1.3 Consideration of [Provisional By-law 43-2026](#)**

**Recommended Motion:**

That leave be given to introduce By-law # 43-2026, being a by-law to provisionally adopt the engineer’s report for the Merkley Municipal Drain 2026, and that it now be read a first and second time this 16<sup>th</sup> day of June, 2026.

#### 5.1.4 Date of Court of Revision and instruction to Tender

##### **Recommended Motion:**

That the Court of Revision for the Merkley Municipal Drain 2026 be set for July 14, 2026 at 11:00 a.m. and the project be tendered with results to be presented on August 11, 2026 pending no appeals.

*Council to appoint 2 members to Court of Revision, with one being the Chair. A Third member of Court of Revision will be appointed from the Municipality of Morris-Turnberry.*

#### 5.2 2026 Insurance Renewal Presentation

##### **FIN-2026-18, Insurance Renewal July 2026 to July 2027**

##### **Recommended Motion:**

That Howick Council of the Township of Howick approve the municipal insurance coverage presented in the July 1, 2026, to July 1, 2027, Renewal Report by Intact Insurance at a cost of \$161,037.

### 6. Delegations and/or Presentations

#### 7. Consent Agenda

Items on the Consent Agenda are considered routine and are enacted in one motion. Prior to the motion being voted on, any Council Member may request that one or more items be removed from the Consent Agenda and discussed and/or voted on separately.

##### **Recommended Motion:**

That Consent Agenda item 7.1 be received for information and approved.

##### **7.1 FIN-2026-17, May 13 to June 11, 2026 Accounts Payable For Information Only.**

#### 8. Regular Agenda

##### 8.1 Planning – Huron County Planner

#### 9. Municipal Drains - Drainage Superintendent Scott Richardson

#### 10. Staff Reports

##### 10.1 Chief Building Official Ed Podniewicz

##### 10.2 Manager of Development and Protective Services/Fire Chief - Josh Kestner

### 10.3 Manager of Public Works – Scott Price

#### 10.3.1 **PW-2026-15, Hot Mix Paving Tender Results**

**Recommended Motion:**

That Howick Council receives report PW-2026-15, Hot Mix Paving Tender Results for information;

And That Council authorize Howick Township to enter into an agreement with the Municipality of South Bruce for 50% of the cost of Hot Mix Paving Huron-Bruce Road (\$89,142.50) and 100% of the cost of Hot Mix Paving George Street, Gorrie (\$45,420.00), for the total tendered amount of \$134,562.50 plus unrecoverable HST, as outlined in South Bruce Tender No. PW-2026-03;

And That Council give first, second, and third and final reading to By-law No. 44-2026, being a By-law to Authorize the Entering into and Execution of an Agreement between the Municipality of South Bruce and the Corporation of the Township of Howick;

And That Council authorize the Manager of Public Works to execute the agreement and all associated documents for the above-mentioned projects.

#### 10.3.1 **PW-2026-16, Roadside Flail Mower Tender Results**

**Recommended Motion:**

That Howick Council receives report PW-2026-16, Roadside Flail Mower Tender Results for information;

And that Council award Tender PW-2026-03 to Midwestern Equipment (Listowel) Ltd. in the amount of \$21,355.87 (plus unrecoverable HST) for the purchase of a Roadside Flail Mower.

And that the CAO/Clerk and Reeve be authorized to sign and execute the agreement and all relevant documents.

### 10.4 Manager of Recreation and Facilities - Brady Ropp

### 10.5 Treasurer/Manager of Finance - Amy Van Meeteren

### 10.6 CAO/Clerk Caitlin Gillis

#### 10.6.1 **ADM–2026-10, Fordwich Parkland Funds**

**Recommended Motion:**

That Howick Council authorize the transfer of \$18,000.00 from Parkland Reserves to the Fordwich Park Board for repairs and

resurfacing of the Tennis Court.

## 11. Committee and Board Reports

- 11.1 [Howick Homecoming](#) – Meeting Minutes April 7, 2026
- 11.2 [Howick Homecoming](#) – Meeting Minutes May 26, 2026
- 11.3 [Belmore Arena Board](#) – Meeting Minutes March 16, 2026
- 11.4 [Belmore Arena Board](#) – Meeting Minutes April 20, 2026

## 12. Correspondence

- 12.1 [Ministry of Municipal Affairs and Housing](#) – Protecting Ontario’s Streets and Communities Act, 2026 (Bill119)
- 12.2 [Ministry of the Attorney General](#) – Follow-up to Updates to “Tailgate Event” Permits
- 12.3 [Avon Maitland District School Board](#) – Meeting Highlights May 26, 2026
- 12.4 [Huron County Federation of Agriculture](#) – Warden Caucus Comments
- 12.5 [Ministry of the Environment, Conservation and Parks](#) – Improving Ontario’s Conservation Authority System
- 12.6 [Maitland Conservation](#) – Meeting Minutes April 15, 2026
- 12.7 [Drinking Water Source Protection](#) – Municipal Newsletter
- 12.8 [Huron OPP Detachment Board](#) – Meeting Minutes
- 12.9 [The Corporation of the Municipality of Wawa](#) – Sustainable Provincial Grant Funding for Fire Services in Ontario
- 12.10 [Corporation of the Municipality of Calvin](#) – Request for Provincial Review of CVA- Based Apportionment for Shared Municipal and Provincially Mandates Services
- 12.11 [The Town of Plympton – Wyoming](#) – Support for Sustainable Provincial Grant Funding for Fire Services in Ontario
- 12.12 [Ministry of Natural Resources](#) – Ontario’s Flooding Strategy

## 13. Unfinished Business

## 14. Council Reports

- 14.1 Council Member Reports
  - [Reeve’s Verbal Update from County Council](#)
  - [Verbal Update from Council Members](#)
- 14.2 Requests by Members

**14.3 Notice of Motions**

**14.4 Announcements**

**15. Other Business**

**16. Enactment of By-laws – First, Second & Third Reading**

**Recommended Motion:**

That By-laws 43-2026, 44-2026, and 45-2026 all receive first, second, third and final reading and are finally passed.

**16.1 By-law 43-2026**

That the Council of the Township of Howick give first and second reading to By-law 43-2026 to provisionally adopt a by-law to provide drainage work in the Township of Howick for the improvement to the Merkle Municipal Drain

**16.2 By-law 44-2026**

That the Council of the Township of Howick give first, second third and final reading to By-law 44-2026;

Being a By-law to Authorize the Entering into and Execution of an Agreement between the Corporation of the Township of Howick and the Corporation of the Municipality of South Bruce for Hot Mix Paving as outlined in South Bruce Tender Documents PW-2026-03

**16.3 By-law 45-2026**

That the Council of the Township of Howick give first, second third and final reading to By-law 45-2026;

Being a By-law to Authorize the Entering into and Execution of an Agreement Between the Corporation of the Township of Howick and Midwestern Equipment (Listowel) Ltd. For the Supply and Delivery of one (1) Roadside Flail Mower

**17. Confirming By-law**

**17.1 By-law 46-2026**

That the Council of the Township of Howick give first, second, third and final reading to By-law 46-2026;

Being a By-law to Confirm the Proceedings of the Council meeting held on June 16, 2026.

**18. Adjournment**

**Recommended Motion:**

That the Council of the Township of Howick adjourn the June 16, 2026 Regular Council meeting at \_\_:\_\_ p.m.



**Township of Howick Council Minutes  
Tuesday, May 19, 2026, at 7:00 p.m.  
Howick Council Chambers**

**1. Call to Order**

Reeve Harding called the meeting to order at 7:00 p.m. and welcomed everyone in attendance.

**2. Confirmation of the Agenda**

Reeve Harding noted one minor amendment to tonight's agenda. Under item 7.1, the Delegation from Huron Hospice has been moved to correspondence.

**Moved by: Councillor Grimes**

**Seconded by: Deputy Reeve Gibson**

That the Council of the Township of Howick hereby adopts the May 19, 2026, Council Agenda as presented.

**Carried.**

**3. Declaration of Pecuniary Interest under the "Municipal Conflict of Interest Act"**

**None Declared**

**4. Minutes of Previous Meetings**

**Moved by: Councillor Rognvaldson**

**Seconded by: Deputy Reeve Gibson**

That the Council of the Township of Howick hereby adopts the following minutes:

**4.1 May 5, 2026, Council Meeting Minutes**

**Carried.**

**5. Public Meetings/Hearings**

**6. Delegations and/or Presentations**

**6.1 Maitland Valley Conservation Authority – Phil Beard**

Reeve Harding called upon MVCA General Manager/Secretary-Treasurer Phil Beard to give his presentation to council. Phil explained that his presentation will go over their programs and services that will be provided in the new

agreement and that Maitland Valley Conservation Authority is looking for feedback on the agreement that was signed 4 years ago. The programs and services for Howick are outlined in the agreement; there has been a slight change of wording in the agreement. The province does not allow for the word "levy" to be used, it has been changed in the agreement to read "cost apportionment"

Phil announced that the Wawanosh Park Conservation Area Campground has been permanently closed due to safety concerns of flood risk. The Huron Clean Water Project is also coming to an end. There will be no new project grants available after the end of 2026. The existing funds will be disbursed throughout the County. Final distribution decision is yet to be made.

The Budget process will remain the same for 2027, and the work plan will be completed at the end of the year. The board will be finalized at the end of October due to the election. The new proposed boundary for the conservation authority will stretch from Barrie to Lambton County up to Port Elgin. Representative will be from the County level and there have been talks that it could possibly be representation by population. MVCA's continued vision is to keep our environment healthy, and the continued watershed stewardship service. Over the past 4 years, MVCA has led 28 stewardship projects consisting of cover crops, naturalizing, Huron Clean Water program. Maitland Valley has 28 Conservation Areas; most are used for passive recreation.

Maitland Valley Staff are looking for input on services and programs over the next 4 years. There is going to be loss of local representation and less than 2% of the funding comes from the province. Council voiced frustration over consolidation and said it will not save us any money. The current agreement expired June 16, 2026. Council is not prepared to sign the agreement at this time, will review and provide feedback.

## **7. Consent Agenda**

Items on the Consent Agenda are considered routine and are enacted in one motion. Prior to the motion being voted on, any Council Member may request that one or more items be removed from the Consent Agenda and discussed and/or voted on separately.

**Moved by: Deputy Reeve Gibson**

**Seconded by: Councillor Grimes**

That Consent Agenda items 7.1 and 7.4 be received for information and approved.

**7.1 PW-2026-14, May Department Update  
For Information Only.**

**7.2 REC-2026-09, Department Update  
For Information Only.**

**7.3 FIN-2026-15, Accounts Payable Apr 10- May 12, 2026  
For Information Only.**

**7.4 ADM-2026-09, Department Update  
For Information Only.**

**Carried.**

**8. Regular Agenda**

**8.1 Planning – Huron County Planner**

**9. Municipal Drains - Drainage Superintendent Scott Richardson**

**9.1 DRN -2026-02, No. 20 Municipal Drain**

Drainage Superintendent Scott Richardson advised that the Township received a request under section 78 to complete upgrades on Drain No. 20 and bring it up to a modern standard with sufficient capacity. The Township has chosen Dietrich Engineering Ltd. to prepare a new report with a design cost estimate and maintenance schedule. An onsite meeting was held on October 20, 2025, with a meeting held at the Howick Township Office on March 10, 2026 to review preliminary design and cost estimate. Scott welcomed Chris Dietrich from Dietrich Engineers Ltd. to present the engineer's report.

The existing tile drain was constructed in 1944. The new drain will consist of approx. 916 meters of 300 mm to 525 mm diameter field tile and HDPE pipes, 5 concrete catch basins and 1 concrete junction box. The proposed original capacity of drainage was 38mm/24 hours, however landowners agreed to upgrade to 50mm design. Total cost estimate for the whole project is \$227,900.00. There were no questions from Council.

**Moved by: Councillor Grimes**  
**Seconded by: Councillor Rognvaldson**

That Howick Council considers the attached report under Section 78 of the Drainage Act, for the improvement of the No. 20 Municipal Drain, as prepared by Dietrich Engineering April 6, 2026;

And That Howick Township Council set the sitting of the Court of Revision for appeals on assessment to be held at the regular council meeting on June 16th at 6:30pm;

And Further That Howick Township Council appoint three Council members from the Township of Howick, being Councillor Grimes, Deputy Reeve Gibson, and Councillor Hargrave (Chair), to the Court of Revision for the No. 20 Municipal Drain;

And that Howick Township Council give first and second reading and provisionally adopt By-law 41-2026, being a by-law to provide for a drainage works cited as the No. 20 Municipal Drain By-law.

**Carried.**

**9.2 DRN -2026-03, Amending Municipal Drain By-laws: Drain #10, Metcalfe-Wright Municipal Drain, and Weber No. 7 Drain**

This report is to adopt the amending drainage By-laws for the Metcalfe-Wright, No. 10 and Weber No. 7 Municipal Drains. This work has already been completed, amending these specific bylaws allows us to invoice the landowners for the work.

**Moved by: Deputy Reeve Gibson**  
**Seconded by: Councillor Grimes**

That Howick Council receive report DRN-2026-03 for information;

And That Council adopt the drainage amending By-laws for the Metcalfe-Wright, Swan Culvert Crossing – Metcalfe-Wright, Weber No. 7 and the No. 10 Municipal Drains.

**Carried.**

## **10. Staff Reports**

### **10.1 Chief Building Official Ed Podniewicz**

### **10.2 Manager of Development and Protective Services/Fire Chief - Josh Kestner**

#### **10.2.1 DPS-2026-14, Hiring Recruit Firefighter**

Manager of Development and Protective Services /Fire Chief Josh Kestner presented his report to Council. Hiring recruit fire fighter, Sara Whitehead effective May 19, 2026. Council approved hiring six Recruit Fire Fighters on January 27, 2026. One of the Recruit Firefighters submitted his resignation leaving one position open. Sara Whitehead has completed the Pre-Service Program at Lambton College and is working towards her NFPA 1001 and 1072 in June of 2026. She will be joining the department as a certified Firefighter. Staff anticipate there will be 3 or 4 more vacant positions at the end of the year due to retirements.

**Moved by: Councillor Rognvaldson**  
**Seconded by: Councillor Grimes**

That the Council of the Township of Howick approve the hiring of Sara Whitehead as a Recruit Firefighter with the Howick Township Fire Department effective May 19, 2026.

**Carried.**

#### **10.2.2 DPS-2026-15, Workstation Purchase from Building Reserve**

Operations Administrative Assistant Jess Miller supports the Development and Protective Services Department which includes the Chief Building Official. Right now, Jess is primarily working out of the Fire Station where her desk is. Staff are requesting for a desk and equipment to outfit the workstation to be purchased using the building reserves. When she is assisting the CBO at the Municipal Office, she does not currently have a designated workstation. Ed has agreed to put a second desk in his office, and

this is the perfect opportunity for the planner to have a desk when they are in the office as well. The building department does have a healthy reserve. Holst office supplies have been contacted and provided an estimate of \$2,500.00 depending on promotions at that time, plus monitors, docking station, keyboard, mouse, and a chair.

**Moved by: Councillor Rognvaldson**  
**Seconded by: Councillor Grimes**

That the Council of the Township of Howick approve up to \$4,000.00 to be drawn from the Building Department reserve for the purchase of an additional workstation to be used by the Operations Administrative Assistant when supporting the Chief Building Official at the Howick Municipal Office

**Carried.**

### **10.2.3 DPS-2026-16, Landfill Amnesty Day**

There has been ongoing consultation between the Public Works Manager, Manager of Recreation and Facilities, Community Improvement and Beautification Committee as well as Gorrie Village Management regarding cleaning up Howick in advance of the 170<sup>th</sup> Homecoming celebrations. Holding a landfill amnesty day will provide residents with further incentive to clean up their properties. There was also discussion about bins being placed in each community as a central drop off, however a staff member would need to monitor what gets dropped off and this would increase staff time. The intention is for residents and businesses to clean up around their properties outside. Regular household garbage will not be accepted. There will be an option for people who have physical issues or elderly residents staff would complete pick ups that are prearranged. All others would be directed to take items directly to the landfill. Staff would like Council to discuss and see if there is any interest in this and determine what will be accepted at the landfill. New landfill attendant has been at the landfill since last December and understands what is accepted. Council likes the idea and would be willing to collect during regular staff time. Senior staff to determine what is accepted – emphasis on this is not a hazardous waste day but a beautification day.

**Moved by: Councillor Rognvaldson**  
**Seconded by: Councillor Grimes**

That the Council of the Township of Howick receive report DPS-2026-16 for information and discussion;

And that Council approve the waiving of all landfill fees for approved materials on Saturday June 13, 2026, to promote

cleanup of properties in Howick ahead of the 170<sup>th</sup> Howick Homecoming

**Carried.**

**10.3 Manager of Public Works – Scott Price**

**10.4 Manager of Recreation and Facilities - Brady Ropp**

**10.5 Treasurer/Manager of Finance - Amy Van Meeteren**

**10.5.1 FIN-2026-16, Appoint Officials, Members of Committees and Boards**

Treasurer/ Manager of Finance called upon to present her report. Staff are updating the Boards and Committees By-law to reflect updates to board membership. At the end of 2025, two members resigned from the Fordwich Cemetery Board. Pete King has submitted his interest in becoming Chair of the Fordwich Cemetery Board with Bill Miller as Treasurer. Since the agenda was published, the By-law was amended to update the South Bruce representative on the Belmore Community Arena Board. Councillor Rognvaldson provided an update that Sustainable Huron no longer exists. This committee was cut during the budget process at Huron County.

**Moved by: Councillor Grimes**

**Seconded by: Deputy Reeve Gibson**

That the Council of the Township of Howick pass by-law 41-2026; being a by-law to appoint Officials, Members or Committees and Boards for the Township of Howick.

**Carried.**

**10.6 CAO/Clerk Caitlin Gillis**

**11. Committee and Board Reports**

Councillor Grimes provided an update on the Wroxeter Hall Board. Tony Clarke came back on the board as Chair. Councillor Grimes has stepped down from the interim Chair position. The Annual Fish Fry is coming up on Friday, June 12, 2026. Hoping that the cement patio will be complete out back of the hall prior to the event.

**Moved by: Deputy Reeve Gibson**

**Seconded by: Councillor Grimes**

That Howick Council adopt the following Committee and Board Minutes:

**11.1 Wroxeter Hall Board Meeting Minutes – April 2, 2026**

**Carried.**

## **12. Correspondence**

### **12.1 Fordwich & Community Parks Association – re. Request for Municipal Significance**

**Moved by: Deputy Reeve Gibson  
Seconded by: Councillor Grimes**

That the Council of the Township of Howick hereby declares the Howick Minor Ball Day scheduled for June 13, 2026, from 10:00 a.m. to 11:00 p.m. at the Fordwich Ball Park and hosted by the Fordwich Community Parks Association, to be of municipal significance.

**Carried.**

### **12.2 Howick Homecoming Committee – re. Request for Municipal Significance**

**Moved by: Councillor Rognvaldson  
Seconded by: Councillor Grimes**

That the Council of the Township of Howick hereby declares Howick 170<sup>th</sup> Homecoming scheduled for July 3, 2026, at 2:00 p.m. to Sunday July 5, 2026 at 5:00 p.m. at the Howick Community Centre to be of municipal significance.

**Carried.**

### **12.3 Saugeen Hospice Inc. – re. Cash Calendar Sales Cash calendar licence require letters from all municipalities that they have permission to sell within the township**

**Moved by: Deputy Reeve Gibson  
Seconded by: Councillor Grimes**

That the Council of the Township of Howick hereby grants Saugeen Hospice Inc. permission to sell Cash Calendar tickets within the limits of Howick Township beginning this summer to support their ongoing activities.

**Carried.**

### **12.4 Western Ontario Wardens Caucus- Support of Finlay's Law on Emergency Room Reform**

**Moved by: Deputy Reeve Gibson  
Seconded by: Councillor Rognvaldson**

That the Council of the Township of Howick endorse the resolution received from Western Ontario Wardens' Caucus requesting the Provincial Ministry of Health to take immediate action to reduce ER wait times with consideration for the importance of enhanced ER triage protocols and increased funding to strengthen emergency readiness

Carried.

- 12.5 Gorrie Village Management Committee – Meeting Minutes May 12, 2026
- 12.6 Ministry of Municipal Affairs and Housing – Stormwater Fees Regulations
- 12.7 Municipal Property Assessment Corporation – 2025 Annual and Performance Report
- 12.8 Municipal Property Assessment Corporation – 2025 Financial Statements
- 12.9 Avon Maitland District School Board – Meeting Highlights April 28, 2026
- 12.10 Huron County Library – 2025 Annual Report
- 12.11 Huron Perth Public Health – Food Insecurity Letter and Report 2026
- 12.12 Maitland Valley Conservation Authority –March 18, 2026 Minutes
- 12.13 The Corporation of the County of Wellington – Notice of Adoption
- 12.14 Ministry of the Environment Conservation and Parks – Proposed Environmental Assessment Act
- 12.15 Ministry of the Environment Conservation and Parks – Requirements for waste disposal site service area and fill rate changes
- 12.16 Ministry of the Environment Conservation and Parks – Minister’s direction under section 1.14 of the Conservation Authorities Act
- 12.17 Huron County Pride Festival – Invitation
- 12.18 Oxford County – Resolution re. Association of Ontario Road Supervisors

### 13. Unfinished Business

### 14. Council Reports

#### 14.1 Council Member Reports

##### **Reeve’s Verbal Update from County Council**

Reeve Harding commented that he is happy to see that the Treasurers in Huron County are meeting to discuss the Buy Ontario Act, 2025.

##### **Verbal Update from Council Members**

#### 14.2 Requests by Members

#### 14.3 Notice of Motions

#### 14.4 Announcements

### 15. Other Business

The Treasurers of Huron County will meet on June 10, 2026, to discuss the Buy Ontario Act, 2025. An update will be provided at a future Regular Council Meeting.

**16. Enactment of By-laws – First, Second & Third Reading**

**Moved by: Deputy Reeve Gibson**  
**Seconded by: Councillor Rognvaldson**

That By-laws 37-2026, 38-2026, 39-2026, 41-2026, and 42-2026 all receive first, second, third and final reading and are finally passed.

**Carried.**

**Moved by: Deputy Reeve Gibson**  
**Seconded by: Councillor Rognvaldson**

That By-law 40-2026 be given first and second reading and provisionally adopt a by-law to provide for drainage work in the Township of Howick for the re-construction of Municipal Drain No. 20.

**Carried.**

**16.1 By-law 37-2026**

That the Council of the Township of Howick give first, second, third and final reading to By-law 37-2026;

Being a By-law to amend By-law No. 53-2021 (Metcalf-Wright Municipal Drain) of the Township of Howick, to provide for raising a greater amount than provided therein

**16.2 By-law 38-2026**

That the Council of the Township of Howick give first, second, third and final reading to By-law 38-2026;

Being a By-law to amend By-law No. 55-2024 (Weber No. 7 Municipal Drain) of the Township of Howick, to provide for raising a lessor amount than provided therein

**16.3 By-Law 39-2026**

That the Council of the Township of Howick give first, second, third and final reading to By-law 39-2026;

Being a By-law to amend By-law No. 41-2025 (No.10 Municipal Drain) of the Township of Howick, to provide for raising a greater amount than provided therein

**16.4 By-law 40-2026**

That the Council of the Township of Howick give first and second reading to By-law 40-2026 provisionally adopt a by-law to provide for drainage work in

the Township of Howick for the re-construction of Municipal Drain No. 20

**16.5 By-law 41-2026**

That the Council of the Township of Howick give first, second, third and final reading to By-law 41-2026;

Being a By-law to appoint officials, members or committees and boards and other such persons as required

**17. Confirming By-law**

**17.1 By-law 42-2026**

**Moved by: Councillor Rognvaldson**

**Seconded by: Councillor Grimes**

That the Council of the Township of Howick give first, second, third and final reading to By-law 42-2026;

Being a By-law to Confirm the Proceedings of the Council meeting held on May 19, 2026.

**Carried.**

**18. Adjournment**

**Moved by: Councillor Hargrave**

**Seconded by: Councillor Grimes**

That the Council of the Township of Howick adjourn the May 19, 2026, Regular Council meeting at 7 :58 p.m.

**Carried.**

---

**Reeve, Doug Harding**

---

**CAO/Clerk Caitlin Gillis**

# Staff Report to Council

**Report From:** Scott Richardson, Drainage Superintendent

**Meeting Date:** June 16<sup>th</sup>, 2026

**Report:** Merkley Municipal Drain

## Recommendations:

That Howick Council received report DRN-2026-04, Merkley Municipal Drain for Information;

And That leave be given to introduce By-law # 43-2026, being a by-law to provisionally adopt the engineer's report for the Merkley Municipal Drain 2026, and that it now be read a first and second time this 16<sup>th</sup> day of June, 2026.

And That the Court of Revision for the Merkley Municipal Drain 2026 be set for July 14, 2026 at 11:00 a.m. and the project be tendered with results to be presented on August 11, 2026 pending no appeals.

## Report Overview

<b>Purpose of Report</b>	The purpose of this report is for council to consider the drainage report, prepared by Spriet Associates, for the Merkley Municipal Drain
<b>Council Priority Alignment</b>	Safe & Reliable Infrastructure
<b>Consultations</b>	<b>Brandon Widner P. Eng, Spriet Associates</b>
<b>Attachment(s) to Report</b>	Merkley Municipal Drain Engineer's Report Draft By-law 43-2026

## Report Highlights.

- The township received a request for improvement under Section 78 of the Staff Report DRN-2026-04 1 of 2

Drainage Act to complete upgrades by enclosing 2 sections of open drain, installation of a new culvert crossing and maintenance by brushing and dredging of open sections left on the drain.

- The township has appointed Spriet Associates, to prepare a new report with a design, cost estimates and future maintenance schedule.

## **Context and Background**

- An on-site meeting was held on March 25<sup>th</sup>, 2026.
- An information meeting was held on May 4<sup>th</sup>, 2026 at the Howick Township office. This meeting was to review the preliminary design with cost estimates.
- The township has an estimated assessment of \$3,345.00 for a catch basin, south of Salem Road.

## **Discussion and Staff Recommendation(s)**

I would like to call on Brandon Widner of Spriet Associates to present his final report.

## **Impact Analysis**

The Township is responsible for \$3,345.00 for this project.

## **Linkages**

[Merkley Municipal Drain – Engineer’s Report](#)

[Draft By-law 43-2026](#)

---

**Respectfully submitted,**

**Scott Richardson, Drainage Superintendent**

**MERKLEY DRAIN**  
**Township of Howick**



**SPRIET**  
**ASSOCIATES**  
ENGINEERS & ARCHITECTS  
155 York Street  
London, Ontario N6A 1A8  
Tel. (519) 672-4100  
Fax (519) 433-9351  
Email: [mail@spriet.on.ca](mailto:mail@spriet.on.ca)  
[www.spriet.on.ca](http://www.spriet.on.ca)

London, Ontario  
May 15, 2026

## **MERKLEY DRAIN**

### **Township of Howick**

To the Mayor and Council of  
the Township of Howick

Mayor and Council:

We are pleased to present our report on the reconstruction and reassessment of parts of the Merkley Municipal Drain serving parts of Lots 10 to 16, Concession A in the Township of Howick and parts of Lots 10 to 12, Concession C (geographic Turnberry) in the Municipality of Morris-Turnberry. The total watershed area contains approximately 112 hectares.

#### **AUTHORIZATION**

This report was prepared pursuant to Section 78 of the Drainage Act. Instructions were received from your Municipality with respect to a motion of Council. The work was initiated by a request signed by some of the affected landowners.

#### **HISTORY**

The Merkley Drain was originally constructed pursuant to a report submitted by W.D. Colby, P. Eng., dated November 21, 1955, and consisted of approximately 2,134 lineal meters of open drain located from the road crossing at Belmore Road (County Road No. 12) and continued south-easterly to its outlet at Drain No. 19 and in Lot 16, Concession A.

The drain was later improved pursuant to a report submitted by H.M. Gibson, P. Eng., dated July 15, 1970, and consisted of approximately 640 lineal meters of 150mm to 200mm diameter field tile and reconstruction of the existing open drain.

#### **EXISTING DRAINAGE CONDITIONS**

A site meeting was held on March 25, 2026 with respect to the project and, through later discussions, the owners reported the following:

- that the owner, J. Mulder (Roll No. 032-10), indicated their desire to enclose their portion of the drain to improve the workability of their land
- that the owner, B. & D. Merkley (Roll No. 900-029), indicated their desire to enclose the portion of the tile in their lands to improve the workability of their lands

## EXISTING DRAINAGE CONDITIONS (cont'd)

- that the owner, S. & K. Van Engen (Roll No. 900-030), indicated that they have an existing crossing on their lands but are not looking for an improvement at this time
- that other owners were also in attendance but not looking for an improvement at this time

A field investigation and survey were completed. Upon reviewing our findings we note the following:

- that the existing drain has not been maintained in the recent years and portions of it are overgrown and silted in
- that the requested enclosure is permissible but the downstream request by J. Mulder (Roll No. 032-10) does require offsetting from the Department of Fisheries and Oceans (DFO)
- that the existing road crossing under Salem Road is in decent condition and does not require replacement at this time

Preliminary design, cost estimates, and assessments were prepared and an informal public meeting was held on May 4, 2026 to review the findings and preliminary proposals. Further input and requests were provided by the affected owners at that time and at later dates. Based on the proposed design it was decided to proceed with the report.

## DESIGN CONSIDERATIONS

The Drainage Coefficient method contained in "DRAINAGE GUIDE FOR ONTARIO", Publication 29 by the Ontario Ministry of Agriculture, Food, and Agribusiness (OMAFRA) is typically used to design municipal drains. The Drainage Coefficient defines a depth of water that can be removed in a 24-hour period and is expressed in millimetres per 24 hours. The coefficient used to design this drain with respect to capacity was 38.1mm per 24 hours.

We would like to point out that there have been indications of sandy, mucky soil conditions and this region is known to have stones present. It should be noted that no formal soil investigation has been made, with this information being provided by the owners.

The proposed design and report have been generally completed using the "GUIDE FOR ENGINEERS WORKING UNDER THE DRAINAGE ACT IN ONTARIO" OMAFA Publication 852.

## RECOMMENDATIONS

We are therefore recommending the following:

- that the existing drain be enclosed in the lands of J. Mulder (Roll No. 032-10) for a total length of 208 lineal meters and that a wetland feature be constructed at the bottom end of the works as an offsetting feature and be included in this portion in compliance with the Fisheries Act authorization by the DFO. This wetland will be approximately 35 meters in length from the junction of Drain No.19



**RECOMMENDATIONS** (cont'd)

- that quarry stone riprap be installed around the upstream end of the 1200mm diameter pipe on Salem Road
- that the existing open drain upstream of Salem Road, north through the lands of G. Van Engen (Roll No. 900-031) and S. & K. Van Engen (Roll No. 900-030), be reconstructed and brushed for a total length of 691 lineal meters
- that the existing culvert in the lands of S. & K. Van Engen (Roll No. 900-030) be replaced as it lacks sufficient depth for upstream lands
- that the existing drain in the lands of B. & D. Merkley (Roll No. 900-029) be enclosed for a total length of 651 lineal meters
- that the existing open drain in the lands of I. Kaounis (Roll No. 900-027) be reconstructed and brushed to provide outlet for the upstream lands for a total length of 518 lineal meters
- that the existing drain located in the Township of Howick be officially abandoned from municipal status pursuant to Section 19 of the Drainage Act

**ENVIRONMENTAL CONSIDERATIONS AND MITIGATION MEASURES**

There are no significant wetlands or sensitive areas within the affected watershed area or along the route of the drains. The proposed construction of the Merkley Drain includes quarry stone outlet protection and surface inlets which greatly help reduce the overland surface flows and any subsequent erosion. A temporary flow check of silt fencing is to be installed in the ditch downstream of the tile outlet for the duration of the construction.

We have reviewed this project with the Maitland Valley Conservation Authority (MVCA), and they indicated that they would issue a permit when required. They also provided a planting recommendations to assist with the offsetting requirements required by the DFO for the FAA.

We have reviewed the proposed work with the DFO, File No. 24-HCAA-01532. This resulted in a Fisheries Act Authorization being applied for, which entailed providing an offsetting plan, a letter of credit for the offsetting features, and a monitoring plan to monitor the project two years after completion of the construction.

We are also recommending that the following erosion and sediment control measures be included as part of our reconstruction proposal to help mitigate any potential adverse impacts of the proposed drainage works on water quality and fishery habitat:

- timing of construction is to be only at times of low or no flow
- various sediment basins are to be constructed along the course of the drain at the locations specified on the plan and these basins are to be maintained by the Township of Howick
- a temporary flow check of silt fencing is to be installed for the duration of the construction at the bottom end of the ditch reconstruction

## ENVIRONMENTAL CONSIDERATIONS AND MITIGATION MEASURES (cont'd)

- a 3 meter wide grassed buffer strip between the top of the bank and any adjacent cultivated lands on the working side of the ditch is to be incorporated and/or be constructed in accordance with the attached plans

It is to be noted that both the existing and newly vegetated banks as well as the existing natural and newly created buffer strips along each side of the ditch are permanent parts of the Merkley Municipal Drain and shall not be disturbed or destroyed.

## SUMMARY OF PROPOSED WORK

The proposed work consists of approximately 1,204 lineal meters of open ditch reconstruction including quarry stone rip-rap bank protection, bank seeding, and construction of farm culverts; approximately 853 lineal meters of 675mm (27") to 875mm (33") diameter concrete field tile, including related appurtenances, and the construction of a wetland at the outlet to Drain No. 19.

## SCHEDULES

Four schedules are attached hereto and form part of this report, being Schedule 'A' - Allowances, Schedule 'B' - Cost Estimate, Schedule 'C' - Assessment for Construction, and Schedule 'D' - Assessment for Maintenance.

Schedule 'A' - Allowances. In accordance with Sections 29 and 30 of the Drainage Act, allowances are provided for right-of-way and damages to lands and crops along the route of the drain as defined below.

Schedule 'B' - Cost Estimate. This schedule provides for a detailed cost estimate of the proposed work which is in the amount of \$318,000.00. This estimate includes engineering and administrative costs associated with this project.

Schedule 'C' - Assessment for Construction. This schedule outlines the distribution of the total estimated cost of construction over the roads and lands which are involved.

Schedule 'D' - Assessment for Maintenance. In accordance with Section 38 of the Drainage Act, this schedule outlines the distribution of future repair and/or maintenance costs for portions of, or the entire drainage works.

Drawing No.'s 1 and 2, Job No. 226038, and specifications form part of this report. They show and describe in detail the location and extent of the work to be done and the lands which are affected.

## ALLOWANCES

**DAMAGES:** Section 30 of the Drainage Act provides for the compensation to landowners along the drain for damages to lands and crops caused by the construction of the drain.

## ALLOWANCES (cont'd)

The amounts granted are based on the following:

- a) for closed drain installed with wheel machine - \$3,613.00/ha.
- b) for open ditch work with excavated material levelled adjacent to drain - \$4,647.00/ha.

These base rates are multiplied by the hectares derived from the working widths shown on the plans and the applicable lengths.

**RIGHT-OF-WAY** Section 29 of the Drainage Act provides for an allowance to the owners whose land must be used for the construction, repair, or future maintenance of a drainage works. Under this report no allowance for right-of-way has been given to J. Mulder (Roll No. 900-032-10) or B. & D. Merkley (Roll No 900-029) on the Main Drain as the area gained by enclosing in the lands of the open drain is deemed sufficient and transferrable to the new closed drain.

For tile drains where the owners will be able to continue to use the land, the allowance provides for the right to enter upon such lands, and at various times for the purpose of inspecting such drain, removing obstructions, and making repairs. Also, the allowance provides for the restrictions imposed on those lands to protect the right-of-way from obstruction or derogation. The amount granted for right-of-way on tile drains is based on a percentage of the value of the land designated for future maintenance. Therefore, the amounts granted are based on \$6,670.00/ha. through cropped lands and \$2,500.00/ha. through bush. These values are multiplied by the hectares derived from the width granted for future maintenance and the applicable lengths.

For open ditches, the allowance provides for the loss of land due to the construction provided for in the report. The amounts granted are based on the value of the land, and the rate used was \$44,500.00/ha. When any buffer strip is incorporated and/or created, the allowance granted is for any land beyond a 1.8 meter width deemed to have always been part of the drain. For existing open ditches, the right-of-way to provide for the right to enter and restrictions imposed on those lands, is deemed to have already been granted.

## ASSESSMENT DEFINITIONS

In accordance with the Drainage Act, lands that make use of a drainage works are liable for assessment for part of the cost of constructing and maintaining the system. These liabilities are known as benefit, outlet liability and special benefit liability as set out under Sections 22, 23, 24 and 26 of the Act.

**BENEFIT** as defined in the Drainage Act means the advantages to any lands, roads, buildings or other structures from the construction, improvement, repair, or maintenance of a drainage works such as will result in a higher market value, increased crop production, improved appearance, better control of surface or sub-surface water, or any other advantages relating to the betterment of lands, roads, buildings, or other structures.

**OUTLET** liability is assessed to lands or roads that may make use of a drainage works as an outlet either directly or indirectly through the medium of any other drainage works or of a swale, ravine, creek, or watercourse.



## **ASSESSMENT DEFINITIONS (cont'd)**

In addition, a Public Utility or Road Authority shall be assessed for and pay all the increased cost to a drainage works due to the construction and operation of the Public Utility or Road Authority. This may be shown as either benefit or special assessment.

## **ASSESSMENT**

A modified "Todgham Method" was used to calculate the assessments shown on Schedule 'C'- Assessment for Construction. This entailed breaking down the costs of the drain into sections along its route.

The remainder is then separated into Benefit and Outlet costs. The Benefit cost is distributed to those properties receiving benefit as defined under "Assessment Definitions", with such properties usually being located along or close to the route of the drain. The Outlet Costs are distributed to all properties within the watershed area of that section on an adjusted basis. The areas are adjusted for location along that section, and relative run-off rates. Due to their different relative run-off rates forested lands have been assessed for outlet at lower rates than cleared lands. Also, roads and residential properties have been assessed for outlet at higher rates than cleared farmlands.

The actual cost of the work involving this report, is to be assessed on a pro-rata basis against the lands and roads liable for assessment for benefit and outlet as shown in detail on Schedule 'C' - Assessment for Construction.

## **SPECIAL ASSESSMENT**

If any additional work is required to the drainage works due to the existence of buried utilities such as gas pipelines, communications cables, etc. or if any of the utilities require relocation or repair then the extra costs incurred shall be borne by the utility involved in accordance with the provisions of Section 26 of the Drainage Act.

## **GRANTS**

In accordance with the provisions of Section 85 of the Drainage Act, a grant **may** be available for assessments against privately owned parcels of land which are used for agricultural purposes and eligible for the Farm Property Class Tax rate. Section 88 of the Drainage Act directs the Municipality to make application for this grant upon certification of completion of this drain. The Municipality will then deduct the grant from the assessments prior to collecting the final assessments.

It should be noted that the proposed enclosure is assessed separately and is not eligible for the agricultural grant.

## MAINTENANCE

Upon completion of construction all owners are hereby made aware of Sections 80 and 82 of the Drainage Act which forbid the obstruction of or damage or injury to a municipal drain.

After completion, the Merkley Drain shall be maintained by the Township of Howick at the expense of all upstream lands and roads assessed in Schedule 'D' - Assessment for Maintenance and in the same relative proportions until such time as the assessment is changed under the Drainage Act.

The remaining portions of the drain located in the Municipality of Morris-Turnberry shall be maintained in accordance with the grades and dimensions set out in the plans and specifications contained in the report dated July 15, 1970 by H.M. Gibson, P. Eng. and continue to be assessed as per that report.

Repairs or improvements to any road culvert or sub-surface road crossing required by the performance of this work and for future repair and/or replacement shall be the responsibility of the applicable Road Authority, entirely at their cost.

For future maintenance costs the farm culvert on the property of S. & K. Van Engen (Roll No. 900-030), shall be levied 50% to the affected owner and the remainder shall be pro-rated over the upstream outlet assessments.



BW:kj

Respectfully submitted,

SPRIET ASSOCIATES LONDON LIMITED

B. Widner, P.Eng.



## SCHEDULE 'A' - ALLOWANCES

**MERKLEY DRAIN****Township of Howick**

In accordance with Sections 29 and 30 of the Drainage Act, we determine the allowances payable to owners entitled thereto as follows:

<u>CONCESSION</u>	<u>LOT</u>	<u>ROLL NUMBER (Owner)</u>	<u>Section 29 Right-of-Way</u>	<u>Section 30 Damages</u>	<u>TOTALS</u>
<b>MAIN DRAIN - CLOSED PORTION (Sta. 0+000 - 0+243)</b>					
A	16	900-032-10 (J. Mulder)	\$	\$ 1,620.00	\$ 1,620.00
Total Allowances			\$	\$ 1,620.00	\$ 1,620.00
<b>TOTAL ALLOWANCES ON THE MAIN DRAIN - CLOSED PORTION (Sta. 0+000 - 0+243)</b>					<b>\$ 1,620.00</b>
<b>MAIN DRAIN - OPEN PORTION (Sta. 0+243 - 0+955)</b>					
A	14 & 15	900-030 (S. & K. Van Engen)	\$ 1,110.00	\$ 930.00	\$ 2,040.00
A	15	900-031 (G. Van Engen)	2,620.00	2,190.00	4,810.00
Total Allowances			\$ 3,730.00	\$ 3,120.00	\$ 6,850.00
<b>TOTAL ALLOWANCES ON THE MAIN DRAIN - OPEN PORTION (Sta. 0+243 - 0+955)</b>					<b>\$ 6,850.00</b>
<b>MAIN DRAIN - CLOSED PORTION (Sta. 0+955 - 1+606)</b>					
A	13	900-029 (B. & D. Merkley)	\$	\$ 4,300.00	\$ 4,300.00
Total Allowances			\$	\$ 4,300.00	\$ 4,300.00
<b>TOTAL ALLOWANCES ON THE MAIN DRAIN - CLOSED PORTION (Sta. 0+955 - 1+606)</b>					<b>\$ 4,300.00</b>
<b>MAIN DRAIN - OPEN PORTION (Sta. 1+606 - 2+124)</b>					
A	12	900-027 (I. Kaounis)	\$ 2,800.00	\$ 3,610.00	\$ 6,410.00
Total Allowances			\$ 2,800.00	\$ 3,610.00	\$ 6,410.00
<b>TOTAL ALLOWANCES ON THE MAIN DRAIN - OPEN PORTION (Sta. 1+606 - 2+124)</b>					<b>\$ 6,410.00</b>
<b>TOTAL ALLOWANCES ON THE MERKLEY DRAIN</b>					<b>\$ 19,180.00</b>

**MERKLEY DRAIN****Township of Howick**

We have made an estimate of the cost of the proposed work which is outlined in detail as follows:

**MAIN DRAIN - CLOSED PORTION (Sta. 0+000 - 0+243)**

Excavate material and construct wetland including shot rock (Sta. 0+000 - 0+035)	\$	9,000.00
Wetland Plantings as specified on the drawings	\$	1,000.00
6 meters of 900mm dia., H.D.P.E. plastic sewer pipe including rodent gate, shot rock protection around pipe and end of ditch (Approximately 6m <sup>3</sup> quarry stone req'd)		
Supply	\$	1,500.00
Installation	\$	1,300.00
Backfilling and regrading of existing open ditch using on-site materials from ditch banks and proposed wetland material (Sta. 0+000 - 0+243)	\$	10,000.00
Installation of the following concrete tile on crushed stone bedding		
243 meters of 825mm dia. concrete tile	\$	10,900.00
Supply of the above listed tile / pipe	\$	34,500.00
Supply and delivery of 19mm crushed stone bedding (125 Tonnes)	\$	2,500.00
Strip, stockpile and relevel topsoil from tile trench and adjacent working area (4m wide) specified on drawings (approx. 208m)	\$	1,500.00
Supply and install one 900mm x 1500mm on-line flattop catchbasins, including grates, berms, ditching,	\$	4,000.00
Exposing and locating existing tile drains and utilities	\$	500.00
Tile connections and contingencies	\$	3,800.00
Allowances under Section 30 of the Drainage Act	\$	1,620.00

**MAIN DRAIN - OPEN PORTION (Sta. 0+243 - 0+955)**

Supply and installation of quarry stone rip-rap protection on sideslopes, and around bend (Approximately 8m <sup>3</sup> quarry stone req'd)	\$	3,000.00
Clearing & grubbing of ditch bank (Approx. 692m)	\$	2,800.00
687 meters of open ditch cleanout	\$	3,400.00
Levelling excavated material where specified.	\$	1,400.00

**MERKLEY DRAIN**  
**Township of Howick**

**MAIN DRAIN - OPEN PORTION (Sta. 0+243 - 0+955) (cont'd)**

Sta. 0+757 - 0+769 (Roll No. 900-030)	
Supply & delivery of 12m - 1200mm dia, 2.8mm thick, 125mm x 25mm cor.	\$ 5,900.00
Installation of pipe including supply and installation of bedding and backfill materials and disposal of any unacceptable materials including couplers	\$ 5,900.00
Supply and installation of quarry stone riprap (Approx. 10m <sup>3</sup> Q.S. required)	\$ 1,500.00
Seeding of ditch banks and buffer strips (Approx. 1400m <sup>2</sup> )	\$ 900.00
Contingencies	\$ 1,200.00
Allowances under Sections 29 & 30 of the Drainage Act	\$ 6,850.00

**MAIN DRAIN - CLOSED PORTION (Sta. 0+955 - 1+606)**

6 meters of 750mm dia., H.D.P.E. plastic sewer pipe including rodent gate, quarry stone rip-rap protection around pipe and end of ditch (Approximately 6m <sup>3</sup> quarry stone req'd)	
Supply	\$ 1,500.00
Installation	\$ 1,300.00
Backfilling and Regrading of existing open ditch using on-site materials from ditch banks (Sta. 0+955 - 1+606)	\$ 24,000.00
Installation of the following concrete tile on crushed stone bedding	
651 meters of 675mm dia. concrete tile	\$ 26,000.00
Supply of the above listed tile / pipe	\$ 52,100.00
12 meters of 600mm dia. H.D.P.E. sewer pipe	
Supply	\$ 1,000.00
Installation under Laneway by open cut including disposal of existing lane culvert	\$ 4,900.00
Supply and delivery of 19mm crushed stone bedding (200 Tonnes)	\$ 4,000.00
Strip, stockpile and relevel topsoil from tile trench and adjacent working area (4m wide) specified on drawings (approx. 651m)	\$ 3,900.00
Supply and install one 900mm x 1200mm on-line ditch inlet catchbasins, including grates, berms, ditching, wyes, and any required prefab fittings	\$ 3,000.00
Exposing and locating existing tile drains and utilities	\$ 1,000.00
Tile connections and contingencies	\$ 6,000.00

**MERKLEY DRAIN  
Township of Howick**

**MAIN DRAIN - CLOSED PORTION (Sta. 0+961 - 1+606) (cont'd)**

Allowances under Section 30 of the Drainage Act	\$ 4,300.00
-------------------------------------------------	-------------

**MAIN DRAIN - OPEN PORTION (Sta. 1+606 - 2+124)**

Clearing & grubbing of ditch bank (Approx. 518m)	\$ 2,100.00
--------------------------------------------------	-------------

518 meters of open ditch cleanout	\$ 2,600.00
-----------------------------------	-------------

Levelling excavated material where specified.	\$ 1,000.00
-----------------------------------------------	-------------

Seeding of ditch banks and buffer strips (Approx. 1200m <sup>2</sup> )	\$ 600.00
------------------------------------------------------------------------	-----------

Tile connections and contingencies	\$ 300.00
------------------------------------	-----------

Allowances under Sections 29 & 30 of the Drainage Act	\$ 6,410.00
-------------------------------------------------------	-------------

**ADMINISTRATION**

Interest and Net Harmonized Sales Tax	\$ 7,290.00
---------------------------------------	-------------

Survey, Plan and Final Report	\$ 38,900.00
-------------------------------	--------------

Expenses	\$ 1,370.00
----------	-------------

Supervision and Final Inspection	\$ <u>9,460.00</u>
----------------------------------	--------------------

<b>TOTAL ESTIMATED COST</b>	<b>\$ <u><u>318,000.00</u></u></b>
-----------------------------	------------------------------------

SCHEDULE 'C' - ASSESSMENT FOR CONSTRUCTION

**MERKLEY DRAIN**

**Township of Howick**

Job No. 226038

May 15, 2026

\* = *Non-agricultural*

CON.	LOT	HECTARES AFFECTED	ROLL No. (OWNER)	BENEFIT	OUTLET	TOTAL
<b>MAIN DRAIN - CLOSED PORTION (Sta. 0+000 - 0+243)</b>						
<b>Township of Howick</b>						
A	16	4.85	900-032-10 (J. Mulder)	\$ 99,000.00	\$	\$ 99,000.00
TOTAL ASSESSMENT ON LANDS				\$ 99,000.00	\$	\$ 99,000.00
<b>TOTAL ASSESSMENT IN THE TOWNSHIP OF HOWICK</b>						<b>\$ 99,000.00</b>
<b>TOTAL ASSESSMENT ON THE MAIN DRAIN - CLOSED PORTION (Sta. 0+000 - 0+243)</b>						<b>\$ 99,000.00</b>
<b>MAIN DRAIN - OPEN PORTION (Sta. 0+243 - 0+955)</b>						
<b>Township of Howick</b>						
* A	10	0.10	900-024 (L. Cordick & B. Emptage)	\$	\$ 44.00	\$ 44.00
* A	11	0.80	900-026 (JFM Heidelberg Holdings Ltd)		265.00	265.00
A	11 & 12	18.90	900-025 (E. & S. Martin)		4,176.00	4,176.00
A	12	8.91	900-027 (I. Kaounis)		1,969.00	1,969.00
A	13	29.70	900-029 (B. & D. Merkley)		6,563.00	6,563.00
A	14 & 15	16.50	900-030 (S. & K. Van Engen)	11,575.00	2,205.00	13,780.00
* A	15	0.37	900-030-05 (D. & E. Weishar)		4.00	4.00
A	15	13.80	900-031 (G. Van Engen)	7,670.00	570.00	8,240.00
TOTAL ASSESSMENT ON LANDS				\$ 19,245.00	\$ 15,796.00	\$ 35,041.00
Howick Turnberry Road	0.10		Huron County	\$	\$ 77.00	\$ 77.00
County Road 12	2.40		Huron County		1,855.00	1,855.00
Salem Road	0.80		Township of Howick	3,080.00	265.00	3,345.00
TOTAL ASSESSMENT ON ROADS				\$ 3,080.00	\$ 2,197.00	\$ 5,277.00
<b>TOTAL ASSESSMENT IN THE TOWNSHIP OF HOWICK</b>						<b>\$ 40,318.00</b>

SCHEDULE 'C' - ASSESSMENT FOR CONSTRUCTION (cont'd)

**MERKLEY DRAIN  
Township of Howick**

CON.	LOT	HECTARES AFFECTED	ROLL No. (OWNER)	BENEFIT	OUTLET	TOTAL
<b>MAIN DRAIN - OPEN PORTION (Sta. 0+243 - 0+955) (cont'd)</b>						
<b>Municipality of Morris-Turnberry</b>						
C	10	3.00	16-013 (A. & M. Martin)	\$	\$ 663.00	\$ 663.00
C	11	7.90	16-015 (J. & T. Fitch)		1,746.00	1,746.00
C	12	3.30	16-016 (J. Simmons)		729.00	729.00
TOTAL ASSESSMENT ON LANDS				\$	\$ 3,138.00	\$ 3,138.00
Howick Turnberry Road		0.70	Huron County	\$	\$ 544.00	\$ 544.00
TOTAL ASSESSMENT ON ROADS				\$	\$ 544.00	\$ 544.00
<b>TOTAL ASSESSMENT IN THE MUNICIPALITY OF MORRIS-TURNBERRY</b>						<b>\$ 3,682.00</b>
<b>TOTAL ASSESSMENT ON THE MAIN DRAIN - OPEN PORTION (Sta. 0+243 - 0+955)</b>						<b>\$ 44,000.00</b>
<b>MAIN DRAIN - CLOSED PORTION (Sta. 0+955 - 1+606)</b>						
<b>Township of Howick</b>						
A	13	29.70	900-029 (B. & D. Merkley)	\$ 157,000.00	\$	\$ 157,000.00
TOTAL ASSESSMENT ON LANDS				\$ 157,000.00	\$	\$ 157,000.00
<b>TOTAL ASSESSMENT IN THE TOWNSHIP OF HOWICK</b>						<b>\$ 157,000.00</b>
<b>TOTAL ASSESSMENT ON THE MAIN DRAIN - CLOSED PORTION (Sta. 0+955 - 1+606)</b>						<b>\$ 157,000.00</b>

SCHEDULE 'C' - ASSESSMENT FOR CONSTRUCTION (cont'd)

**MERKLEY DRAIN  
Township of Howick**

CON.	LOT	HECTARES AFFECTED	ROLL No. (OWNER)	BENEFIT	OUTLET	TOTAL		
<b>MAIN DRAIN - OPEN PORTION (Sta. 1+606 - 2+124)</b>								
<b>Howick Township</b>								
* A	10	0.10	900-024 (L. Cordick & B. Emptage)	\$	\$ 49.00	\$ 49.00		
* A	11	0.80	900-026 (JFM Heidelberg Holdings Ltd)		196.00	196.00		
A	11 & 12	18.90	900-025 (E. & S. Martin)		2,328.00	2,328.00		
A	12	8.91	900-027 (I. Kaounis)	8,100.00	1,096.00	9,196.00		
TOTAL ASSESSMENT ON LANDS				\$	8,100.00	\$ 3,669.00	\$ 11,769.00	
Howick Turnberry Road				0.10	Huron County	\$	\$ 86.00	\$ 86.00
County Road 12				2.40	Huron County		2,058.00	2,058.00
TOTAL ASSESSMENT ON ROADS				\$		\$ 2,144.00	\$ 2,144.00	
<b>TOTAL ASSESSMENT IN HOWICK TOWNSHIP</b>						<b>\$ 13,913.00</b>		
<b>Municipality of Morris-Turnberry</b>								
C	10	3.00	16-013 (A. & M. Martin)	\$	\$ 736.00	\$ 736.00		
C	11	7.90	16-015 (J. & T. Fitch)		1,938.00	1,938.00		
C	12	3.30	16-016 (J. Simmons)		809.00	809.00		
TOTAL ASSESSMENT ON LANDS				\$	\$ 3,483.00	\$ 3,483.00		
Howick Turnberry Road				0.70	Huron County	\$	\$ 604.00	\$ 604.00
TOTAL ASSESSMENT ON ROADS				\$	\$ 604.00	\$ 604.00		
<b>TOTAL ASSESSMENT IN THE MUNICIPALITY OF MORRIS-TURNBERRY</b>						<b>\$ 4,087.00</b>		
<b>TOTAL ASSESSMENT ON THE MAIN DRAIN - OPEN PORTION (Sta. 1+606 - 2+124)</b>						<b>\$ 18,000.00</b>		
<b>TOTAL ASSESSMENT ON THE MERKLEY DRAIN</b>						<b>\$ 318,000.00</b>		

SCHEDULE 'D' - ASSESSMENT FOR MAINTENANCE

**MERKLEY DRAIN**

**Township of Howick**

Job No. 226038

May 15, 2026

CON.	LOT	HECTARES AFFECTED	ROLL No. (OWNER)	PERCENTAGE OF MAINTENANCE COST
<b>MAIN DRAIN - CLOSED PORTION (Sta. 0+000 - 0+243)</b>				
<b>Howick Township</b>				
A	10	0.10	900-024 (L. Cordick & B. Emptage)	0.1 %
A	11	0.80	900-026 (JFM Heidelberg Holdings Ltd)	0.9
A	11 & 12	18.90	900-025 (E. & S. Martin)	11.0
A	12	8.91	900-027 (I. Kaounis)	5.2
A	13	29.70	900-029 (B. & D. Merkley)	17.2
A	14 & 15	16.50	900-030 (S. & K. Van Engen)	8.5
A	15	0.37	900-030-05 (D. & E. Weishar)	0.2
A	15	13.80	900-031 (G. Van Engen)	6.0
A	16	4.85	900-032-10 (J. Mulder)	34.7
				=====
TOTAL ASSESSMENT ON LANDS				83.8 %
				=====
Howick Turnberry Road		0.10	Huron County	0.2 %
County Road 12		2.40	Huron County	4.8
Salem Road		0.80	Township of Howick	1.4
				=====
TOTAL ASSESSMENT ON ROADS				6.4 %
				=====
<b>TOTAL ASSESSMENT FOR MAINTENANCE IN HOWICK TOWNSHIP</b>				<b><u>90.2 %</u></b>
<b>Municipality of Morris-Turnberry</b>				
C	10	3.00	16-013 (A. & M. Martin)	1.7 %
C	11	7.90	16-015 (J. & T. Fitch)	4.6
C	12	3.30	16-016 (J. Simmons)	1.9
				=====
TOTAL ASSESSMENT ON LANDS				8.2 %
				=====
Howick Turnberry Road		0.70	Huron County	1.6 %
				=====
TOTAL ASSESSMENT ON ROADS				1.6 %
				=====
<b>TOTAL ASSESSMENT FOR MAINTENANCE IN THE MUNICIPALITY OF MORRIS-TURNBERRY</b>				<b><u>9.8 %</u></b>
				=====
<b>TOTAL ASSESSMENT FOR MAINTENANCE ON MAIN DRAIN - CLOSED PORTION (Sta. 0+000 - 0+243)</b>				<b><u>100.0 %</u></b>

## SCHEDULE 'D' - ASSESSMENT FOR MAINTENANCE (cont'd)

**MERKLEY DRAIN  
Township of Howick**

CON.	LOT	HECTARES AFFECTED	ROLL No. (OWNER)	PERCENTAGE OF MAINTENANCE COST
<b>MAIN DRAIN - OPEN PORTION (Sta. 0+243 - 0+955)</b>				
<b>Howick Township</b>				
A	10	0.10	900-024 (L. Cordick & B. Emptage)	0.1 %
A	11	0.80	900-026 (JFM Heidelberg Holdings Ltd)	1.1
A	11 & 12	18.90	900-025 (E. & S. Martin)	12.7
A	12	8.91	900-027 (I. Kaounis)	6.0
A	13	29.70	900-029 (B. & D. Merkley)	19.9
A	14 & 15	16.50	900-030 (S. & K. Van Engen)	16.2
A	15	0.37	900-030-05 (D. & E. Weishar)	0.1
A	15	13.80	900-031 (G. Van Engen)	25.1
				=====
TOTAL ASSESSMENT ON LANDS				81.2 %
				=====
Howick Turnberry Road		0.10	Huron County	0.2 %
County Road 12		2.40	Huron County	5.5
Salem Road		0.80	Township of Howick	1.9
				=====
TOTAL ASSESSMENT ON ROADS				7.6 %
				=====
<b>TOTAL ASSESSMENT FOR MAINTENANCE IN HOWICK TOWNSHIP</b>				<b><u>88.8 %</u></b>
<b>Municipality of Morris-Turnberry</b>				
C	10	3.00	16-013 (A. & M. Martin)	2.0 %
C	11	7.90	16-015 (J. & T. Fitch)	5.3
C	12	3.30	16-016 (J. Simmons)	2.2
				=====
TOTAL ASSESSMENT ON LANDS				9.5 %
				=====
Howick Turnberry Road		0.70	Huron County	1.7 %
				=====
TOTAL ASSESSMENT ON ROADS				1.7 %
				=====
<b>TOTAL ASSESSMENT FOR MAINTENANCE IN THE MUNICIPALITY OF MORRIS-TURNBERRY</b>				<b><u>11.2 %</u></b>
<b>TOTAL ASSESSMENT FOR MAINTENANCE ON MAIN DRAIN - OPEN PORTION (Sta. 0+243 - 0+955)</b>				<b><u>100.0 %</u></b>

SCHEDULE 'D' - ASSESSMENT FOR MAINTENANCE (cont'd)

**MERKLEY DRAIN  
Township of Howick**

CON.	LOT	HECTARES AFFECTED	ROLL No. (OWNER)	PERCENTAGE OF MAINTENANCE COST
<b>MAIN DRAIN - CLOSED PORTION (Sta. 0+955 - 1+606)</b>				
<b>Howick Township</b>				
A	10	0.10	900-024 (L. Cordick & B. Emptage)	0.2 %
A	11	0.80	900-026 (JFM Heidelberg Holdings Ltd)	13.7
A	11 & 12	18.90	900-025 (E. & S. Martin)	14.7
A	12	8.91	900-027 (I. Kaounis)	6.9
A	13	29.70	900-029 (B. & D. Merkley)	44.9
				=====
TOTAL ASSESSMENT ON LANDS				80.4 %
				=====
Howick Turnberry Road		0.10	Huron County	0.3 %
County Road 12		2.40	Huron County	6.5
				=====
TOTAL ASSESSMENT ON ROADS				6.8 %
				=====
<b>TOTAL ASSESSMENT FOR MAINTENANCE IN TOWNSHIP OF HOWICK</b>				<b><u>87.2 %</u></b>
<b>Municipality of Morris-Turnberry</b>				
C	10	3.00	16-013 (A. & M. Martin)	2.3 %
C	11	7.90	16-015 (J. & T. Fitch)	6.1
C	12	3.30	16-016 (J. Simmons)	2.6
				=====
TOTAL ASSESSMENT ON LANDS				11.0 %
				=====
Howick Turnberry Road		0.70	Huron County	1.8 %
				=====
TOTAL ASSESSMENT ON ROADS				1.8 %
				=====
<b>TOTAL ASSESSMENT FOR MAINTENANCE IN THE MUNICIPALITY OF MORRIS-TURNBERRY</b>				<b><u>12.8 %</u></b>
<b>TOTAL ASSESSMENT FOR MAINTENANCE ON MAIN DRAIN - CLOSED PORTION (Sta. 0+955 - 1+606)</b>				<b><u>100.0 %</u></b>

## SCHEDULE 'D' - ASSESSMENT FOR MAINTENANCE (cont'd)

**MERKLEY DRAIN  
Township of Howick**

CON.	LOT	HECTARES AFFECTED	ROLL No. (OWNER)	PERCENTAGE OF MAINTENANCE COST
<b>MAIN DRAIN - OPEN PORTION (Sta. 1+606 - 2+124)</b>				
<b>Howick Township</b>				
A	10	0.10	900-024 (L. Cordick & B. Emptage)	0.2 %
A	11	0.80	900-026 (JFM Heidelberg Holdings Ltd)	1.3
A	11 & 12	18.90	900-025 (E. & S. Martin)	15.7
A	12	8.91	900-027 (I. Kaounis)	40.7
				=====
TOTAL ASSESSMENT ON LANDS				57.9 %
				=====
Howick Turnberry Road		0.10	Huron County	0.6 %
County Road 12		2.40	Huron County	13.9
				=====
TOTAL ASSESSMENT ON ROADS				14.5 %
				=====
<b>TOTAL ASSESSMENT FOR MAINTENANCE IN HOWICK TOWNSHIP</b>				<b><u>72.4 %</u></b>
<b>Municipality of Morris-Turnberry</b>				
C	10	3.00	16-013 (A. & M. Martin)	5.0 %
C	11	7.90	16-015 (J. & T. Fitch)	13.1
C	12	3.30	16-016 (J. Simmons)	5.5
				=====
TOTAL ASSESSMENT ON LANDS				23.6 %
				=====
Howick Turnberry Road		0.70	Huron County	4.0 %
				=====
TOTAL ASSESSMENT ON ROADS				4.0 %
				=====
<b>TOTAL ASSESSMENT FOR MAINTENANCE IN THE MUNICIPALITY OF MORRIS-TURNBERRY</b>				<b><u>27.6 %</u></b>
<b>TOTAL ASSESSMENT FOR MAINTENANCE ON MAIN DRAIN - OPEN PORTION (Sta. 1+606 - 2+124)</b>				<b><u>100.0 %</u></b>

SCHEDULE OF NET ASSESSMENT

**MERKLEY DRAIN**

**Township of Howick**

(FOR INFORMATION PURPOSES ONLY)

Job No. 226038

May 15, 2026

\* = *Non-agricultural*

ROLL NUMBER (OWNER)	TOTAL ASSESSMENT	GRANT	ALLOWANCES	APPROX. NET
<b>Township of Howick</b>				
* 900-024 (L. Cordick & B. Emptage)	\$ 93.00	\$	\$	93.00
* 900-026 (JFM Heidelberg Holdings Ltd)	461.00			461.00
900-025 (E. & S. Martin)	6,504.00	2,168.00		4,336.00
900-027 (I. Kaounis)	11,165.00	3,722.00	6,410.00	1,033.00
900-029 (B. & D. Merkley)	6,563.00	2,188.00		4,375.00
* <b>**Non-Grantable**</b>	157,000.00		4,300.00	152,700.00
900-030 (S. & K. Van Engen)	13,780.00	4,593.00	2,040.00	7,147.00
* 900-030-05 (D. & E. Weishar)	4.00			4.00
900-031 (G. Van Engen)	8,240.00	2,747.00	4,810.00	683.00
* 900-032-10 (J. Mulder)	99,000.00		1,620.00	97,380.00
* Howick Turnberry Road	\$ 163.00	\$	\$	163.00
* County Road 12	3,913.00			3,913.00
* Salem Road	3,345.00			3,345.00
<b>Municipality of Morris-Turnberry</b>				
16-013 (A. & M. Martin)	\$ 1,399.00	\$ 466.00	\$	933.00
16-015 (J. & T. Fitch)	3,684.00	1,228.00		2,456.00
16-016 (J. Simmons)	1,538.00	513.00		1,025.00
* Howick Turnberry Road	1,148.00	\$	\$	1,148.00
<b>TOTALS</b>	<b>\$ 318,000.00</b>	<b>\$ 17,625.00</b>	<b>\$ 19,180.00</b>	<b>\$ 281,195.00</b>

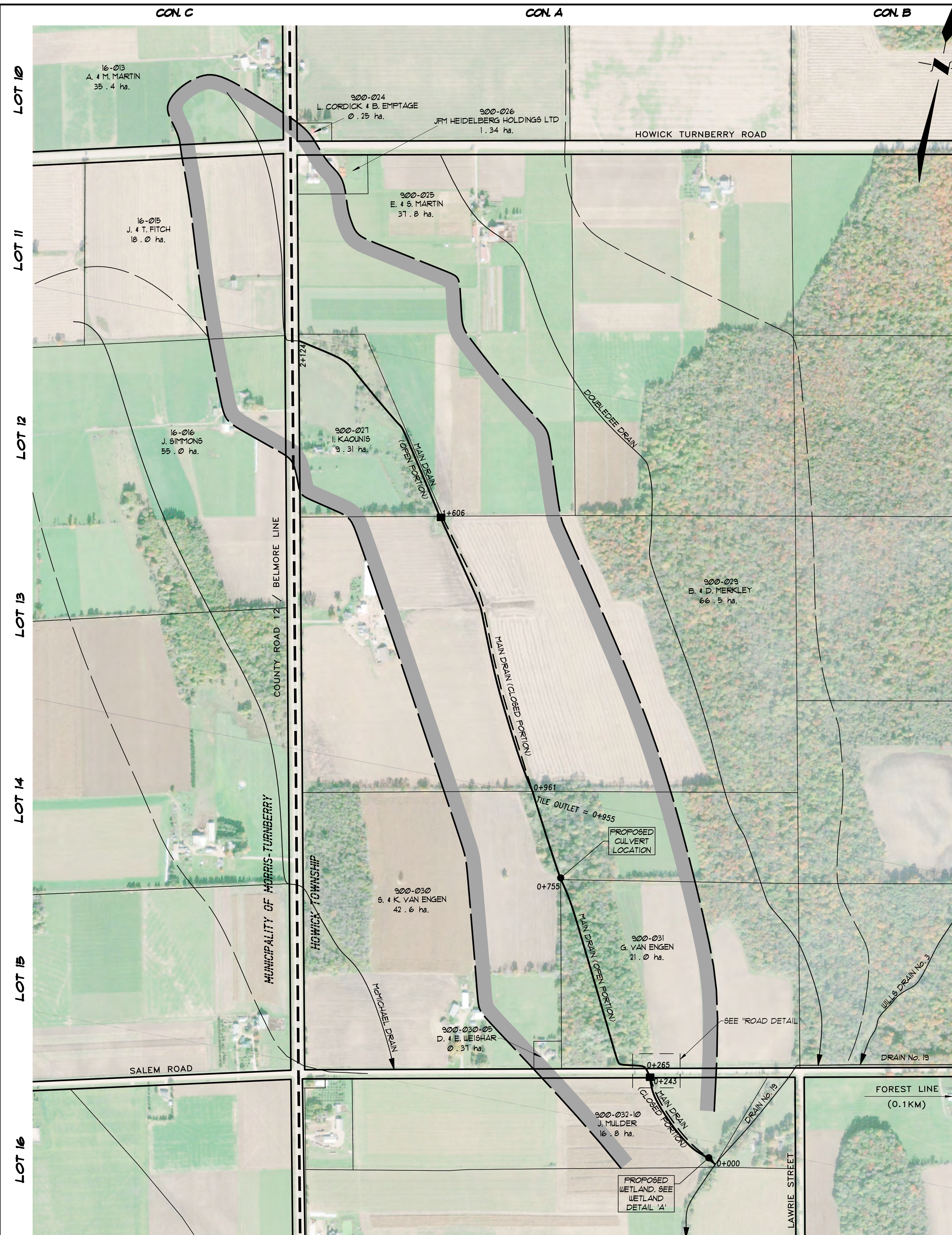

PLAN SCALE 1:5,000

**GENERAL NOTES**

- 1/ OUR SPECIFICATIONS FOR THE CONSTRUCTION OF MUNICIPAL DRAINAGE WORKS, DATED JANUARY 2020 APPLY TO THIS PROJECT.
- 2/ THE WORKING WIDTH AVAILABLE TO THE CONTRACTOR TO CONSTRUCT THE NEW DRAINS SHALL CONSIST OF THOSE LANDS IMMEDIATELY ADJACENT TO THE DRAIN AND CONNECTIONS AND SHALL NOT EXCEED THE FOLLOWING AVERAGE WIDTHS:  
 - 15 meters TOTAL (REMOVE ONLY TREES ALONG BANK AND THOSE ABSOLUTELY NECESSARY TO COMPLETE CONSTRUCTION)  
 - 20 meters TOTAL (REMOVE ONLY TREES ALONG BANK AND THOSE ABSOLUTELY NECESSARY TO COMPLETE CONSTRUCTION)  
 CLOSED PORTIONS  
 THE WORKING WIDTH FOR PURPOSES OF FUTURE MAINTENANCE SHALL BE THE SAME AS ABOVE EXCEPT FOR CLOSED PORTIONS (NOT THROUGH BUSH) SHALL BE 10m.
- 3/ ALL OWNERS ALONG THE COURSE OF THE DRAIN SHALL MAKE AN ACCESS ROUTE FROM THE NEAREST ROAD TO THE DRAIN LOCATION AVAILABLE TO THE CONTRACTOR THE AVERAGE WIDTH OF THIS ROUTE SHALL NOT EXCEED 8 METERS. THE ACCESS ROUTE SHALL ALSO APPLY FOR FUTURE MAINTENANCE PURPOSES.
- 4/ a) ALL UTILITIES TO BE LOCATED AND EXPOSED PRIOR TO CONSTRUCTION SO THAT THE NEW TILE GRADES CAN BE CONFIRMED. IF THERE IS A CONFLICT IN ELEVATION BETWEEN THE PROPOSED DRAIN AND THE UTILITY, THE ENGINEER IS TO BE NOTIFIED IMMEDIATELY.  
 b) CONTRACTOR TO NOTIFY ALL UTILITIES 72 HOURS PRIOR TO HIS SCHEDULED TIME FOR STARTING THE ABOVE WORK.  
 c) THE COST FOR THIS WORK SHALL BE INCLUDED IN THE ITEM TO THE EXTENT OF WORK AND NO EXTRA PAYMENT SHALL BE MADE TO THE CONTRACTOR, EXCEPT IF ROAD RESTORATION IS REQUIRED.
- 5/ ALL TREES, SCRUB, BRUSH, ETC. TO BE CLEARED AND GRUBBED IN ACCORDANCE WITH "SECTION B.3 AND C.4" SPECIFICATIONS.
- 6/ RIP-RAP TO BE SUPPLIED AND INSTALLED IN ACCORDANCE WITH "SECTION A.12" IN THE SPECIFICATIONS.
- 7/ CONTRACTOR TO ARRANGE A PRE-CONSTRUCTION MEETING WITH THE ENGINEER, DRAINAGE SUPERINTENDENT, AND THE AFFECTED OWNERS. ALL PARTIES SHALL RECEIVE 48 HOURS NOTICE TO THE MEETING.

**CLOSED PORTIONS**

- 8/ ALL CONCRETE TILE, PLASTIC TILE, HDPE PIPE AND HDPE SEWER PIPE TO CONFORM TO "SECTION C.1" IN THE SPECIFICATIONS.  
 a) CONCRETE TILE SHALL BE HEAVY DUTY UNLESS SPECIFIED 2000 D OR 2400 D ON PROFILE.  
 b) SEWER PIPE TO BE H.D.P.E. PLASTIC 320 KPA (BELL & SPIGOT WITH RUBBER GASKETS, CONFORMING TO C.S.A. 1016-08), PVC ULTRA RIB OR PVC SDR 35.
- 9/ ALL CATCHBASINS SHALL BE SUPPLIED AND INSTALLED IN ACCORDANCE WITH "SECTION C.16" IN THE SPECIFICATIONS.
- 10/ EXACT LOCATION OF NEW DRAIN TO BE DETERMINED AT TIME OF CONSTRUCTION BY DRAINAGE SUPERINTENDENT OR ENGINEER.
- 11/ a) INSTALLATION OF TILE AND TRENCH WIDTHS SHALL BE IN ACCORDANCE WITH "SECTION C - TILE DRAIN" IN THE SPECIFICATIONS.  
 b) ALL CONCRETE TILE AND TILE-PIPE JOINTS TO BE WRAPPED WITH GEOTEXTILE IN ACCORDANCE WITH "SECTION C.8" IN THE SPECIFICATIONS.  
 c) NO CONSTRUCTION EQUIPMENT OR FARM MACHINERY SHALL CROSS OVER THE MOUNDED BACKFILLED TILE TRENCHES UNTIL SUFFICIENT SETTLEMENT HAS OCCURRED.  
 d) STRIP AND STOCKPILE TOPSOIL FROM CONSTRUCTION AREA (4 metre width) EXCEPT LANEWAYS & ROADS. EXCESS SPOIL TO BE LEVELLED AND TOPSOIL RELEVELLED OVER SPOIL, MOUNDED TRENCH AND REMAINING CONSTRUCTION AREA.

**OPEN PORTIONS**

- 13/ EXISTING DITCH BOTTOM ONLY TO BE CLEANED OUT IN ACCORDANCE WITH SPECIFICATIONS UNLESS OTHERWISE NOTED ON PROFILES AND IN SECTIONS.
- 14/ WORK TO BE COMPLETED FROM AND EXCAVATED MATERIAL TO BE DEPOSITED AND LEVELLED ON THE FOLLOWING SIDES OF THE DITCH IN ACCORDANCE WITH "SECTION B.5" IN THE SPECIFICATIONS:  
 STA. 0+243 TO STA. 0+395 - WEST SIDE AND LEVELLED  
 STA. 1+606 TO STA. 2+124 - WEST SIDE AND LEVELLED
- 15/ A 3 METER WIDE BUFFER STRIP OF NEW & EXISTING VEGETATION BETWEEN THE TOP OF THE BANK AND THE CULTIVATED LANDS ON BOTH SIDES OF THE DITCH SHALL BE MAINTAINED AS PART OF THE OPEN PORTION OF THE DRAIN.
- 16/ NEULY EXPOSED DITCH BANKS ARE TO BE HAND SEEDDED UPON COMPLETION OF CONSTRUCTION IN ACCORDANCE WITH "SECTION B.11" IN THE SPECIFICATIONS

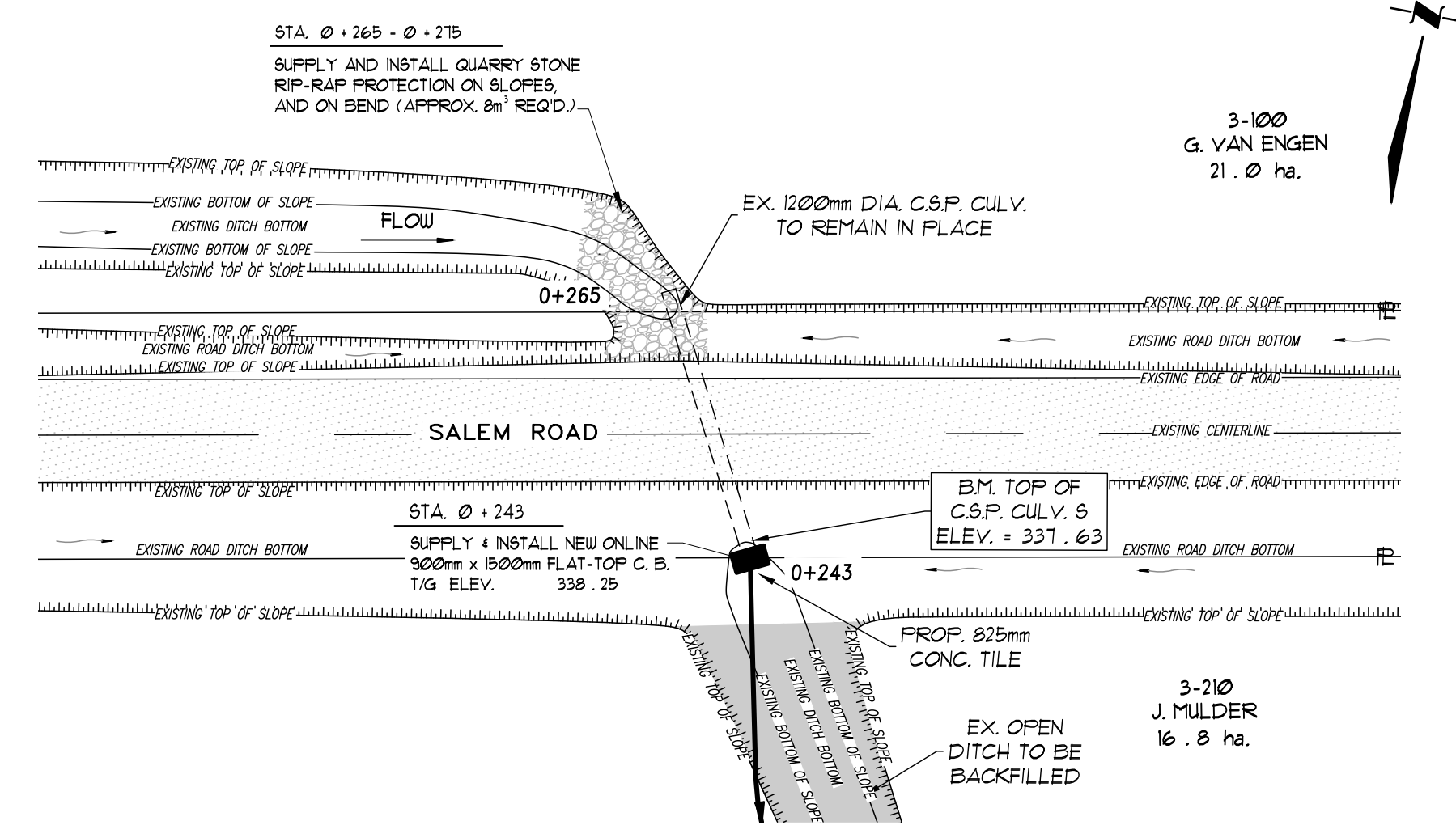

ROAD DETAIL SCALE 1:500

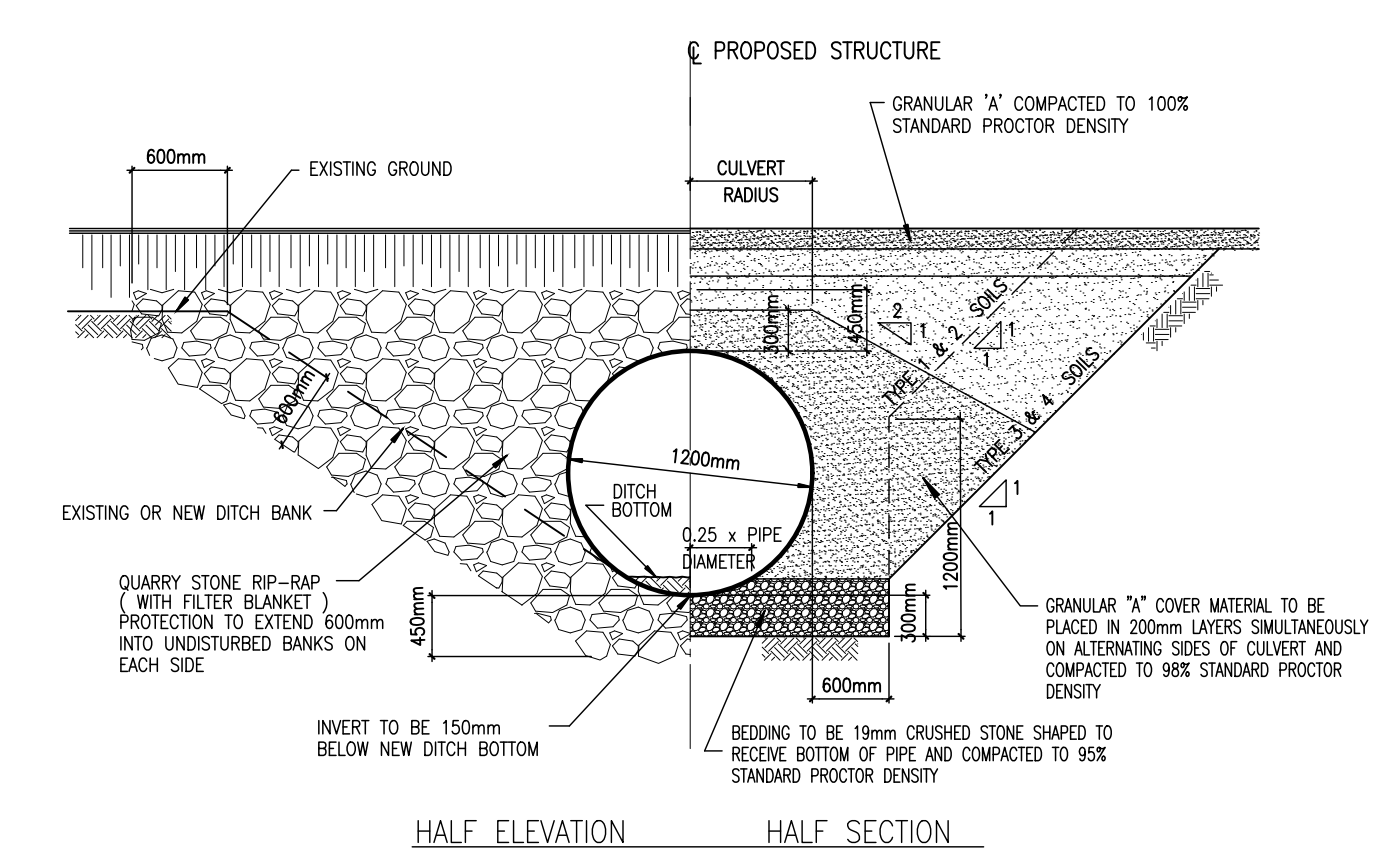

HALF ELEVATION HALF SECTION

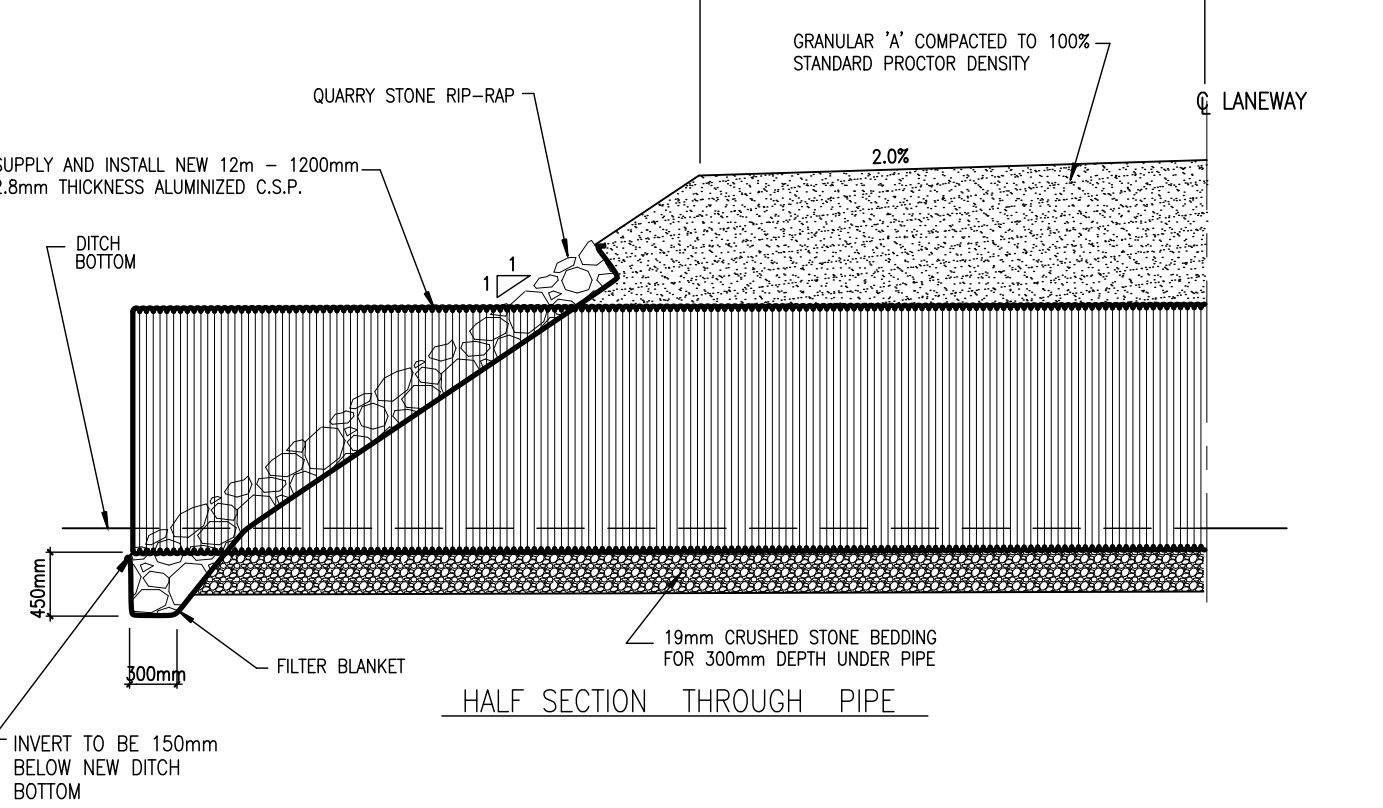

VAN ENGEN CULVERT DETAILS

N. T. S.

**PLAN LEGEND**

[Symbol]	LIMIT OF WATERSHED AREA
[Symbol]	PROPOSED DRAINAGE WORKS
[Symbol]	EXTERIOR OR INTERIOR WATERSHED
[Symbol]	TO BE ENCLOSED
[Symbol]	EXIST. MUNICIPAL DRAIN
[Symbol]	PRIVATE TILE OR SURFACE WATER RUN
[Symbol]	EXIST. WATERCOURSE OR PRIVATE DITCH
[Symbol]	OWNERS NAME
[Symbol]	HECTARES OWNED
[Symbol]	CONIFEROUS, DECIDUOUS TREES

**MERKLEY DRAIN**

Howick TOWNSHIP

Drainage Superintendent: <b>SCOTT RICHARDSON</b> 519 - 335 - 3208	No. _____	REVISIONS	DATE
Drawn By: <b>RL</b>	Field Book: <b>GFS</b>	JOB No.: <b>226038</b>	Drawing No.: <b>1 of 2</b>
Date: <b>MAY, 15, 2026</b>	ASSESSMENT ROLL NUMBER: <b>100213628</b>	OWNERS NAME: <b>J. MULDER</b> HECTARES OWNED: <b>16.8</b>	

**PLAN, DETAILS, & NOTES**

**SPRIET ASSOCIATES**  
LONDON LIMITED  
CONSULTING ENGINEERS  
155 YORK STREET - LONDON (519) 672-4100 - NEA 1A8

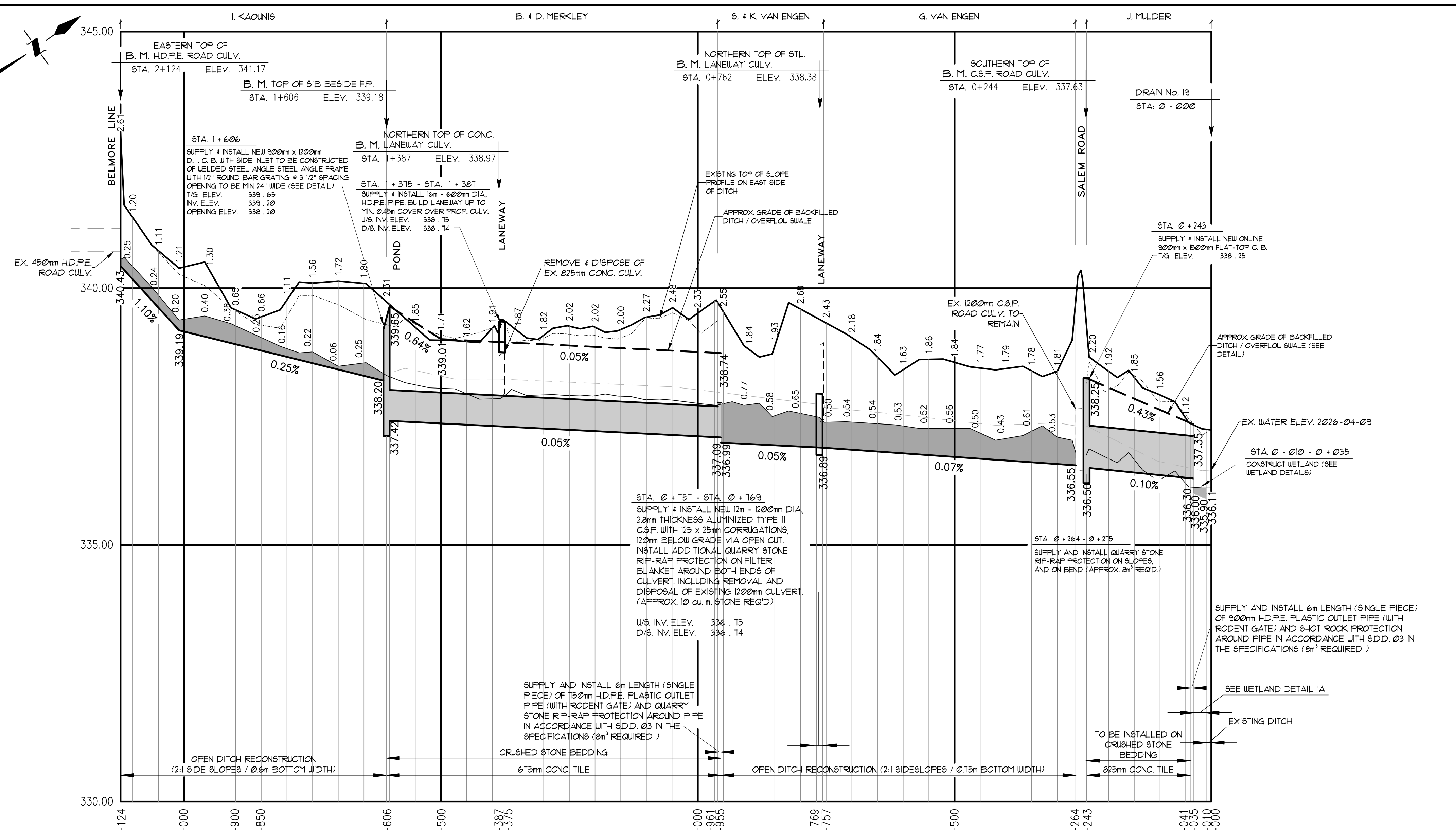
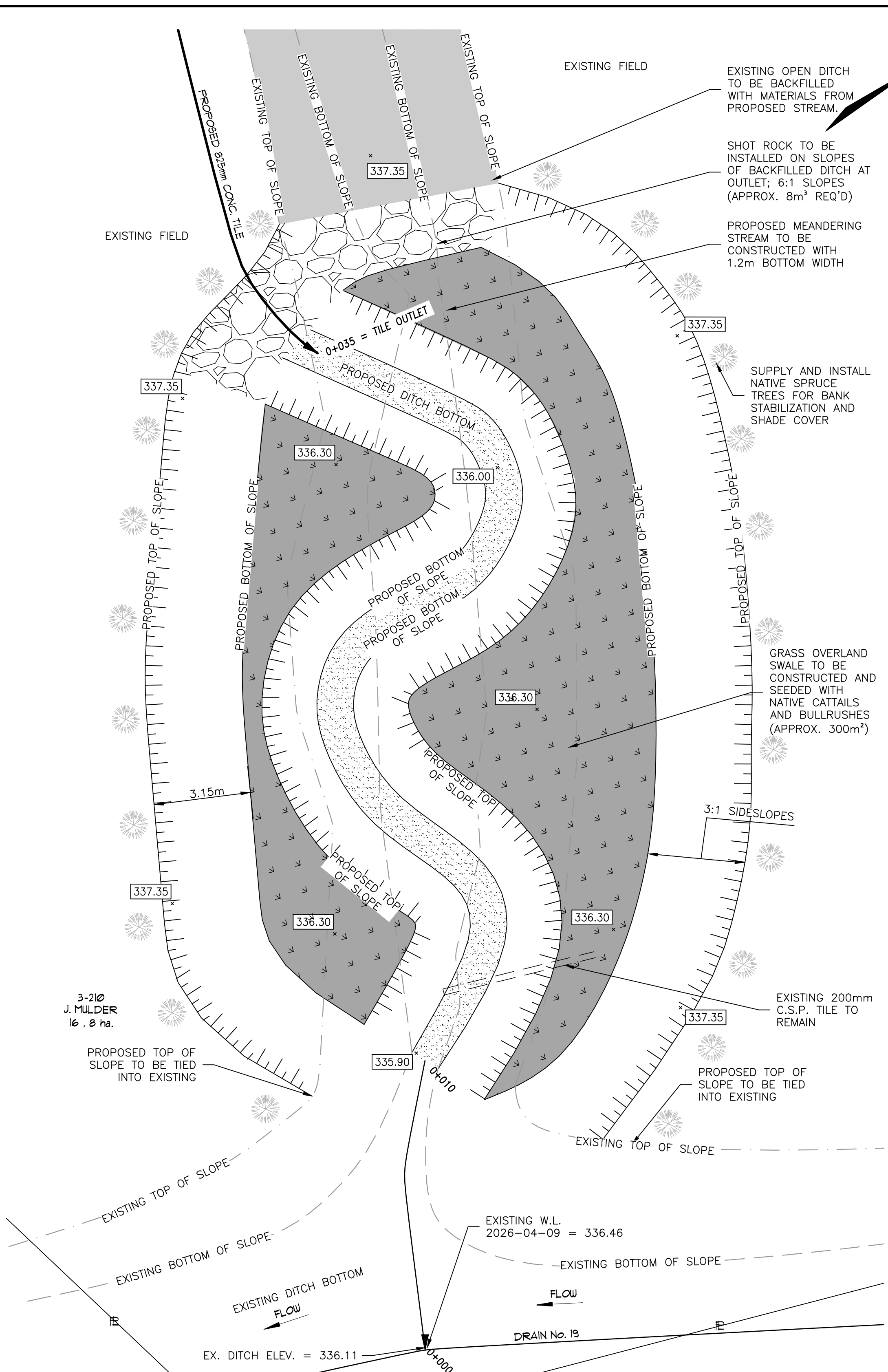

**MAIN DRAIN**  
SCALE: HOR. 1:5,000  
VERT. 1:50

**WETLAND DETAIL 'A'** SCALE: 1:100

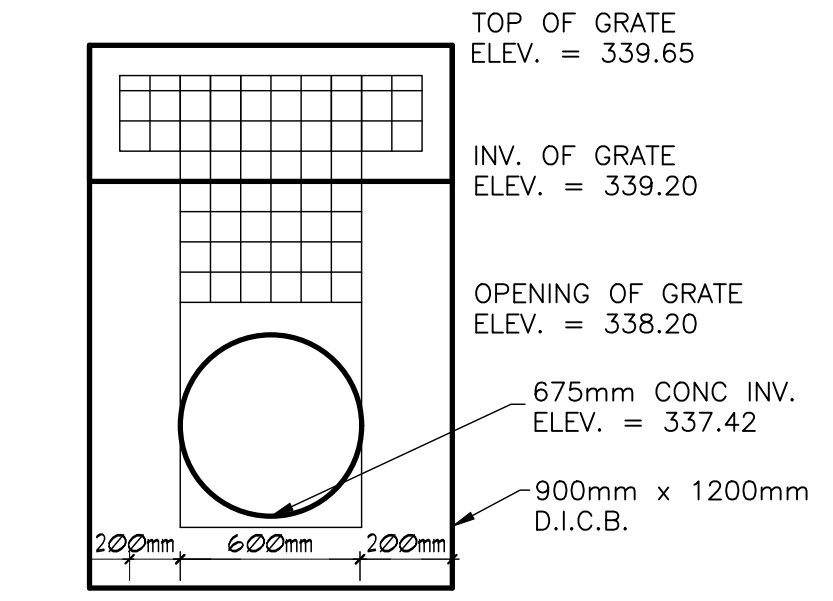

**SIDE INLET CATCHBASIN (STA. 1 + 606)**  
SCALE: N.T.S.

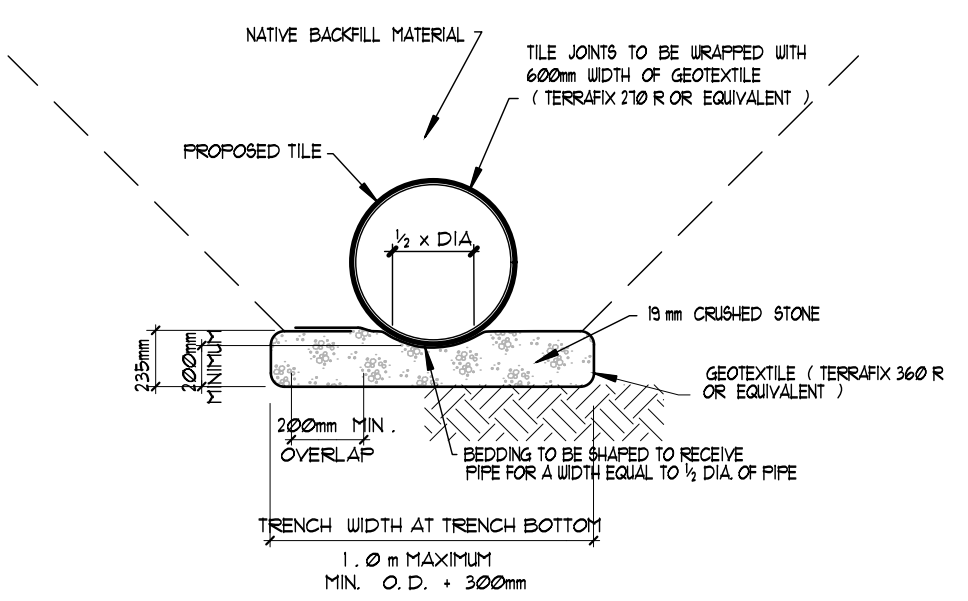

**CRUSHED STONE BEDDING DETAIL  
CONCRETE FIELD TILE**  
SCALE: N.T.S.

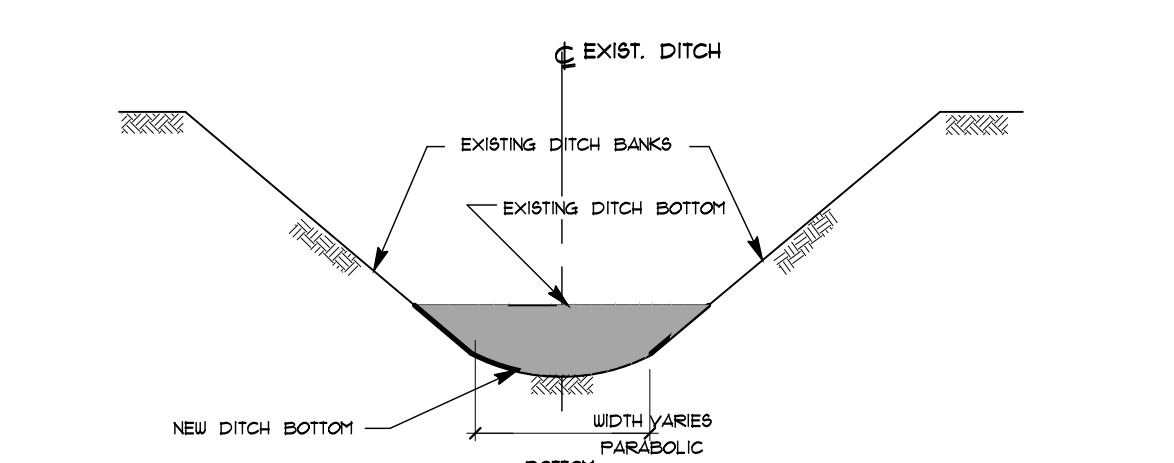

**TYPICAL DITCH BOTTOM CLEANOUT**  
SCALE: N.T.S.

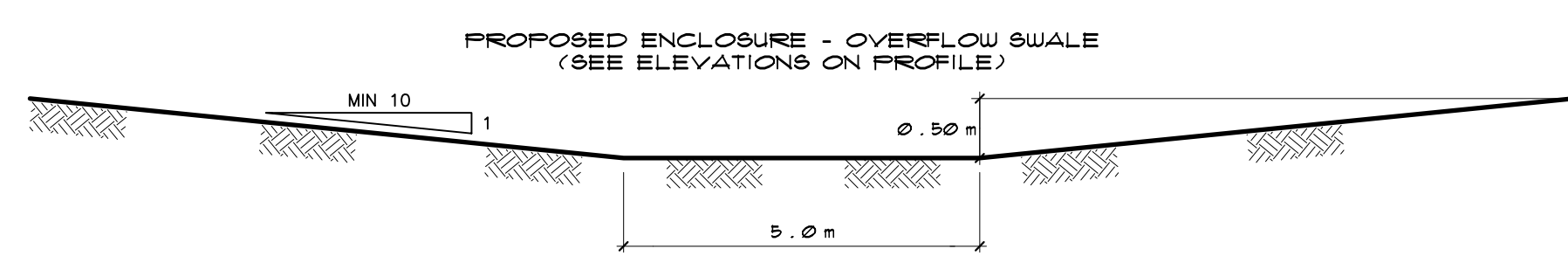

**TYPICAL CROSS SECTION OF OVERFLOW  
SWALE CONSTRUCTED OVER BACKFILLED CHANNEL**  
SCALE: N.T.S.

**MERKLEY DRAIN**  
Howick TOWNSHIP

Drainage Superintendent:  
**SCOTT RICHARDSON**  
519 - 335 - 3208

Drawn By: **RL** Field Book: **GFS** JOB No.: **226038** Drawing No.: **2 of 2**

Date: **MAY 15, 2026**

**PROFILE, & DETAILS**

**SPRIET ASSOCIATES**  
LONDON CONSULTING ENGINEERS LIMITED  
155 YORK STREET - LONDON (519) 672-4100 - NEA 1A8

PROVINCE OF ONTARIO  
LICENSED PROFESSIONAL ENGINEER  
**B. E. WIJNER**  
100213828

**By-law for Municipalities Not Within a Regional  
Municipality, the County of Oxford or The  
District Municipality of Muskoka – Form 5**

*Drainage Act, R.S.O. 1990, c. D.17, subs. 45(1)*

Drainage By-law Number 43-2026

A by-law to provide for a drainage works in the Township of Howick  
in the County of Huron.

Whereas the council of the Township of Howick has procured a  
report under section 78 of the *Drainage Act* for the improvement  
of the Merkley Municipal Drain drain;

And whereas the report dated 2026/05/15 has been authored by Spriet Associates Engineers & Architects  
and the attached report forms part of this by-law;

And whereas the estimated total cost of the drainage work is \$318,000.00 ;

And whereas \$310,231.00 is the amount to be contributed by the Township  
of Howick for the drainage works;

And whereas (Complete this clause only if other municipalities are being assessed a share of the cost of the project.);

\$7,769.00 is being assessed in the Municipality of Morris-Turnberry  
\_\_\_\_\_ is being assessed in the \_\_\_\_\_ of \_\_\_\_\_  
\_\_\_\_\_ is being assessed in the \_\_\_\_\_ of \_\_\_\_\_  
\_\_\_\_\_ is being assessed in the \_\_\_\_\_ of \_\_\_\_\_

And whereas the council is of the opinion that drainage of the area is desirable;

Therefore the council of the Township of Howick  
pursuant to the *Drainage Act* enacts as follows:

**1. AUTHORIZATION**

The attached report is adopted and the drainage works is authorized and shall be completed as specified in the report.

**2. BORROWING**

The Corporation of the Township of Howick  
may borrow on the credit of the Corporation the amount of \$318,000.00 being the amount necessary for  
the improvement of the drainage works.

This project will NOT be debentured.

**3. DEBENTURE(S)**

The Corporation may issue debenture(s) for the amount borrowed less the total amount of:

- (a) grants received under section 85 of the *Drainage Act*;
- (b) monies paid as allowances;
- (c) commuted payments made in respect of lands and roads assessed with the municipality;
- (d) money paid under subsection 61(3) of the *Drainage Act*; and
- (e) money assessed in and payable by another municipality.

**4. PAYMENT**

Such debenture(s) shall be made payable within \_\_\_\_\_ years from the date of the debenture(s) and shall bear interest at a rate not higher than 2% more than the municipal lending rates as posted by Infrastructure Ontario on the date of sale of such debenture(s).

- (1) A special equal annual rate sufficient to redeem the principal and interest on the debenture(s) shall be levied upon the lands and roads as shown in the schedule and shall be collected in the same manner and at the same as other taxes are collected in each year for \_\_\_\_\_ years after the passing of this by-law.
- (2) For paying the amount \_\_\_\_\_ being the amount assessed upon the lands and roads belonging to or controlled by the municipality a special rate sufficient to pay the amount assessed plus interest thereon shall be levied upon the whole rateable property in the Township of Howick in each year for \_\_\_\_\_ years after the passing of this by-law to be collected in the same manner and at the same time as other taxes collected.
- (3) All assessments of \_\_\_\_\_ or less are payable in the first year in which the assessments are imposed.

**5. SCHEDULE OF ASSESSMENTS OF LANDS AND ROADS**

in the Township of Howick

Property Description				Equal Annual Rate to be Imposed
Lot or Part Lot No.	Concession	Geographic Township	Parcel Roll No.	
<b>Total</b>				

6. CITATION

This by-law comes into force on the passing thereof and may be cited as the " Merkley Municipal Drain by-law".

First reading 2026/06/16

Second reading 2026/06/16

Provisionally adopted this 16 day of June, 20 26

Name of Head of Council (Last, First Name) <u>Harding, Doug</u>	Signature
--------------------------------------------------------------------	-----------

Name of Clerk (Last, First Name) <u>Gillis, Caitlin</u>	Signature
------------------------------------------------------------	-----------

Third reading 2026/08/11

Enacted this 11 day of August, 20 26

Name of Head of Council (Last, First Name) <u>Harding, Doug</u>	Signature
--------------------------------------------------------------------	-----------

Name of Clerk (Last, First Name) <u>Gillis, Caitlin</u>	Signature
------------------------------------------------------------	-----------

I, Caitlin Gillis  
clerk of the Corporation of the Township of Howick,  
certify that the above by-law was duly passed by the council of the Corporation and is a true copy thereof.

Name of Clerk (Last, First Name) <u>Gillis, Caitlin</u>	Signature
------------------------------------------------------------	-----------



# Staff Report to Council

---

**Report From:** Amy Van Meeteren, Treasurer/Manager of Finance

**Meeting Date:** June 16, 2026

**Report:** FIN-2026-18  
Insurance Renewal July 2026 to July 2027

---

## **Recommendation:**

**That Howick Council of the Township of Howick approve the municipal insurance coverage presented in the July 1, 2026 to July 1, 2027 Renewal Report by Intact Insurance at a cost of \$161,037.**

## **Report Highlights**

The 2026-2027 Renewal includes such changes as:

- 3.24% increase
- 4% inflationary increase to all Buildings and Structures estimated values

## **Impact Analysis**

For the previous insurance term, the annual premium was \$155,987 plus tax at the time of renewal. After endorsements were added throughout the 2025-2026 term the annual premium ended up being \$158,572 plus tax. The renewal term from July 1, 2026, to July 1, 2027, is presented as \$161,037 plus tax. This represents an increase of 3.24% from the last renewal, but an increase of only 1.55% when endorsements are considered. The 2026-2027 renewal amount was included in the 2026 budget.

This insurance coverage does not include the On Duty and Off Duty Fire Coverage, as it is provided through VFIS of Canada.

## **Linkages**

- [2026 Municipal Insurance Program](#)
- [Building and Structures and Other Property Values](#)

---

**Respectfully submitted,**

**Amy Van Meeteren, Treasurer/Manager of Finance**



# 2026 Municipal Insurance Program CORPORATION OF THE TOWNSHIP OF HOWICK

Renewal Report for the Policy Term July 1, 2026 to July 1, 2027

In Partnership with:  
Breanne Chapman  
McDonagh Insurance Brokers Ltd.  
573 Campbell Street  
Lucknow, ON N0G 2H0

Submitted by: Intact Public Entities Inc.  
Address: 278 Pinebush Rd., Suite 200  
Cambridge, ON N1T 1Z6

phone: 1-800-265-4000  
email: [connectwithus@intactpublicentities.ca](mailto:connectwithus@intactpublicentities.ca)

Prepared by:  
Tony Commisso, CAIB  
Regional Manager

Ref 11 June 2026  
34350/ed



# About IPE

IPE is a Canadian leader in providing specialized insurance programs, including risk management and claims services to municipal, public administration and community-based organizations across Canada. Proven industry knowledge, gained through over nine decades of partnering with insurance companies and independent brokers, gives IPE the ability to effectively manage the necessary risk, advisory and claims services for both standard and complex issues. IPE is a wholly-owned subsidiary of Intact Financial Corporation with its head office located in Cambridge, Ontario. For additional information about IPE visit [www.intactpublicentities.ca](http://www.intactpublicentities.ca).

IPE is a Managing General Agent (MGA) with the authority to write and service business on behalf of strategic partners who share our commitment and dedication to protecting specialized organizations. Because our partners are long-term participants on our program, they understand the nature of fluctuating market conditions and complex claims and are prepared to stay the course.

IPE is a licence-holder through the Registered Insurance Brokers of Ontario (RIBO) and in multiple jurisdictions across Canada, and as such we are required to disclose our professional duties and obligations to you as a current or potential client. Learn about our principles of conduct, how we are compensated by the insurers we represent, and see our privacy policy by reviewing the following:

[Code of Consumer Rights and Responsibilities](#)

[CISRO Code of Conduct for Insurance Intermediaries and Fact Sheet – About Your Registered Insurance Broker](#)

[Broker Compensation Disclosure](#)

[Our Privacy Promise](#)

## Canadian Owned Company With 90+ Years of Continuous Operation

### Market Leader

**Municipal, Public Administration  
& Community Services**

Municipal market share leader in Ontario with strong representation of municipal, public administration and community-based organizations across Canada.

### Innovative

**New Products & Services**

Cyber Risk Insurance  
Fraudulently Induced Transfer  
Road Reviews  
Fleet Management

### In-House

**Claims & Risk Management**

In-house claims management = faster turn around, single point of contact, specialized expertise in the municipal claims environment.



**Municipal Market Share  
Leader in Ontario**



**First Municipal Client  
The Village of Ayr, Ontario**

## The Advantage of a Managing General Agent

The MGA model is different than a traditional broker/insurer arrangement in that an MGA provides specialized expertise in a specific, niche area of business. As an MGA we also offer clients additional and helpful services in the area of risk management, claims and underwriting. And unlike the reciprocal model, a policy issued by an MGA is a full risk transfer vehicle not subject to retroactive assessments but rather a fixed term and premium.

We invite you to work with a partner who is focused on providing a complete insurance program specific to your organization that includes complimentary value added services that help drive down the cost of claims and innovative first to market products and enhancements. You will receive personalized service and expertise from a full-service, local and in-house team of risk management, claims, marketing and underwriting professionals.

As a trusted business partner, we believe in participating in and advocating for the causes that affect our clients. For this reason, we affiliate with and support key provincial and national associations. In order for IPE to be effective in serving you, we, as an MGA, believe in fully understanding your needs, concerns and direction. Our support is delivered through thought leadership, financial resources, advocacy, services, education and more.

## Risk Management Services

We are the leader in specialized risk management and place emphasis on helping your organization develop a solid plan to minimize exposure before potential incidents occur. Risk management is built into our offerings for all clients, fully integrated into every insurance program. Our risk management team is comprised of analysts, risk control consultants and engineers who use their expertise to help mitigate risk. We do everything we can to minimize your exposure before potential incidents occur. This includes providing education, road reviews, fleet reviews, contract analysis and property inspections.

## Claims Management Services

Our in-house team of experts has the depth of knowledge, experience and commitment to manage the complicated details of claims that your organization may experience. You deal with the public often in sensitive instances where serious accusations can be made. Your claims are often long-tail in nature and can take years to settle. Some claims aren't filed until years after the occurrence or accident. You want a team of professionals on your side that will vigorously defend your reputation. We understand your risks and your exposures and have maintained a long-term commitment to understanding the complex issues your organization may face so that we can better service your unique claims requirements.



**MGA  
Advantage**



**Risk Management  
Services**



**Claims Management  
Services**

\*Please note that the information contained in this document is proprietary and confidential and is to be used for the sole purpose of determining the successful proponent. Permission must be obtained from Intact Public Entities prior to the release of any information contained herein for any other purpose than evaluating this submission.

# Best in Class Value Added Services

IPE offers more than just an insurance policy. As a leading MGA specializing in public entities, we provide Canadian municipalities with a complete insurance program. What's the difference? A vested interest in helping you reduce your total cost of risk while providing you with complimentary best in class value-added services that help improve your overall performance.

## Advocacy & Municipal Association Support

IPE employees are continually recruited to serve on legislative committees and are aware of changes that will be introduced. We can move quickly to help you begin to modify your policies and procedures to maintain regulatory compliance.

IPE advocates and supports your public entities across the country.



## Risk Management

### Asset Valuation and Risk Inspections

Inspections provide you with calculated reconstruction costs for insurance purposes and ensure insurance to value. Leveraging specialized software and advanced tools – including thermal imaging cameras and our Self-Inspection App – we identify and analyze potential areas of harm and provide risk recommendations to reduce the frequency and severity of incidents.

### Roads & Sidewalks

#### Road Risk Assessment

Non-repair of road liability claims are costly to defend, result in high court awards and greatly impact a municipality's cost of risk. To help municipalities minimize exposure to non-repair of road claims, road assessments can be employed to review documentation, compliance with the Ontario Traffic Manual, adequacy of policies and procedures and select road segments.

#### Sidewalk Services

Our sidewalk consulting services can help to reduce the frequency of falls on your sidewalks.

#### Driver Education

Fleets and individual drivers can receive comprehensive driver education through the use of seminars, tools and guidelines that assist with everything from pre-employment checklists and driver management policies to defensive and cooperative driving education.

#### Fleet Management Evaluation

Have your municipality's fleet risk management practices evaluated. Topics for review include: management structure with the fleet, areas of operation/travel, driver training/hiring practices and loss control management.

#### MMS Compliance

Our Minimum Maintenance Standards (MMS) compliance analysis focuses on reviewing your policies/procedures/ documentation and comparing these to the required standards set under the MMS as well as the best practices developed by the Good Roads.

## **Municipal Education**

We develop and provide customized sessions on specific risk issues for your municipality. These customized sessions can be tied to a claims review, documentation review, policy & procedure review or any risk issue facing your municipality.

We provide training on any topic of your choosing and can be offered either in-person or virtually. The sessions will be developed and delivered by specialists in the field and are recorded and made available to you so your managers can use them at any time to train new staff or as a refresher for existing staff.

## **Reviews & Analysis**

### **Contract Reviews**

This complimentary service is among our most popular because a third-party contract review can make a substantial difference. You'll receive valuable feedback and insight from a Paralegal on the suitability and effectiveness of liability provisions and insurance clauses in contracts and agreements.

### **Policy and Procedural Reviews**

Includes an audit of systems and processes to reduce potential losses within your organization. Reviews focus on identifying gaps or inconsistencies between written policies and procedures, operational procedures and current legislation. The review also includes a claims analysis to identify trends, patterns and adherence or its lack of to the written operational policies and procedures.

## **Risk Management Centre of Excellence**

The IPE [Risk Management Centre of Excellence](#) is an online resource that provides clients with the information and tools needed to manage a myriad of risk issues. The Centre of Excellence is the hub for articles, information, case studies, and useful templates that can transform your municipality's risk management results. The Centre of Excellence is available 24/7 and is continually updated with timely and relevant content.

# Claims Services

## Claims Management Best Practices Framework

Manage claims under your deductible with greater efficiency using our tested claims analytics and measures that are guaranteed to have a positive effect on cost savings. Couple this with strong claims and risk management and your organization will be better prepared to help mitigate and manage future incidents.

## In-House Claims Management Services

Your claims will be handled better. We have in-house claims authority – others may not. Why does this matter? You'll experience faster turnaround, one point of contact, reduced frustration, better claims resolution and improved expense management.

## Claims History Analysis

Identify the cause of claims and focus on trends and patterns to help eliminate risk sources so as to better identify risk trends and address them with mitigation techniques.

## Guidewire ClaimCenter® Claims Management

View the status of claims in addition to data mining capabilities for risk management purposes so as to better identify risk trends and address them with mitigation techniques.

## Claims Education

Customized municipal seminars on claims related topics delivered to solve specific risk issues.

## Expertise

Canadian municipal claims experience and expertise is important. Our understanding of the complex municipal landscape allows us to better service your unique claims requirements.

# Your Insurance Coverage

## Important Information

### General Information

The premium quoted is based on information provided at the date of this Report (the date is noted on the first page of this report/quotation). Additional changes to information are subject to satisfactory underwriting information and express approval by Intact Public Entities Inc. Changes in information and coverage may also result in premium changes.

For full details with respect to coverage, exclusions, conditions and limitations refer to the policy wordings.

### Wildfire and Flood Exposures

Due to the high risk of wildfires and active floods, Intact Public Entities Inc. is taking a very conservative approach to such exposures/natural disasters. We are currently reviewing all risks to determine if any part of a risk is within 50km of an active wildfire or 15km of an active flood event.

### Quoting and Binding Coverage Restrictions

The quote provided is only valid for 60 days. Should you require an extension beyond the 60 days from the date of this report, you must contact an underwriter at Intact Public Entities Inc. for written confirmation that the quotation is still valid.

Coverage quoted cannot be bound unless expressly agreed to in writing by an underwriter at Intact Public Entities. Intact Public Entities Inc. reserves the right to decline to bind coverage.

Your marketing representative can assist in co-ordinating your correspondence with the correct underwriter for the account should you wish a quotation extension or are requesting coverage be bound.

## Schedule of Coverage

(Coverage is provided for those item(s) indicated below)

### Casualty

Coverage Description	(\$) *Deductibles	(\$) Limit of Insurance
General Liability (Occurrence Form) <i>Broad Definition of Insured</i>	25,000	15,000,000 Per Occurrence No Aggregate
Voluntary Medical Payments	Nil	50,000 Per Person 50,000 Per Accident
Voluntary Property Damage	Nil	50,000 Per Occurrence 50,000 Annual Aggregate
Voluntary Compensation - Employees	Nil	50,000 Each Person 250,000 Annual Aggregate
Sewer Backup	25,000 Per Claimant	Included
Wrongful Dismissal (Legal Expense – Claims Made)	5,000	250,000 Per Claim 250,000 Aggregate
Forest Fire Expense	Nil	2,000,000 2,000,000 Aggregate
Abuse Liability – Claims Made Form	25,000	2,000,000 Per Claim 2,000,000 Aggregate
Abuse Liability Retroactive date: Jan 01, 2024		
Errors & Omissions Liability (Claims Made Form)	25,000	15,000,000 Per Claim No Aggregate
Non-Owned Automobile Liability		15,000,000
Legal Liability for Damage to Hired Automobiles	500	250,000
Environmental Liability (Claims Made Form)	25,000	3,000,000 Per Claim 5,000,000 Aggregate

\*Your deductible may be a Deductible and Reimbursement Clause (including expenses) refer to Policy Wordings

### Follow Form – Excess Liability Coverage Description

### (\$) Limit of Insurance

<b>Excess Limit</b>	10,000,000
<b>Underlying Policy</b>	<b>(\$) Underlying Limit</b>
General Liability	15,000,000
Abuse Exclusion Applies	
Errors & Omissions Liability	15,000,000
Non-Owned Automobile	15,000,000
Owned Automobile	15,000,000

**Total Limit of Liability (\$) 25,000,000**

## Schedule of Coverage

(Coverage is provided for those item(s) indicated below)

### Crime

Coverage Description	(\$)	Deductibles	(\$)	Limit of Insurance
Employee Dishonesty – Form A (Commercial Blanket Bond)			1,000,000	
Loss Inside the Premises (Broad Form Money & Securities)			500,000	
Loss Outside the Premises (Broad Form Money & Securities)			500,000	
Audit Expense			500,000	
Money Orders and Counterfeit Paper Currency			500,000	
Forgery or Alteration (Depositors Forgery)			1,000,000	
Computer and Transfer Fraud (Including Voice Computer Toll Fraud)			500,000	

### Accident

Coverage Description	(\$)	Deductibles	(\$)	Limit of Insurance
Board Members: Persons Insured Reeve, Deputy Reeve and Two (2) Councillors				
Board Members Accidental Death & Dismemberment			250,000	
Paralysis			500,000	
Weekly Income – Total Disability			500	
Weekly Income – Partial Disability			150	
Accidental Death of a Spouse while Travelling on Business			Included	
24 Hour Coverage Endorsement			Included	
Volunteers Accidental Death & Dismemberment			50,000	
Paralysis			100,000	
Weekly Income – Total Disability			500	
Weekly Income – Partial Disability			250	

### Conflict of Interest

Coverage Description	(\$)	Deductibles	(\$)	Limit of Insurance
Legal Fees Expenses		Nil	100,000 Per Claim No Aggregate	

### Legal Expense (Claims Made)

Coverage Description	(\$)	Deductibles	(\$)	Limit of Insurance
Legal Defence Cost		Nil	250,000 500,000 Aggregate	

## Schedule of Coverage

(Coverage is provided for those item(s) indicated below)

### Property

**Coverage is on an All Risk Basis unless otherwise specified. Basis of Settlement is Replacement Cost unless otherwise specified. The Deductible is on a Per Occurrence Basis.**

Coverage Description	(\$) Deductibles	Basis	(\$) Limit of Insurance
Property of Every Description - Blanket	25,000	RC	40,879,581
Scheduled Items	25,000		1,521,500
Coverage, Deductible and Basis of Settlement as per Schedule			
<b>Property Supplemental Coverage</b>			
(Included in the Total Sum Insured unless otherwise specified in the wording)			
Building By-laws	25,000		10,000,000
Building Damage by theft	25,000		Included
Debris Removal	25,000		Included
Electronic Computer Systems			
Electronic Computer Hardware and Media	25,000		Included
Electronic Computer Systems Breakdown			Not Insured
Electronic Computer Systems – Extra Expense			Not Insured
Extra Expense Period of Restoration	25,000		90 Days
Expediting Expense	25,000		Included
Fire or Police Department Service Charges	25,000		Included
First Party Pollution Clean-up	25,000		1,500,000
Fungi and Spores	25,000		10,000
Furs, Jewellery and Ceremonial Regalia			
Ceremonial Regalia	25,000		Included
Furs and Jewellery	25,000		25,000
Inflation Adjustment	25,000		Included
Live Animals Birds or Fish	25,000		25,000
Newly Acquired Property	25,000		1,000,000
Professional Fees	25,000		Included
Property and Unnamed Locations	25,000		Included

Property Temporarily Removed Including while on Exhibition and during Transit	25,000	Included
Recharge of Fire Protection Equipment Expense	25,000	Included
Sewer Backup and Overflow	25,000	Included

### **Municipal & Public Administration Extension Endorsement**

(In Addition to the Total Sum Insured unless specifically scheduled in the wording)

Accounts Receivable	25,000	500,000
Bridges and Culverts	25,000	50,000
Buildings Owned due to Non Payment of Municipal Taxes	25,000	100,000
Buildings in the Course of Construction Reporting Extension By Laws – Governing Acts	25,000	1,000,000
		25,000
<b>Consequential Loss Caused by Interruption of Services</b>		
On Premises	25,000	Included
Off Premises	25,000	1,000,000
Cost to Attract Volunteers Following a Loss	25,000	10,000
Docks, Wharves and Piers	25,000	100,000
Errors and Omissions	25,000	Included
Exterior Paved Surfaces	25,000	50,000
Extra Expense	25,000	500,000
<b>Fine Arts</b>		
At Insured's Own Premises	25,000	25,000
On Exhibition	25,000	100,000
Fundraising Expenses	25,000	10,000
Green Extension	25,000	50,000
<b>Growing Plants</b>		
Any One Item	25,000	1,000
Per Occurrence	25,000	100,000
Ingress and Egress	25,000	Included
Leasehold Interest	25,000	25,000
Master Key	25,000	25,000
Peak Season Increase	25,000	25,000
Personal Effects	25,000	25,000
Property of Others	25,000	25,000
Rewards: Arson, Burglary Robbery and Vandalism	25,000	25,000
Signs	25,000	Included
Vacant Property	25,000	1,000,000
Valuable Papers	25,000	500,000

### **Business Interruption**

Rent or Rental Value	25,000	500,000
----------------------	--------	---------

**Additional Endorsements**

Virus and Bacteria Exclusion

**Earthquake Coverage**

Earthquake Coverage	3% Minimum \$100,000	Included
---------------------	-------------------------	----------

**Notes Applicable to Earthquake Coverage**

1. Earthquake coverage applies to: all property insured unless it is specifically excluded. Specifically excluded property will be shown under **Changes to Your Insurance Program – Property** in this Report.
2. Deductible is applicable to each premises.

Earthquake Aggregate – Applicable to All Provinces	"Total Sum Insured" and "all coverages" as declared to the Insurer at the time of the "earthquake".
----------------------------------------------------	-----------------------------------------------------------------------------------------------------

**Flood Coverage**

Flood Coverage	\$ 50,000	Included
----------------	-----------	----------

**Notes Applicable to Flood Coverage**

1. Flood coverage applies to: all property insured unless it is specifically excluded. Specifically excluded property will be shown under **Changes to Your Insurance Program – Property** in this Report.
2. Deductible is applicable to each premises.

Flood Aggregate – Applicable to All Provinces	"Total Sum Insured" and "all coverages" as declared to the Insurer at the time of the "flood".
-----------------------------------------------	------------------------------------------------------------------------------------------------

**(\$) Total Amount of Insurance 45,071,081**

RC = Replacement Cost ACV = Actual Cash Value VAL = Valued

## Schedule of Coverage

(Coverage is provided for those item(s) indicated below)

### Equipment Breakdown (Advantage/BM31)

Coverage Description	(\$) Deductibles / Waiting Period	(\$) Limit of Insurance
Direct Damage	25,000	50,000,000 Per Accident
Extra Expense		50,000
Consequential Damage	25,000	50,000
Expediting Expense		Included
Hazardous Substances		500,000
Ammonia Contamination		500,000
Water Damage		500,000
Professional Fees		500,000
Interruption by Civil Authority		30 days
Errors and Omissions		500,000
Loss of Data		100,000
Selling Price		Included
By-Law Cover		Included
Off Premises Mobile Object		25,000
Brands and Labels		250,000
Environmental "Green" Coverage		250,000
Service Interruption		Included Within 2500 metres
Contingent Business Interruption		25,000
Public Relations Coverage		10,000
Gross Rents		500,000

## Schedule of Coverage

(Coverage is provided for those item(s) indicated below)

### Owned Automobile

Coverage Description	(\$) Deductibles	(\$) Limit of Insurance
<b>Liability</b>		
Bodily Injury		15,000,000
Property Damage		Included
Accident Benefits		As stated in Section 4 of the Policy
Uninsured Automobile		As stated in Section 5 of the Policy
<b>Direct Compensation – Property Damage</b>		
*This policy contains a partial payment of recovery clause for property damage if a deductible is specified for direct compensation-property damage.		
<b>Loss or Damage**</b>		
Specified Perils (excluding Collision or Upset)		
Comprehensive (excluding Collision or Upset)		
Collision or Upset		
All Perils	10,000	Included
<b>Endorsements</b>		
Replacement Cost		Included
Fire Department Vehicles		Included
Notice of Cancellation		90 Days
#20 - Coverage for Transportation Endorsement		1,200/Occ
#21B - Blanket Fleet Coverage		No Adjustment
#5 - Permission to Rent or Lease Automobiles and Extending Coverage to Specified Lessee(s)		Included
#32 - Use of Recreational Vehicle by Unlicensed Operators		Included
#44R - Family Protection Coverage		1,000,000
#47R – Optional Accident Benefits Coverage & Priority of Payment		Included

\* This policy contains a partial payment of loss clause.

A deductible applies for each claim except as stated in your policy.

## INDICATION OF TERMS

REFERENCE NUMBER:	7323075
COMPANY NAME:	Corp of The Township of Howick
TOTAL PAYABLE:	CAD3,145.00
Premium breakdown:	
Cyber & Privacy:	CAD1,940.00
Cyber Crime:	CAD1,020.00
Policy Administration Fee:	CAD185.00
BUSINESS OPERATIONS:	Municipality
LEGAL ACTION:	Worldwide
TERRITORIAL SCOPE:	Worldwide
AGGREGATE DEDUCTIBLE:	CAD2,500.00 in the aggregate
REPUTATIONAL HARM PERIOD:	12 months
INDEMNITY PERIOD:	12 months
TIME FRANCHISE:	8 hours
WORDING:	Cyber Proactive Response v4.0
ENDORSEMENTS:	Regulatory Statement (CAN) Schedule Of Information Notice Concerning Personal Information Code Of Consumer Rights And Responsibilities Ontario Commercial Liability Notice Service of Suit Clause
SUBJECTIVITIES:	This quote is subject to the following being provided by the stated deadline: <ul style="list-style-type: none"> <li>1. Satisfactory confirmation that you have downloaded &amp; registered our incident response mobile app, details of which can be found with your policy documents. (30 days post binding)</li> </ul>
POLICY PERIOD:	12 months
DATE OF ISSUE:	08 Jun. 2026
OPTIONAL EXTENDED REPORTING PERIOD:	12 months for 100% of applicable annualized premium
ADDITIONAL NOTES:	
SECURITY:	Lloyd's Underwriters and other insurers
UNDERWRITER:	Steven Smith

THIS INDICATION OF TERMS IS ONLY VALID FOR 30 DAYS FROM THE DATE OF ISSUE

## DECLARATIONS

### INSURING CLAUSE 1: CYBER INCIDENT RESPONSE

#### SECTION A: INCIDENT RESPONSE COSTS

Limit of liability: CAD1,000,000 each and every claim

#### SECTION B: LEGAL AND REGULATORY COSTS

Limit of liability: CAD1,000,000 each and every claim

#### SECTION C: IT SECURITY AND FORENSIC COSTS

Limit of liability: CAD1,000,000 each and every claim

#### SECTION D: CRISIS COMMUNICATION COSTS

Limit of liability: CAD1,000,000 each and every claim

#### SECTION E: PRIVACY BREACH MANAGEMENT COSTS

Limit of liability: CAD1,000,000 each and every claim

#### SECTION F: THIRD PARTY PRIVACY BREACH MANAGEMENT COSTS

Limit of liability: CAD1,000,000 each and every claim

#### SECTION G: POST BREACH REMEDIATION COSTS

Limit of liability: CAD50,000 each and every claim, subject to a maximum of 10% of all sums we have paid as a direct result of the cyber event

### INSURING CLAUSE 2: CYBER CRIME

#### SECTION A: FUNDS TRANSFER FRAUD

Limit of liability: CAD250,000 each and every claim

#### SECTION B: INVOICE MANIPULATION

Limit of liability: CAD250,000 each and every claim

#### SECTION C: NEW VENDOR FRAUD

Limit of liability: CAD250,000 each and every claim

#### SECTION D: PHYSICAL GOODS FRAUD

Limit of liability: CAD250,000 each and every claim



**SECTION E: THEFT OF PERSONAL FUNDS**

**Limit of liability:** CAD250,000 each and every claim

**SECTION F: CORPORATE IDENTITY THEFT**

**Limit of liability:** CAD250,000 each and every claim

**SECTION G: THEFT OF FUNDS HELD IN ESCROW**

**Limit of liability:** CAD250,000 each and every claim

**SECTION H: THEFT OF CLIENT FUNDS**

**Limit of liability:** CAD50,000 each and every claim

**SECTION I: CUSTOMER PAYMENT FRAUD**

**Limit of liability:** CAD50,000 each and every claim

**SECTION J: TELEPHONE HACKING**

**Limit of liability:** CAD250,000 each and every claim

**SECTION K: UNAUTHORIZED USE OF COMPUTER RESOURCES**

**Limit of liability:** CAD250,000 each and every claim

**INSURING CLAUSE 3: CYBER EXTORTION**

**Limit of liability:** CAD1,000,000 each and every claim

**INSURING CLAUSE 4: SYSTEM DAMAGE AND BUSINESS INTERRUPTION**

**SECTION A: SYSTEM DAMAGE AND RECTIFICATION COSTS**

**Limit of liability:** CAD1,000,000 each and every claim

**SECTION B: HARDWARE REPLACEMENT COSTS**

**Limit of liability:** CAD1,000,000 each and every claim

**SECTION C: INCOME LOSS AND EXTRA EXPENSE**

**Limit of liability:** CAD1,000,000 each and every claim

**SECTION D: EMERGENCY AND ADDITIONAL OPERATIONAL CONTINUITY COSTS**

**Limit of liability:** CAD100,000 each and every claim



**SECTION E: VOLUNTARY AND REGULATORY SHUTDOWN**

Limit of liability: CAD1,000,000 each and every claim

**SECTION F: DEPENDENT BUSINESS INTERRUPTION**

Limit of liability: CAD1,000,000 each and every claim

**SECTION G: CONSEQUENTIAL REPUTATIONAL HARM**

Limit of liability: CAD1,000,000 each and every claim

**SECTION H: LOST OR MISSED BIDS**

Limit of liability: CAD1,000,000 each and every claim

**SECTION I: CLAIM PREPARATION COSTS**

Limit of liability: CAD25,000 each and every claim

**INSURING CLAUSES 5 AND 7 - 9 COMBINED**

Aggregate limit of liability: CAD1,000,000 in the aggregate

**INSURING CLAUSE 5: NETWORK SECURITY & PRIVACY LIABILITY**

**SECTION A: NETWORK SECURITY LIABILITY**

Aggregate limit of liability: CAD1,000,000 in the aggregate, including costs and expenses

**SECTION B: PRIVACY LIABILITY**

Aggregate limit of liability: CAD1,000,000 in the aggregate, including costs and expenses

**SECTION C: MANAGEMENT LIABILITY**

Aggregate limit of liability: CAD1,000,000 in the aggregate, including costs and expenses

**SECTION D: REGULATORY FINES, PENALTIES AND INVESTIGATION COSTS**

Aggregate limit of liability: CAD1,000,000 in the aggregate, including costs and expenses

**SECTION E: PCI FINES, PENALTIES AND ASSESSMENTS**

Aggregate limit of liability: CAD1,000,000 in the aggregate, including costs and expenses

**SECTION F: CONTINGENT BODILY INJURY**

Aggregate limit of liability: CAD250,000 in the aggregate, including costs and expenses



#### INSURING CLAUSE 6: CRIMINAL REWARD COVER

Limit of liability: CAD100,000 each and every claim

#### INSURING CLAUSE 7: MEDIA LIABILITY

##### SECTION A: DEFAMATION

Aggregate limit of liability: CAD1,000,000 in the aggregate, including costs and expenses

##### SECTION B: INTELLECTUAL PROPERTY RIGHTS INFRINGEMENT

Aggregate limit of liability: CAD1,000,000 in the aggregate, including costs and expenses

#### INSURING CLAUSE 8: TECHNOLOGY ERRORS AND OMISSIONS

NO COVER GIVEN

#### INSURING CLAUSE 9: COURT ATTENDANCE COSTS

Aggregate limit of liability: CAD100,000 in the aggregate

# Cost Analysis

	Expiring Program Term	Renewal Program Term
	_____	_____
<b>Casualty</b>		
General Liability	\$ 45,500	\$ 46,883
Errors and Omissions Liability	6,223	6,410
Non-Owned Automobile Liability	210	214
Environmental Liability	7,104	7,317
Crime	1,705	1,739
Board Members Accident	797	813
Volunteers' Accident	500	510
Conflict of Interest	310	316
Legal Expense	1,500	1,515
Cyber	2,960	2,960
<b>Property</b>		
Property	56,471	58,331
Equipment Breakdown	5,600	5,768
<b>Automobile</b>		
Owned Automobile	27,692	26,261
<b>Excess</b>		
Follow Form- 1 <sup>st</sup> layer	2,000	2,000
<b>Total Annual Premium</b>	<b>\$ 158,572</b>	<b>\$ 161,037</b>
(Excluding Taxes Payable)		

# Changes to Your Insurance Program

For full details with respect to coverage, exclusions, conditions and limitations refer to the policy wordings.

Please be advised of the following changes to your insurance program that now apply:

## Property Policy

### Building Values Increased

- Building values have been increased in order to reflect inflationary trends.

### Contractors Equipment (Owned or Leased)

- Currently we insure equipment (owned or leased) primarily on Replacement Cost regardless of age. The following changes will apply at renewal:
  - Blanket Replacement Cost will only be available on equipment 5-years or newer.
  - Contractors Equipment aged 6 to 15 years will be scheduled, and replacement cost will only be offered if Contractors Equipment reflects today's Market Prices.
  - Anything older than 15-years will be amended to Actual Cash Value.

## Automobile Policy

### Policy Number

- Please note that the policy number has been amended to FMA199886.
- The OPCF 47 and OPCF 32 have been included.

## General Conditions and Cancellation Clause Updates

- We have reviewed and made changes to ensure the cancellation clauses in all of our wordings will be the **same** for all coverage/lines of business/policies we issue for a client - E.g. the Insured can cancel anytime, the Insurer can cancel when 15 days notice of cancellation is for nonpayment of premium and the specified number of days number of days shown in the appropriate cancellation clause for any other reason (typically 90 days). **While most cancellation clauses were similar, it must be noted that the Not For Profit Directors and Officers policy can now be cancelled by the Insurer in the same manner as any other policy/coverage. Please refer to your policy wordings for full details.**

## General Conditions Update

- Where there were 'conditions' within a specific wording, we have clarified that there is any conflict between those conditions and any conditions as shown in Form number GNGX3569 (General Conditions applicable to Ontario, New Brunswick, Nova Scotia, Prince Edward Island and Newfoundland ) or GNGX3755 (General Conditions applicable to British Columbia, Alberta, Manitoba, Northwest Territories, Nunavut, Saskatchewan and Yukon), only the conditions found in GNGX3569 or GNGX3755 shall prevail.

# Program Options

Intact Public Entities offers a comprehensive insurance program. Outlined below are the program options, followed by your current coverage highlights.

## Property Coverage – Income Replacement

- Income can change from year to year so it is important to annually review your Business Interruption needs.
- Higher limits or Optional Coverages to protect your income are available.
- All income producing facilities need to be considered (e.g. arenas, pools, libraries, community halls etc.)

## Drone (UAV) Coverage

- Property and/or Liability Cover may be available for your Drone (UAV)
- Application required to quote.
- For Coverage information refer to the Drone (UAV) Coverage Highlight Sheet.



## Description of Coverage

IPE offers a Comprehensive Insurance Program to meet your needs.

"Your Insurance Coverage" provides a schedule of proposed coverages, limits and deductibles included in this proposal.

Highlights of coverage follow, providing a summary of coverage. Highlight pages may include a description of optional coverages.

The information provided by Intact Public Entities Inc. is intended to provide general information only. For full details with respect to coverage, exclusions, conditions and limitations refer to the policy wordings. While coverage may be quoted, once a policy is issued coverage is only applicable if shown on Declaration Page or Schedule of Coverage. Intact Design® is a registered trademark of Intact Financial Corporation. All other trademarks are properties of their respective owners. TM & © 2025 Intact Public Entities Inc and/or its affiliates. All Rights Reserved.

# Municipal Liability Coverage Highlights

## Overview

---

We are specialists at insuring Municipal & Public Administrations. Our liability wording has been specially designed to meet the unique needs of these types of risks.

## Coverage

---

- Limits up to \$50,000,000 Available.
- Occurrence coverage with No General Aggregate.
- Territory – World-wide for all coverage.
- Products and Completed Operations – liability arising out of the Insured's operations conducted away from the Insured's premises once those operations have been completed or abandoned.
- Bodily Injury including coverage for assault and battery.
- Personal Injury coverage - broad coverage (including advertising coverage) for acts that violate or infringe on the rights of others.
- Liquor Liability for bodily injury or property damage imposed upon an Insured by a Liquor Liability Act.
- Blanket Contractual for liability assumed by the Insured in contracts, whether reported to the Insurer or not.
- Products Liability - legal liability incurred by an Insured because of injury or damage resulting from a product's exposure.
- Professional/Malpractice Liability including for bodily injury or property damage from professional exposures.
- Employers Liability providing coverage for liability to employees for work-related bodily injury or disease, other than liability imposed on the Insured by a workers compensation law.
- Sewer backup Liability
- Watercraft Liability - full coverage with no restrictions.
- Tenants legal liability
- Cross Liability
- Broad Definition of Insured.

## Common Endorsements

---

In addition to the base wording, we have many optional endorsements to tailor coverage for individual accounts including:

- Wrongful Dismissal (Legal Expense)
- Forest Fire Expense
- Marina Liability Extension
- Sexual Abuse Therapy and Counselling Extension for long term care homes.
- Other endorsements specifically crafted for a particular exposure.

## Coverage is Provided for Unique Exposures

---

- Products and Completed Operations Aggregate Limit may come into play for exposures such as road maintenance, snow removal, garbage collection / waste disposal, street cleaning or other duties that the Insured Municipality has to perform on behalf of third parties.
- Assault and battery coverage is imperative when there are security exposures (e.g. police).
- Products exposures such as utilities (e.g. water) are covered.
- Full Malpractice including Medical Malpractice as well as professional exposures are covered.
- Professional exposures include those such as medical, engineering, design errors or building inspection operations.

# Municipal & Public Administration Errors and Omissions Liability Coverage Highlights

## Municipal & Public Administration Errors and Omissions Insurance

Municipal & Public Administration Errors and Omissions Insurance (E&O) Coverage protects risks from civil litigation caused by allegations of professional negligence or failure to perform professional duties. Errors and Omissions focuses on providing coverage when there is financial loss to a third party (rather than bodily injury or property damage as general liability does).

### Features

<b>Limits</b>	Typically limits follow that of our Liability. We have the availability to offer up to \$50,000,000.
<b>Defence Costs</b>	Over and above the Limit of Insurance. Whether a potential claim is baseless, or not, mounting legal expense can have serious monetary consequences for an Insured.
<b>No Annual Aggregate</b>	With higher out of court settlements and increased damage awards, large or even a series of small claims can quickly erode an annual aggregate limit.
<b>Claims Made Policy</b>	Pays for claims occurring and reported during the policy period. Our policy provides retroactive coverage (no date need be specified) and stipulates that a claim is first known only when written notice is first received.
<b>Claims Definition</b>	The definition of claim also includes arbitration, mediation or alternative dispute resolution proceedings.
<b>Insured Definition</b>	Includes Councilors, Statutory Officers, Council Committees, Firefighters, Employees and Volunteers.

### Coverage Is Provided For Unique Exposures

<b>Insurance</b>	No exclusion for failure to procure or maintain adequate insurance bonds or coverage (e.g. construction projects).
<b>Benefit Plans</b>	Errors or Omissions in administering Employee Benefit Plans are covered.
<b>Misrepresentations</b>	Municipal governments are required to provide information with respect to local matters and must ensure the information which is provided is accurate, true and not misleading. Our definition of a Wrongful Act covers misstatements or misleading statements
<b>Other Specialists and Services</b>	Covers errors or omissions when they are rendered in connection with operations that are typical of public sector such as those of building inspections, zoning, planning, developing or regulating by-laws. Officials and employees acting in good faith are often times the subject of lawsuits.

# Non-Owned Automobile Coverage Highlights

## Overview

---

Non-Owned and hired automobile liability insurance covers bodily injury and property damage caused by a vehicle not owned by the Insured (including rented or borrowed vehicles). Coverage is provided for Third Party Liability arising from the use or operation of any automobile not owned or licensed in the name of the Insured if it results in bodily injury (including death), property damage (if the property was not in possession of the Insured) to a third party.

## Features

---

### SEF No. 96 Contractual Liability:

- When renting a vehicle you engage in a contractual relationship with the rental company where you assume liability for the operation of the automobile. It is therefore important that contractual coverage is added to the policy by way of an endorsement known as SEF (Standard Endorsement Form) No. 96. Contractual Liability coverage is automatically provided for all written contractual agreements with our Non-Owned Automobile coverage.

### SEF No. 99 Long Term Lease Exclusion:

- When Contractual Liability is provided under the policy there is also an exclusion for Long Term Leased vehicles SEF No. 99. This excludes coverage for vehicles hired or leased for longer than a certain period such as 30 days.

### Territory:

- The Non-Owned Automobile policy provides coverage while in Canada and United States.

### Termination Clause:

- The standard termination clause has been amended in that the Insured may still provide notice of cancellation at any time, however, the Insurer must provide ninety days' notice of cancellation to the Insured rather than the standard 15 or 30 days.

### SEF No. 94 Legal Liability (Physical Damage) to a Hired/Rented Automobile:

- We automatically provide coverage for damage to a vehicle that you have hired or rented. Coverage is provided via endorsement SEF No. 94. We automatically provide 'All Perils' coverage. The limit of coverage will vary per client.

## Additional Information

---

Courts have repeatedly held that when an automobile is used on a person's behalf or under a person's direction, that person (or entity) has a responsibility for the operation of the automobile and may be held liable for damages in the event of an accident even though he or she is not the owner or driver of the vehicle. This common law principle has been supported by a number of court decisions making an employer responsible for the use and operation of an automobile when an employee is operating an automobile (not owned by the employer) while being used for the employer's business.

# Environmental Coverage Highlights

## Overview

---

Pollution incidents are a significant risk that can result in serious harm to public health and safety as well as to the environment.

We provide pollution liability insurance for claims for third-party bodily injury and property damage. Coverage is provided on a blanket basis resulting from pollution conditions on or migrating from premises owned, occupied, rented or leased by the Insured that are discovered and are reported during the policy period. The policy responds to events that are gradual in nature as well as those that are sudden and accidental, causing third-party damage whether pollutants are released on land, into the atmosphere or in the water.

## Features

---

### Defence Costs

- Our Defence costs are over and above the limit of insurance and will respond even if allegations are groundless or false.

### Storage Tanks

- Seepage or leakage from both above and below ground storage tanks are covered without being specifically listed on the policy.

### Territory

- Worldwide territory.

### Limits of Insurance

- Both a 'per incident' and an 'aggregate' limit is applicable.

## Additional Information

---

Environmental exposures pose an imminent and substantial threat to public health, safety or welfare or to the environment. Exposures could stem from: wastewater treatment plants, electric utility plants, construction sites, flood and rainwater runoff or retention basins, underground fuel storage tanks, herbicides, pesticides, and fertilizers, road salts and chemicals used to de-ice roads and bridges, contaminated waste from medical facilities or health clinics, marina's, fire-fighting chemicals or even contaminated swimming pools.

An environmental exposure arising from sewers is covered under our liability.

# Crime Coverage Highlights

## Overview

---

Our crime coverage is one of the broadest and most flexible in the industry. An Insured may elect to purchase any or all of the Standard Crime Coverage we have available. In addition to the Standard crime coverage the Insured may elect to also purchase any of our Optional Coverages.

### Optional Crime Coverage Includes:

- Extortion Coverage (Threats to persons and property).
- Pension or Employment Benefit Plan coverage.
- Residential Trust Fund Coverage.
- Credit Card Coverage.
- Client Coverage (Third Party Bond).
- Fraudulently Induced Transfer Coverage (otherwise known as Social Engineering). *Separate Coverage Highlights Sheet for Fraudulently Induced Transfer Coverage is available.*

For more information on our Optional Coverage refer to our **Crime Coverage Options Highlight Sheet**.

## Features of Our Standard Crime Coverage

---

Below is a brief description of the Standard Crime Coverage an Insured may elect to purchase:

### Employee Dishonesty – Form A Commercial Blanket Bond

- This protects the employer from financial loss due to the fraudulent activities of an employee or group of employees. The loss can be the result of theft of money, securities or other property belonging to the employer.

### Loss Inside and Loss Outside the Premises (Broad Form Money and Securities)

- Covers loss by theft, disappearance, or destruction of the Insured's money and securities inside the Insured's premises (or Insured's bank's premises) as well as outside the Insured's premises while in the custody of a messenger.

### Money Orders and Counterfeit Paper Currency

#### Covers Loss

- Due to acceptance of a money order that was issued (or is purported to have been issued) by a post office or express company; and
- From the acceptance of counterfeit paper currency of Canada or the United States.

### Forgery and Alteration

- Covers loss due to dishonesty from a forgery or alteration to a financial instrument (cheque, draft or promissory note).

### Audit Expense

- Coverage for the expenses that are incurred by the Insured for external auditors to review their books in order to establish the amount of a loss. This is a separate limit of insurance.

### Computer and Transfer Fraud (Including Voice Computer Toll Fraud)

- Loss caused when money, securities, or other property is transferred because of a fraudulent computer entry or change. The entry or change must be within a computer system that the Insured owns (and on their premises).
- Loss caused when money or securities are transferred, paid, or delivered from the Insured's account at a financial institution based on fraudulent instructions (at the financial institutions premises).
- Voice computer toll fraud covers the cost of long distance calls if caused by the fraudulent use of an account code or a system password.

# Board Members' (Including Councillors') Accidental Death and Dismemberment Coverage Highlights

<b>D&amp;D and Paralysis Limits</b>	<b>Option 1</b>	<b>Option 2</b>
Accidental Death or Dismemberment (including loss of life and heart attack coverage)	\$100,000	\$250,000
Paralysis Coverage – 200% of Accidental Death and Dismemberment Limit		
Permanent Total Disability - Accidental Death and Dismemberment Limit		

<b>Weekly Indemnity</b>	<b>Option 1</b>	<b>Option 2</b>
Total Loss of Time	\$300	\$500
Partial Loss of Time	\$150	\$300

## Accident Reimbursement - \$15,000

Chiropractor	Crutches <sup>†</sup>
Podiatrist/Chiropodist	Splints <sup>†</sup>
Osteopath	Trusses <sup>†</sup>
Physiotherapist	Braces (excludes dental braces) <sup>†</sup>
Psychologist	Casts <sup>†</sup>
Registered or Practical Nurse	Oxygen Equipment – Iron Lung
Trained Attendant or Nursing Assistant <sup>‡</sup>	Rental of Wheelchair
Transportation to nearest hospital <sup>†</sup>	Rental of Hospital Bed
Prescription drugs or Pharmaceutical supplies <sup>‡</sup>	Blood or Blood Plasma <sup>‡</sup>
Services of Physician or Surgeon outside of the province	Semi Private or Private hospital room <sup>‡</sup>

<sup>†</sup>Maximum \$1,000 per accident. <sup>‡</sup>If prescribed by physician

## Dental Expenses

Dental Expenses	\$5,000
-----------------	---------

## Occupational Retraining – Rehabilitation

Retraining – Rehabilitation for the Named Insured	\$15,000
Spousal Occupational Training	\$15,000

## Repatriation

Repatriation Benefit (expenses to prepare and transport body home)	\$15,000
--------------------------------------------------------------------	----------

## Dependent Children – Per Child

Dependent Children's Education (limit is per year- maximum 4 years)	\$10,000
Dependent Children's Daycare (limit is per year- maximum 4 years)	\$10,000

## Transportation/Accommodation (When Treatment Is Over 100km From Residence)

Transportation costs for the Insured when treatment is over 100km from home.	\$1,500
Transportation and accommodation costs when Insured is being treated over 100km from home.	\$15,000

## Home Alternation and Vehicle Modification

Expenses to modify the Insured's home and/or vehicle after an accident.	\$15,000
-------------------------------------------------------------------------	----------

## Seatbelt Dividend

10% of Principal Sum	\$25,000
----------------------	----------

## Funeral Expense

Benefit for loss of life	\$10,000
--------------------------	----------

## Identification Benefit

Benefit for loss of life \$5,000

## Eyeglasses, Contact Lenses and Hearing Aids

When Insured requires these items due to an accident. \$3,000

## Convalescence Benefit – Per Day

Insured Coverage \$100

One Family Member Coverage \$50

## Workplace Modification Benefits

Specialized equipment for the workplace. \$5,000

## Elective Benefits

### Complete Fractures

Skull	\$ 5,200	Foot & Toes	\$ 2,200
Lower Jaw	\$ 2,800	Two or More Ribs	\$ 1,900
Collar Bone	\$ 2,800	Colles' fracture	\$ 2,800
Shoulder Blade	\$ 3,500	Potts' fracture	\$ 3,400
Shoulder Blade complications	\$ 3,700	<b>Dislocation</b>	
Thigh	\$ 4,600	Shoulder	\$ 2,200
Thigh/hip joints	\$ 4,600	Elbow	\$ 2,200
Leg	\$ 3,500	Wrist	\$ 2,500
Kneecap	\$ 3,500	Hip	\$ 4,600
Knee/joint complications	\$ 4,000	Knee	\$ 3,500
Hand/Fingers	\$ 2,200	Bones of Foot or Toe	\$ 2,500
Arm (between shoulder & elbow)	\$ 4,600	Ankle	\$ 2,800
Forearm (between wrist & elbow)	\$ 2,800		

## Aggregate Limit

Aggregate Limit only applicable when 2 or more board members are injured in same accident. \$ 2,500,000

## Coverage Extensions

- Standard coverage is applicable while the Insured is 'On Duty'. Coverage for Accidents that may occur 24/7 may be purchased.
- Accidental Death of a Spouse While Travelling on Business is automatically included when this coverage is purchased. This endorsement provides for Accidental Death of a spouse when the spouse is travelling with an Insured Person on business. Coverage applies while travelling to or from such an event and /or if the loss of life occurs within one year of the accident.
- When Board Members' Accidental Death and Dismemberment Coverage is purchased, the Insured also has the option to purchase Critical Illness Coverage.

## Additional Information

- Loss of life payments up to 365 days from date of Accident or if permanently disabled up to 5 years.
- Weekly Indemnity coverage pays in addition to Elective Benefits.
- Weekly Indemnity payments take other income sources into consideration (e.g. automobile, CPP, group plans).
- Coverage is applicable to Insured 80 years of age or under.

# Volunteers' Accidental Death and Dismemberment Coverage Highlights

## AD&D and Paralysis Limits

Accidental Death or Dismemberment	\$50,000
Paralysis Coverage – 200% of Accidental Death and Dismemberment Limit	\$100,000

## Weekly Indemnity

Total Loss of Time	\$500
Partial Loss of Time	\$250

† Volunteer must be gainfully employed immediately prior to an accident for weekly indemnity benefits

## Accident Reimbursement - \$15,000

Chiropractor	Crutches†
Podiatrist/Chiropodist	Splints†
Osteopath	Trusses†
Physiotherapist	Braces (excludes dental braces) †
Psychologist	Casts†
Registered or Practical Nurse	Oxygen Equipment – Iron Lung
Trained Attendant or Nursing Assistant‡	Rental of Wheelchair
Transportation to nearest hospital†	Rental of Hospital Bed
Prescription drugs or Pharmaceutical supplies‡	Blood or Blood Plasma‡
Services of Physician or Surgeon outside of the	Semi Private or Private hospital room‡

†Maximum \$1,000 per accident. ‡If prescribed by physician.

## Dental Expenses

Dental Expenses	\$5,000
-----------------	---------

## Occupational Retraining – Rehabilitation

Retraining – Rehabilitation for the Volunteer	\$15,000
Spousal Occupational Training	\$15,000

## Repatriation

Repatriation Benefit (expenses to prepare and transport body home)	\$15,000
--------------------------------------------------------------------	----------

## Dependent Children – Per Child

Dependent Children's Education (limit per year- maximum 4 years)	\$10,000
Dependent Children's Daycare (limit per year- maximum 4 years)	\$10,000

## Transportation/Accommodation (When Treatment Is Over 100km From Residence.)

Insured Coverage	\$1,500
Family Member	\$15,000

## Home Alteration and Vehicle Modification

---

Expenses to modify the Insured's home and/or vehicle after an accident.	\$15,000
-------------------------------------------------------------------------	----------

### **Seatbelt Dividend**

---

10% of Principal Sum when proof of wearing a seatbelt.	\$5,000
--------------------------------------------------------	---------

### **Funeral Expense**

---

Benefit for loss of life.	\$10,000
---------------------------	----------

### **Identification Benefit**

---

Transportation and accommodation costs for family member to identify Insured's remains.	\$5,000
-----------------------------------------------------------------------------------------	---------

### **Eyeglass, Contact Lenses and Hearing Aids**

---

When Insured requires these items due to an accident.	\$3,000
-------------------------------------------------------	---------

### **Convalescence Benefit – Per Day**

---

Confined to hospital.	\$100
Outpatient.	\$ 50

### **Workplace Modification Benefits**

---

Specialized equipment for the workplace.	\$5,000
------------------------------------------	---------

### **Aggregate Limit**

---

Aggregate Limit only applicable when 2 or more volunteers are injured in same accident.	\$ 1,000,000
-----------------------------------------------------------------------------------------	--------------

### **Additional Information**

- 
- Loss of life payments up to 365 days from date of Accident Weekly Indemnity payments take other income sources into consideration (e.g. automobile, CPP, group plans).
  - Coverage is applicable to Insured 80 years of age or under.
  - Coverage is afforded to the Volunteer only when they are 'On Duty'.

# Conflict of Interest Coverage Highlights

## Overview

---

Conflict of Interest can be described as a situation in which public servants have an actual or potential interest that may influence or appear to influence the conduct of their official duties or rather divided loyalties between private interests and public duties.

Conflict of Interest coverage provides protection for the cost of legal fees and disbursements in defending a charge under the Municipal Conflict of Interest Act (or other similar Provincial Legislation in the respective province of the Insured).

## Features

---

Coverage is offered as a standalone coverage providing the client a separate limit of insurance that is not combined with any other coverage such as legal expense coverage.

- Per Claim Limit only – No Annual Aggregate.
- Coverage provided on a Reimbursement Basis.

## Coverage Description

---

Coverage is provided for legal costs an Insured incurs in defending a charge under the Provincial Conflict of Interest Act if a court finds that:

- There was no breach by the Insured; or
- The contravention occurred because of true negligence or true error in judgment; or
- The interest was so remote or insignificant that it would not have had any influence in the matter.

## Additional Information

---

Coverage is provided for elected or appointed members of the Named Insured including any Member of its Boards, Commissions or Committees as defined in the 'Conflict of Interest Act' while performing duties related to the conduct of the Named Insured's business.

Conflict of Interest coverage is applicable to only those classes of businesses that are subject to the Municipal Conflict of Interest Act (or other similar Provincial legislation in the respective province of the Insured).

# Legal Expense Coverage Highlights

## Coverage Features

---

We offer comprehensive Legal Expense Coverage to protect an Insured against the cost of potential legal disputes arising out of your operations.

- Coverage will pay as costs are incurred.
- Broad Core Coverage.
- Optional Coverage.
- Coverage for Appeals for Legal Defence Costs and any Optional Coverage purchased.
- Unlimited Telephone Legal Advice and access to Specialized Legal Representation in event of legal disputes.
- Additional Optional Coverage available.
- Broad Definition of Insured including managers, employees and volunteers.

## Broad Core Coverage

---

The core coverage provides Legal Defence Costs for:

- Provincial statute or regulation (including human rights tribunals).
- Criminal Code Coverage when being investigated or prosecuted. Coverage is applicable whether pleading guilty or a verdict of guilt is declared.
- Civil action for failure to comply under privacy legislation.
- Civil action when an Insured is a trustee of a pension fund for the Named Insured's employees.

## Optional Coverage

---

In addition to the Core Coverage an Insured can mix and match any of the following Optional Coverage:

- Contract Disputes and Debt Recovery
- Statutory License Protection
- Property Protection
- Tax Protection

## Limits and Deductibles

---

- Coverage is subject to a Per Claim and an Aggregate Limit.
- The Core Coverage is typically written with no deductible however a deductible may be applied to Optional Coverage.

## Exclusions

---

- Each Insuring Agreement is subject to Specific Exclusions and Policy Exclusions.
- Municipal Conflict of Interest Act (or other similar provisions of other Provincial legislation) is excluded.  
\* Conflict of Interest Coverage may be provided under a separate policy for eligible classes of business.

## Telephone Legal Advice and Specialized Legal Representation

---

- General Advice (available from 8 am until 12 am local time, 7 days a week).
- Emergency access to a Lawyer 24 hours a day, 7 days a week.
- Services now automatically include the option of using an appointed representative from a panel of Lawyers with expertise in a variety of areas.

## Client Material and Wallet Card

---

- The 'Legal Expense Important Information' wording attached to each policy explains the steps that are to be taken in event of a claim.
- A wallet card is now attached to the policy which the Named Insured can copy & distribute to each Insured (e.g. managers, employees, etc.).

The information provided by Intact Public Entities Inc. is intended to provide general information only. For full details with respect to coverage, exclusions, conditions and limitations refer to the policy wordings. While coverage may be quoted, once a policy is issued coverage is only applicable if shown on Declaration Page or Schedule of Coverage. Intact Design® is a registered trademark of Intact Financial Corporation. All other trademarks are properties of their respective owners. TM & © 2023 Intact Public Entities Inc and/or its affiliates. All Rights Reserved.

# Property Coverage Highlights

## Overview

---

Property insurance is about planning for the unexpected and protecting your physical assets in order to minimize your business disruption should a loss occur. It is important that your property insurance includes broad coverage to protect these assets (e.g. buildings and other property you own, lease or are legally liable for) from direct physical loss.

We will work closely with you to customize a property coverage solution. We cover a wide variety of property, including buildings, inventory and supplies, office furniture and fixtures, computers, electronics, equipment (including unlicensed mobile equipment, maintenance and emergency equipment) and other unique property.

The IPE property wording is flexible and adaptable. Your policy will be comprised of a Base Property Wording and a Municipal & Public Administration Extension of Coverage Endorsement as well as any miscellaneous or specific endorsements to tailor coverage to meet your needs.

## Features and Benefits

---

Features and Benefits include:

- Coverage is typically written on an all-risk basis including replacement cost.
- Our standard practice is to write property on a Property of Every Description (POED) or blanket basis, however, coverage can be scheduled separately if required.
- We have two Deductible Clauses: A standard Deductible Clause and a Dual Policy Deductible Clause. The Dual Policy Deductible clause states how a deductible will be applied when there is both an automobile policy and a property policy involved in the same loss (when both policies are written with IPE).
- Worldwide Coverage
- Unlicensed Equipment (e.g. Contractors Equipment): Automatically includes Replacement Cost as the basis of settlement up to five years in age. For years 6 to 15 coverage will be amended to scheduled, Replacement Cost value. Any Contractors Equipment over 15 years will be amended Actual Cash Value (ACV) or Valued basis if required (applicable only if the Insured owns the unlicensed equipment).
- Flood and Earthquake coverage are available.

## Supplemental Coverage Under the Base Property Wording

---

The Base Property Wording automatically includes numerous Supplemental Coverages such as:

- Building Bylaws
- Building Damage by Theft
- Debris Removal Expense
- Electronic Computer Systems
- Expediting Expense
- Fire or Police Department Service Charges
- First Party Pollution Clean-Up Coverage
- Fungi (covers the expense for any testing, evaluating or monitoring for fungi or spores required due to loss)
- Furs, Jewellery and Ceremonial Regalia
- Inflation Adjustment
- Live Animals, Birds or Fish
- Newly Acquired Property
- Professional Fees
- Property at Unnamed Locations
- Property Temporarily Removed including while on Exhibition and during Transit
- Recharge of Fire Protective Equipment
- Sewer Back Up and Overflow

**Note:** The Supplemental Coverage does not increase your Total Sum Insured in most cases.

## Municipal & Public Administration Extensions of Coverage Endorsement

---

Each Extension of Coverage has an individual Limit of Insurance and will be shown on the Summary of Coverage/Declarations Page.

The Limit of Insurance for each Extension of Coverage is over and above the Total Sum Insured (unless shown as 'included' on the declarations or otherwise stipulated within the wording).

- Accounts Receivable
- Bridges and Culverts
- Building Coverage Owned Due to the Non Payment of Municipal Taxes – *Named Perils Coverage applies.*
- Building(s) in the Course of Construction Reporting Extension
- By Laws – Governing Acts
- Consequential Loss caused by Interruption of Services
- Cost to Attract Volunteers Following a Loss
- Docks, Wharves and Piers
- Errors and Omissions
- Exterior Paved Surfaces
- Extra Expense
- Fine Arts at Own Premises and Exhibition Site
- Fundraising Expenses
- Green Extension
- Growing Plants
- Ingress and Egress
- Leasehold Interest
- Master Key
- Peak Season Increase
- Personal Effects
- Property of Others
- Rewards: Arson, Burglary, Robbery and Vandalism
- Signs
- Vacant Properties – *Named Perils Coverage applies on an Actual Cash Value basis.*
- Valuable Papers

# Equipment Breakdown Advantage Highlights

## Overview

---

Property policies typically exclude losses that Equipment Breakdown Insurance is designed to cover.

Equipment Breakdown Coverage insures against losses (property damage and business interruption) resulting from 'accidents' (as defined in the wording) to various types of equipment such as pressure, mechanical, electrical and pressure equipment. Coverage also extends to electronic equipment for 'electronic circuitry impairment'. Coverage typically extends to production machinery unless specifically excluded.

## Features

---

Coverage is extended to pay for:

**Property Damage:** The cost to repair or replace damaged equipment or other covered property, including computers, due to a covered accident.

**Business Income:** The loss of business income due to an interruption caused by a covered accident from the date of loss until such equipment is repaired or replaced or could have been repaired or replaced plus additional time to allow your business to become fully operational.

**Extra Expense:** Additional costs (e.g., equipment rental) you incur after a covered loss to maintain normal operations.

**Expediting Expenses:** The cost of temporary repairs or to expedite permanent repairs to restore business operations.

**Service Interruption:** Business income and extra expense resulting from a breakdown of equipment owned by a supplier with whom the Insured has a contract to supply a service. If there is no contract, the equipment must be within 2500 metres of the location.

**Data Restoration:** The restoration of data that is lost or damaged due to a covered loss.

**By laws:** The additional costs to comply with building laws or codes.

**Other Coverage:** Spoilage, Hazardous Substances, Ammonia, Water damage, Professional Fees, Errors and Omissions, Newly Acquired Locations or Civil Authority

## Coverage Automatically Includes:

---

**Microelectronics Coverage:** Provides insurance when physical damage is not detectable or when firmware or software failure causes non-physical damage. Triggered when covered equipment suddenly stops functioning as it had been and that equipment or a part containing electronic circuitry must be replaced.

**Service Interruption:** Pays for business interruption and extra expense when your cloud computing service provider experiences an outage due to an equipment breakdown.

**Off Premises Objects:** Extends coverage to transportable equipment anywhere in North America.

**Brands and Labels:** Pays for the cost of removing labels or additional cost of stamping salvaged merchandise after a loss.

**Equipment Upgrade:** Pays for any increase in the replacement of new equipment that is capable of performing the same functions that may include technological improvements, 25% max of \$250,000.

**Selling Price:** Pays for regular cash selling price at the time of loss of such manufactured products or merchandise at the location

## Other Benefits

---

**Public Relations Coverage:** (when business income coverage is purchased other than extra expense) pays for public relations assistance to help manage your reputation that may be damaged by business interruption or data loss.

**Contingent Business Interruption:** (when business income coverage is purchased other than extra expense) pays for Business Income resulting from a covered accident to property not owned, operated or controlled by the Insured.

## Additional Information

---

Intact automatically provides inspection services for boilers and pressure vessels to satisfy the provincial inspection requirements on our behalf.

# Owned Automobile Coverage Highlights

## Overview

---

We can provide mandatory automobile coverage for all licensed vehicles owned and/or leased by the Insured.

## Features

---

### Third Party Liability Coverage:

- Coverage is provided for Third Party Liability (bodily injury and property damage) protecting you if someone else is killed or injured, or their property is damaged. It will pay for claims as a result of lawsuits against you up to the limit of your coverage, and will pay the costs of settling the claims. Coverage is for licensed vehicles you own and/or leased vehicles.

### Standard Statutory Accident Benefits Coverage:

- We automatically provide standard benefits if you are injured in an automobile accident, regardless of who caused the accident. Optional Increased Accident Benefits Coverage is available upon written request.

### Optional Statutory Accident Benefits Coverage - Available upon request

- Including coverage for: Income Replacement; Caregiver, Housekeeping & Home Maintenance; Medical & Rehabilitation; Attendant Care; Enhanced Medical Rehabilitation & Attendant Care; Death & Funeral; Dependent Care; Indexation Benefit (Consumer Price Index) – Ontario

### Direct Compensation Property Damage:

- Covers damage to your vehicle or its contents, and for loss of use of your vehicle or its contents, to the extent that another person was at fault for the accident as per statute.

### Physical Damage Coverage:

- Various basis of settlement including: Replacement Cost, Valued Basis and Actual Cash Value. Refer to Owned Automobile Replacement Cost Coverage Highlights page for details on Replacement Cost Coverage.

## Additional Information

---

### Blanket Fleet Endorsement:

- Coverage may be provided on a blanket basis under the 21B – Blanket Fleet Endorsement. When this endorsement is attached to the policy, premium adjustment is done on renewal. Adjustment is made on a 50/50 or pro rata basis as specified in the endorsement. Mid-term endorsements are not processed on policies with this blanket cover.

### Single Loss:

- If a single loss involves both the Automobile and Property Insurance policies, the Property policy deductible is waived only on any insured property attached to the automobile.

For a list of vehicles quoted, refer to Exhibit "B".

# Commercial Follow Form Excess Liability Coverage Highlights

## Overview

---

Excess liability coverage provides an additional limit of insurance coverage over and above the limits of insurance afforded under the applicable underlying insurance. An excess policy offers you additional insurance protection over and above the limits of your underlying policy. Example if your underlying policy has an occurrence limit, an excess policy can provide additional protection in event of a catastrophic loss. It can provide added protection if an aggregate limit on an underlying policy has been exhausted.

The follow form excess policy typically “follows” the insuring agreements, exclusions, and conditions of the underlying policy. This means that we not only provide additional limits of liability over the primary liability policy, but such coverage matches the underlying policy (except in instances where an endorsement has been attached amending coverage).

We offer a layered structure when writing excess coverage. We provide **primary** insurance policies to a maximum limit of \$15,000,000 on the casualty policies (Liability, E&O, Miscellaneous Professional Including Bodily Injury or Claims Made Malpractice coverage (depending on your policy), Non Owned Automobile and Owned Automobile including garage coverage).

We have the ability to provide excess coverage over all classes of business where the primary policy is written by Intact Public Entities. We also have the capacity to provide you with exceptionally high excess limits to meet your needs.

## Coverage Specifics

---

- Coverage will attach in the event of exhaustion of underlying insurance (unless specifically shown in your policy documents).
- This coverage is subject to the same terms, definitions, conditions, exclusions and limitations of the applicable underlying insurance (except as otherwise stated in your policy). This feature provides the flexibility to provide excess limits over a number of different types of policies.
- Our Declaration Pages/Schedules of Coverage clearly identify underlying coverages that the excess coverage is written over.
- Underlying insurance is required to be maintained in full force and effect for excess coverage to apply.
- Prior and Pending Litigation is expressly excluded from coverage.
- Incident is a defined term and means an occurrence, accident, offence, act, or other event, to which the underlying insurance applies.
- S.P.F. 7, Standard Excess Automobile policy or the applicable form applies for any automobile coverage.
- Where an aggregate limit is stated in the Declarations pages, it will apply separately to each consecutive annual period and to any remaining period of less than twelve (12) months.
- Coverage can be tailored to your individual circumstances by way of endorsements.



## Program Options Highlights of Coverage

IPE offers a Comprehensive Insurance Program to meet your needs.

"Your Insurance Coverage" provides a schedule of proposed coverages, limits and deductibles included in this proposal.

Highlights of coverage follow, providing a summary of coverage. Highlight pages may include a description of optional coverages.

The information provided by Intact Public Entities Inc. is intended to provide general information only. For full details with respect to coverage, exclusions, conditions and limitations refer to the policy wordings. While coverage may be quoted, once a policy is issued coverage is only applicable if shown on Declaration Page or Schedule of Coverage. Intact Design® is a registered trademark of Intact Financial Corporation. All other trademarks are properties of their respective owners. TM & © 2023 Intact Public Entities Inc and/or its affiliates. All Rights Reserved.

# Remotely Piloted Aircraft Systems (UAV) Coverage Highlights

## Overview

---

- Transport Canada is responsible for regulating UAV's. Their terminology for UAV's (Unmanned Aerial Vehicles) has changed and these are now considered to be Remotely Piloted Aircraft Systems (RPAS) rather than UAV's (Unmanned Aerial Vehicles). Regulations regarding operator licensing has also changed.
- Liability or property policies can be enhanced with endorsements to cover Remotely Piloted Aircraft Systems (RPAS) or UAV's. Coverage may be available when operators are in compliance with current regulations. Coverage offered is intended to close the gap in liability and property insurance because of aviation exclusions.

## Property Coverage

---

- Property: (Optional Coverage).
- All Risk Coverage for the Remotely Piloted Aircraft Systems (RPAS) including all permanently attached equipment and Ground or Operating Equipment (including any detachable equipment such as cameras etc.).
- Coverage includes electrical and mechanical breakdown.
- Basis of settlement options include: Replacement Cost, Valued Amount or Actual Cash Value.
- **In addition to the standard exclusions within the Property All Risk Wording, the following exclusions also apply:**
- Those used for military purposes, personal or recreational use.
- Those being rented to, leased to or lent to others.
- Mysterious disappearance after commencement of a flight unless Remotely Piloted Aircraft Systems - RPAS (UAV) remains unrecovered for 30 days.
- If they are not in compliance with the manufacturer's specifications (e.g. the weight payload) is exceeded, when operated in wind at a higher speed than recommended etc.).
- Remotely Piloted Aircraft Systems - RPAS (UAV's) must not exceed 500 meters in altitude or the range of 1km from the operator.
- Hijacking or unauthorized control of the Remotely Piloted Aircraft Systems -RPAS (UAV) or Equipment.
- Failure to comply with any statute, permit, rule, regulation or any requirement for qualification to operate the Remotely Piloted Aircraft Systems - RPAS (UAV) or the equipment.

## Liability Coverage

---

- While Transport Canada mandates a minimum amount of insurance (\$100,000), coverage will follow the liability limit up to \$15,000,000. Higher limits may be available.
- We will extend liability to Remotely Piloted Aircraft Systems (RPAS).
- Having a range of up to a maximum of 1km from the operator.
- With an altitude of 500 metres or less.
- Operators meeting all Transport Canada regulations.
- Not being used for military purposes, personal or recreational use.

## Important Information

---

While our endorsements are primarily designed to offer coverage for Remotely Piloted Aircraft Systems - RPAS (UAV's) 25kg or less, we may be able to offer coverage for those falling outside of these parameters through our general aviation market.

The information provided by Intact Public Entities Inc. is intended to provide general information only. For full details with respect to coverage, exclusions, conditions and limitations refer to the policy wordings. While coverage may be quoted, once a policy is issued coverage is only applicable if shown on Declaration Page or Schedule of Coverage. Intact Design® is a registered trademark of Intact Financial Corporation. All other trademarks are properties of their respective owners. TM & © 2023 Intact Public Entities Inc and/or its affiliates. All Rights Reserved.

# EXHIBIT “A”

Estimate of Values

---

**The information contained herein is confidential, commercial, financial, scientific and/or technical information that is proprietary to Intact Public Entities Inc. and cannot be disclosed to others. Any such disclosure could reasonably be expected to result in significant prejudice to the competitive position of Intact Public Entities Inc., significant interference with its competitive position and/or cause it undue loss. TM & © 2023 Intact Public Entities Inc. and/or its affiliates. All Rights Reserved.**

---

## RENT OR RENTAL VALUE SCHEDULE

PROPERTY INSURED	AMOUNT	INDEMNITY PERIOD	CO-INSURANCE
RENTAL INCOME	\$ 500,000	12 Months	No Co-Insurance

---

<b>TOTAL</b>	\$ 500,000
--------------	------------

POLICY EFF: 01/07/2026

MODIFIED: 31/05/2026

RISK NO: 34350

QUOTE: 569769

STATUS: IN PROGRESS

CORPORATION OF THE TOWNSHIP OF HOWICK

EXHIBIT "A"

BUILDINGS AND STRUCTURES

01/07/2026

ESTIMATE OF VALUES

AGRICULTURE AND COMMUNITY CENTER

1	AGRICULTURAL EXHIBIT BUILDING, 45088 HARRISTON ROAD, FORDWICH, N0G 1V0	236,200
2	AGRICULTURAL EXHIBIT BUILDING, 45088 HARRISTON ROAD, FORDWICH, N0G 1V0	76,300
3	Insp ARENA, COMMUNITY CENTRE AND LIBRARY, 45088 HARRISTON ROAD, FORDWICH, N0G 1V0	12,198,500

BELMORE

4	Insp* ARENA/CURLING RINK, 91122 BELMORE LINE, WROXETER, N0G 2X0	13,692,400
5	SUGAR SHACK CONCESSION BOOTH, 91122 BELMORE LINE, WROXETER, N0G 2X0	37,200
6	PARK PAVILION AND TENNIS COURT, 91122 BELMORE LINE, WROXETER, N0G 2X0	40,200
7	BELMORE PARK BLEACHERS, 91122 BELMORE LINE, WROXETER, N0G 2X0	259,100
8	STORAGE SHED, 91122 BELMORE LINE, WROXETER, N0G 2X0	6,800
9	TWO (2) BALL DUGOUTS AND BACKSTOP, 91122 BELMORE LINE, WROXETER, N0G 2X0	19,300

FORDWICH

10	VILLAGE PARK PAVILION AND PLAYGROUND EQUIPMENT, 3010 STATION ROAD, FORDWICH, N0G 1V0	49,500
11	COLUMBARIUM, 3010 STATION ROAD, FORDWICH, N0G 1V0	27,800
12	CEMETERY STORAGE, 3010 STATION ROAD, FORDWICH, N0G 1V0	19,300
13	BALL PARK CANTEEN AND PAVILION, 3084 ALBERT STREET, FORDWICH, N0G 1V0	184,100
14	TENNIS COURT FENCING AND LIGHTS, 3084 ALBERT STREET, FORDWICH, N0G 1V0	118,100
15	TWO (2) BALL DUGOUTS, 3084 ALBERT STREET, FORDWICH, N0G 1V0	8,400

---

PROPRIETARY DATA : USE OR DISCLOSURE OF THE INFORMATION IN THIS DOCUMENT IS SUBJECT  
TO THE RESTRICTIONS ON THE TITLE PAGE

CORPORATION OF THE TOWNSHIP OF HOWICK

EXHIBIT "A"

BUILDINGS AND STRUCTURES

01/07/2026

ESTIMATE OF VALUES

16	WASHROOMS, 3084 ALBERT STREET, FORDWICH, N0G 1V0	71,100
17	FORDWICH PARK BLEACHERS, FLOODLIGHTS AND FENCING, 3084 ALBERT STREET, FORDWICH, N0G 1V0	220,700
18	FORDWICH PLAYGROUND EQUIPMENT, 3084 ALBERT STREET, FORDWICH, N0G 1V0	32,200
19	STORAGE 30X30, 3084 ALBERT STREET, FORDWICH, N0G 1V0	71,300

GENERAL

100	RENTAL INCOME	500,000	LIM REP
-----	---------------	---------	---------

GORRIE

20	Insp	FIRE HALL, 2005 NELSON STREET NORTH, GORRIE, N0G 1X0	1,334,600
21		TRAINING TOWER, 2005 NELSON STREET NORTH, GORRIE, N0G 1X0	12,900
22		STORAGE SHED, 2005 NELSON STREET NORTH, GORRIE, N0G 1X0	6,400
23	Insp	COMMUNICATION TOWER, 2005 NELSON STREET NORTH, GORRIE, N0G 1X0	78,000
24		OPTIMIST POOL AND PAVILION, PLAYGROUND EQUIPMENT, 2046 JAMES STREET, GORRIE, N0G 1X0	531,500
25		CEMETERY MAUSOLEUM, 2052 ALMA STREET SOUTH, GORRIE, N0G 1X0	96,600
26		COLUMBARIUM, 2052 ALMA STREET SOUTH, GORRIE, N0G 1X0	27,800
27		CEMETERY STORAGE, 2052 ALMA STREET SOUTH, GORRIE, N0G 1X0	22,500
28	Insp	COMMUNITY HALL, 2059 VICTORIA STREET, GORRIE, N0G 1X0	1,600,000
29		GORRIE PARK PAVILION, CONCESSION BOOTH, WASHROOMS AND PLAYGROUND, 2079 ALMA STREET SOUTH, GORRIE, N0G 1X0	126,500
30		GORRIE PARK DUGOUTS, 2079 ALMA STREET SOUTH, GORRIE, N0G 1X0	8,500
31		GORRIE PARK BLEACHERS, FLOODLIGHTS AND FENCING,	174,200

---

PROPRIETARY DATA : USE OR DISCLOSURE OF THE INFORMATION IN THIS DOCUMENT IS SUBJECT  
TO THE RESTRICTIONS ON THE TITLE PAGE

CORPORATION OF THE TOWNSHIP OF HOWICK

EXHIBIT "A"

BUILDINGS AND STRUCTURES

01/07/2026

ESTIMATE OF VALUES

		2079 ALMA STREET SOUTH, GORRIE, N0G 1X0	
32		GORRIE SPLASHPAD , 2046 JAMES STREET, GORRIE, N0G 1X0	277,800
		<u>LAKELET</u>	
33		COLUMBARIUM, 44924 LAKELET ROAD, LAKELET, N0G 1M0	16,300
		<u>LANDFILL</u>	
34		LANDFILL STORAGE, 45589 HARRISTON ROAD, FORDWICH, N0G 1V0	4,100
35		LEASED 16X8 OFFICE TRAILER, 45589 HARRISTON ROAD, FORDWICH, N0G 1V0	27,100
36		12 X10 FIBREGLASS LANDFILL OFFICE, 45589 HARRISTON ROAD, FORDWICH, N0G 1V0	30,200
		<u>MUNICIPAL OFFICE AND FUEL DEPOT</u>	
37	Insp	MUNICIPAL OFFICE, 44816 HARRISTON ROAD, FORDWICH, N0G 1V0	1,032,900
38	Insp	ABOVE GROUND FUELING CENTRE, 44816 HARRISTON ROAD, FORDWICH, N0G 1V0	215,800
39	Insp	EQUIPMENT DEPOT, 44816 HARRISTON ROAD, FORDWICH, N0G 1V0	1,795,100
40		STORAGE BUILDING, 44816 HARRISTON ROAD, FORDWICH, N0G 1V0	24,200
41	Insp	COMMUNICATION TOWER, 44816 HARRISTON ROAD, FORDWICH, N0G 1V0	78,000
42		SALT COVERALL, 44816 HARRISTON ROAD, FORDWICH, N0G 1V0	115,000
		<u>WROXETER</u>	
43		BALL PARK PAVILION AND BOOTH, PLAYGROUND, 1020 MARRIETTA STREET, WROXETER, N0G 2X0	125,800
44		BALL PARK STORAGE, 1020 MARRIETTA STREET, WROXETER, N0G 2X0	33,100
45		TWO (2) DUGOUTS, 1020 MARRIETTA STREET, WROXETER,	9,400

---

PROPRIETARY DATA : USE OR DISCLOSURE OF THE INFORMATION IN THIS DOCUMENT IS SUBJECT TO THE RESTRICTIONS ON THE TITLE PAGE

CORPORATION OF THE TOWNSHIP OF HOWICK

EXHIBIT "A"

BUILDINGS AND STRUCTURES

01/07/2026

ESTIMATE OF VALUES

N0G 2X0

46		WROXETER PARK BLEACHERS, FLOODLIGHTS AND FENCING, 1020 MARRIETTA STREET, WROXETER, N0G 2X0	169,100
47	Insp	WROXETER COMMUNITY HALL, 1094 CENTRE STREET, WROXETER, N0G 2X0	1,923,100
48		STORAGE BUILDING - SMALL, 1094 CENTRE STREET, WROXETER, N0G 2X0	9,000
49		PAVILLION AT DAM AND CENTRE STREET, 1094 CENTRE STREET, WROXETER, N0G 2X0	47,200
50		COLUMBARIUM, 43172 HIGHWAY 87, WROXETER, N0G 2X0	27,800
51		CEMETERY STORAGE, 43172 HIGHWAY 87, WROXETER, N0G 2X0	18,700

---

**TOTALS:**

<u>BLANKET</u>	<u>SPECIFIED</u>
37,367,700	500,000

---

PROPRIETARY DATA : USE OR DISCLOSURE OF THE INFORMATION IN THIS DOCUMENT IS SUBJECT  
TO THE RESTRICTIONS ON THE TITLE PAGE

CORPORATION OF THE TOWNSHIP OF HOWICK

EXHIBIT "A"

OTHER PROPERTY (Excluding Buildings)

01/07/2026

ESTIMATE OF VALUES

AGRICULTURE AND COMMUNITY CENTER

52	AGRICULTURE EXHIBIT BUILDINGS CONTENTS, 45088 HARRISTON ROAD, FORDWICH, N0G 1V0	11,600
53	ARENA AND COMMUNITY CENTRE CONTENTS, 45088 HARRISTON ROAD, FORDWICH, N0G 1V0	160,900
54	HOCKEY EQUIPMENT AND DASHER BOARDS , 45088 HARRISTON ROAD, FORDWICH, N0G 1V0	31,200
55	2009 OLYMPIA ICE RESURFACER, 45088 HARRISTON ROAD, FORDWICH, N0G 1V0	75,300 SCH ACV
56	PICNIC TABLES, 45088 HARRISTON ROAD, FORDWICH, N0G 1V0	7,500
57	EXMARK MOWER , 45088 HARRISTON ROAD, FORDWICH, N0G 1V0	8,500

BELMORE

58	ARENA/CURLING RINK CONTENTS, 91122 BELMORE LINE, WROXETER, N0G 2X0	341,600
59	SUGAR SHACK CONCESSION BOOTH CONTENTS, 91122 BELMORE LINE, WROXETER, N0G 2X0	4,000
60	PARK PAVILION CONTENTS, 91122 BELMORE LINE, WROXETER, N0G 2X0	2,700

FORDWICH

61	CEMETERY GARDEN TRACTOR, 3010 STATION ROAD, FORDWICH, N0G 1V0	4,700
62	CEMETERY STORAGE CONTENTS, 3010 STATION ROAD, FORDWICH, N0G 1V0	1,200
63	KUBOTA TRACTOR, MOWER, BLOWER, 3017 BROOKHAVEN DRIVE, FORDWICH, N0G 1V0	22,200
64	BALL PARK CANTEEN AND PAVILION CONTENTS, 3084 ALBERT STREET, FORDWICH, N0G 1V0	20,500
65	TRAIL BENCHES, GARBAGE CANS AND PICNIC TABLES	13,200

---

PROPRIETARY DATA : USE OR DISCLOSURE OF THE INFORMATION IN THIS DOCUMENT IS SUBJECT TO THE RESTRICTIONS ON THE TITLE PAGE

CORPORATION OF THE TOWNSHIP OF HOWICK

EXHIBIT "A"

OTHER PROPERTY (Excluding Buildings)

01/07/2026

ESTIMATE OF VALUES

GENERAL

66	MEDIA	500,000
----	-------	---------

GORRIE

67	FIRE HALL CONTENTS AND FIRE-FIGHTING EQUIPMENT, 2005 NELSON STREET NORTH, GORRIE, N0G 1X0	576,600
----	-------------------------------------------------------------------------------------------	---------

68	2008 TG 190 SKID STEER ASLN11247, 2040 RAIL LINE ROAD, GORRIE, N0G 1X0	15,000 SCH ACV
----	------------------------------------------------------------------------	----------------

69	2005 T650 SKID STEER ALG12332 (STEVES LANDSCAPING), 2040 RAIL LINE ROAD, GORRIE, N0G 1X0	50,000 SCH ACV
----	------------------------------------------------------------------------------------------	----------------

70	OPTIMIST POOL PAVILION CONTENT, 2046 JAMES STREET, GORRIE, N0G 1X0	7,500
----	--------------------------------------------------------------------	-------

71	OPTIMISTS POOL CONTENTS, 2046 JAMES STREET, GORRIE, N0G 1X0	17,000
----	-------------------------------------------------------------	--------

72	2023 GARDEN TRACTOR AND 1996 NEW HOLLAND, 2052 ALMA STREET SOUTH, GORRIE, N0G 1X0	14,800
----	-----------------------------------------------------------------------------------	--------

73	CEMETERY STORAGE CONTENTS, 2052 ALMA STREET SOUTH, GORRIE, N0G 1X0	1,200
----	--------------------------------------------------------------------	-------

74	COMMUNITY HALL CONTENTS, 2059 VICTORIA STREET, GORRIE, N0G 1X0	40,600
----	----------------------------------------------------------------	--------

75	GORRIE PARK CONCESSION BOOTH CONTENTS, 2079 ALMA STREET SOUTH, GORRIE, N0G 1X0	7,200
----	--------------------------------------------------------------------------------	-------

76	2021 BOBCAT T66 S/N B4SB18487 , 43739 HARRISTON ROAD , GORRIE, N0G 1X0	93,400
----	------------------------------------------------------------------------	--------

77	* HUSQVARNA TRACTOR YTH2348 S/N 060109A001341 , 43739 HARRISTON ROAD , GORRIE, N0G 1X0	2,500 SCH ACV
----	----------------------------------------------------------------------------------------	---------------

78	LED CHRISTMAS LIGHTS X 95, 89450 MALCOLM LINE, GORRIE, N0G 1X0	78,500
----	----------------------------------------------------------------	--------

79	TRAIL BENCHES, GARBAGE CANS AND PICNIC TABLES	13,200
----	-----------------------------------------------	--------

LANDFILL

80	LANDFILL SHELTER CONTENTS, 45589 HARRISTON ROAD, FORDWICH, N0G 1V0	3,500
----	--------------------------------------------------------------------	-------

---

PROPRIETARY DATA : USE OR DISCLOSURE OF THE INFORMATION IN THIS DOCUMENT IS SUBJECT TO THE RESTRICTIONS ON THE TITLE PAGE

CORPORATION OF THE TOWNSHIP OF HOWICK

EXHIBIT "A"

OTHER PROPERTY (Excluding Buildings)

01/07/2026

ESTIMATE OF VALUES

MUNICIPAL OFFICE AND FUEL DEPOT

81	MUNICIPAL OFFICE CONTENTS, 44816 HARRISTON ROAD, FORDWICH, N0G 1V0	195,200
82	2025 VERMEER DIESEL CHIPPER MODEL NO. BC1000XL, SERIAL NO. 1VRD11AC7S1056625, 44816 HARRISTON ROAD, FORDWICH, N0G 1V0	94,581
83	2023 KUHN MOWER, 44816 HARRISTON ROAD, FORDWICH, N0G 1V0	14,500
84	2017 SWEEPER, 44816 HARRISTON ROAD, FORDWICH, N0G 1V0	9,200 SCH REP
85	EQUIPMENT DEPOT CONTENTS AND TOOLS, 44816 HARRISTON ROAD, FORDWICH, N0G 1V0	596,700
86	1994 CHAMPION 710R GRADER, 44816 HARRISTON ROAD, FORDWICH, N0G 1V0	289,700 SCH ACV
87	2022 150JOY-BR MOTORGRADER WITH X SLOPE S/N EB400478 , 44816 HARRISTON ROAD, FORDWICH, N0G 1V0	458,400
88 *	2020 CAT BACKHOE/LOADER & AUGER MODEL 420XE , 44816 HARRISTON ROAD, FORDWICH, N0G 1V0	172,900 SCH REP
89	2012 CATERILLAR MOTOR GRADER, MODEL NO. 140M AWD, SERIAL NO. CAT0140MKD9G01324, 44816 HARRISTON ROAD, FORDWICH, N0G 1V0	367,800 SCH REP
90	COMMUNICATION EQUIPMENT, 44816 HARRISTON ROAD, FORDWICH, N0G 1V0	33,100
91	2013 KUBOTA TRACTOR MODEL MU06X & LOADER MODEL M4L, 44816 HARRISTON ROAD, FORDWICH, N0G 1V0	83,400 SCH REP
92	2018 CATERPILAR GRADER , SERIAL NO. N9J00P36, 44816 HARRISTON ROAD, FORDWICH, N0G 1V0	451,000 SCH REP
93	2013 SNOW BLOWER, 44816 HARRISTON ROAD, FORDWICH, N0G 1V0	4,700 SCH REP
94	2024 KUBOTA TRACTOR BX2380 SERIAL NO. H73699 WITH ATTACHMENTS, 44816 HARRISTON ROAD, FORDWICH, N0G 1V0	38,100

---

PROPRIETARY DATA : USE OR DISCLOSURE OF THE INFORMATION IN THIS DOCUMENT IS SUBJECT TO THE RESTRICTIONS ON THE TITLE PAGE

CORPORATION OF THE TOWNSHIP OF HOWICK

EXHIBIT "A"

OTHER PROPERTY (Excluding Buildings)

01/07/2026

ESTIMATE OF VALUES

WROXETER

95	BALL PARK PAVILION AND BOOTH CONTENTS, 1020 MARRIETTA STREET, WROXETER, N0G 2X0	14,800
96	BALL PARK STORAGE CONTENTS, 1020 MARRIETTA STREET, WROXETER, N0G 2X0	1,200
97	WROXETER COMMUNITY HALL CONTENTS, 1094 CENTRE STREET, WROXETER, N0G 2X0	67,600
98	CEMETERY STORAGE CONTENTS, 43172 HIGHWAY 87, WROXETER, N0G 2X0	1,200
99	TRAIL BENCHES, GARBAGE CANS AND PICNIC TABLES	13,200

---

**TOTALS:**

<u>BLANKET</u>	<u>SPECIFIED</u>
3,511,881	1,521,500

---

PROPRIETARY DATA : USE OR DISCLOSURE OF THE INFORMATION IN THIS DOCUMENT IS SUBJECT TO THE RESTRICTIONS ON THE TITLE PAGE

## EXHIBIT 'B'

## AUTOMOBILE FLEET SCHEDULE

## BUILDING

1	24	JEEP COMPASS	112389
---	----	--------------	--------

## DRAINS

2	18	CF MOTO U FORCE 800 EFI	600011
---	----	-------------------------	--------

## FIRE

3	00	FREIGHTLINER FIRE TRUCK	B12987
4	20	FREIGHTLINER TANKER TRUCK	LT3391
5	00	INTERNATIONAL FIRE PUMP TRUCK	B12987
6	14	DODGE RAM 1500	262388
7	12	FORD EXPEDITION	F05846
8	24	BEAR UTILITY TRAILER	301624
9	07	SURREY FIRE SAFETY TRAILER	217713
10	11	FORD ECONOLINE E350	A00129

## RECREATION

11	07	FORD F150	A02631
----	----	-----------	--------

## ROADS

12	19	FORD F150	C37065
13	20	FORD F150	D20989
14	08	INTERNATIONAL TANDEM DUMP	687400
15	15	FORD F450	D01813
16	20	INTERNATIONAL SNOW PLOW	687219
17	21	BEAR LANDSCAPE TRAILER	103358
18	05	FORD STIRLING SNOWPLOW (LEASED)	H87455
19	26	RAM 5500 BIG HORN	171725
20	26	CTC ENCLOSED TRAILER	315137

ADMINISTRATION SHOULD CAREFULLY EXAMINE THIS SCHEDULE TO DETERMINE ACCURATE INFORMATION. ANY CHANGES OR DISCREPANCIES SHOULD BE REPORTED TO US.

# Staff Report to Council

---

**Report From:** Amy Van Meeteren, Treasurer/Manager of Finance

**Meeting Date:** June 16, 2026

**Report:** FIN-2026-17  
 May 13 to June 11, 2026 Accounts Payable

---

**Recommendation:**

**That the Council of the Township of Howick receive report FIN-2026-15, May 13 to June 11, 2026 Accounts Payable, for information only.**

**Report Overview**

<b>Purpose of Report</b>	For Information
<b>Council Priority Alignment</b>	Safe & Reliable Infrastructure Welcoming & Vibrant Community Inviting Neighbourhoods & Thriving Businesses People First
<b>Consultations</b>	None
<b>Attachment(s) to Report</b>	Accounts Payable May 13 to June 11, 2026

**Context and Background**

To update Council on the Accounts Payable Report for the period of May 13 to June 11, 2026 in the amount of \$1,625,765.79.

## Linkages

- [Accounts Payable May 13 to June 11, 2026](#)
- 

**Respectfully submitted,**

**Amy Van Meeteren, Treasurer/Manager of Finance**

# Accounts Payable

Bills and Accounts May 13 - Jun 11 2026

Vendor 000000 Through 999999

Invoice Entry Date 2026-05-13 to 2026-06-11 Paid Invoices Cheque Date 2026-05-13 to 2026-06-11

Vendor Number	Vendor Name	Invoice Number	Invoice Desc	Chq Nbr	Invoice Date	Entry Date	Amount
001050	1-800-BOARDUP	2296880	EMERGENCY BOARD UP - WROX	025160	2026-05-19	2026-05-19	5,264.60
			01-2400-2404-12810 EMERGENCY BOARD UP - WROX				5,264.60
001708	A.J. STONE	200514	O-RING NITRILE BLACK	025207	2026-06-10	2026-06-10	190.41
			01-2100-2101-50554 O-RING NITRILE BLACK				190.41
001015	AARON HARDING	MAY 28/26	ENTRANCE PERMIT REF	025181	2026-05-28	2026-05-28	100.00
			01-3900-3970-43300 ENTRANCE PERMIT REF				100.00
001309	ALTRUCK INTERNATIONAL TR60055421		DUST SHEILD/PLC/TUBE	025208	2026-06-10	2026-06-10	475.14
			01-3800-3811-50553 DUST SHEILD/PLC/TUBE				475.14
001309	ALTRUCK INTERNATIONAL TR60055421X1		PLC UNION CONNECTION	025208	2026-06-10	2026-06-10	28.48
			01-3800-3811-50553 PLC UNION CONNECTION				28.48
001553	AUDREY BRIDGE	05 26 2026	TRAINING LUNCH	025209	2026-06-10	2026-06-10	185.00
			01-2900-0000-50103 TRAINING LUNCH				185.00
001051	AVON MAITLAND DISTRICT SC JUNE 2026		JUNE 2026 INSTALLMENT	025210	2026-06-10	2026-06-10	218,534.91
			01-9500-0000-79500 JUNE 2026 INSTALLMENT				218,534.91
001105	B.M. ROSS AND ASSOCIATES 31138		BRIDGE #11 ENGINEERING	025182	2026-05-28	2026-05-28	3,150.98
			01-3500-9019-90000 BRIDGE #11 ENGINEERING				3,150.98
001105	B.M. ROSS AND ASSOCIATES 31139		CULVERT #29 ENGINEERING	025182	2026-05-28	2026-05-28	2,174.34
			01-3500-9018-90000 CULVERT #29 ENGINEERING				2,174.34
001053	BELL MOBILITY	527167077 MAY 21/26	CELL PHONES	002017	2026-05-29	2026-05-29	339.37
			01-3900-3901-50530 5192910879				23.91
			01-7100-7101-50530 5192917106				27.33
			01-2100-2101-50530 FIRE TABLET 2				18.42
			01-2400-2401-50530 5192917732				24.94
			01-2100-2101-50530 FIRE TABLET 1				18.42
			01-2100-2101-50530 5193570847				18.42
			01-2100-2101-50530 5193575825				27.33
			01-3900-3901-50530 5193576834				23.79
			01-3900-3901-50530 5193576845				18.42
			01-3900-3901-50530 5193577394				24.15
			01-3900-3901-50530 5193577531				23.98
			01-3900-3901-50530 5193578031				23.79
			01-2100-2101-50530 5193578451				27.33
			01-2100-2101-50530 FIRE TABLET 4				18.42
			01-2100-2101-50530 FIRE TABLET 3				20.72
001145	BELMORE COMMUNITY CENT MAY 13/26		DON- ESTATE OF EDWIN HOFMANN	025161	2026-05-19	2026-05-19	10,000.00
			01-0000-0000-57100 DON- ESTATE OF EDWIN HOFMANN				10,000.00

# Accounts Payable

Bills and Accounts May 13 - Jun 11 2026

Vendor 000000 Through 999999

Invoice Entry Date 2026-05-13 to 2026-06-11 Paid Invoices Cheque Date 2026-05-13 to 2026-06-11

Vendor Number	Vendor Name	Invoice Number	Invoice Desc	Chq Nbr	Invoice Date	Entry Date	Amount
001145	BELMORE COMMUNITY CENT	MAR 30/26	DONATION - ARENA BOARDS	025161	2026-05-19	2026-05-19	5,000.00
			01-0000-0000-57100				5,000.00
						Vendor Total	15,000.00
001251	BILL MILLER	44331	BOLTS/NUTS & WASHERS	025183	2026-05-28	2026-05-28	78.83
			LAWNSIGNS				
			01-9200-0000-50555				78.83
001189	BRANDT SECURITY PAP	21-10817	MONTHLY ALARM	002013	2026-05-22	2026-05-22	45.20
			01-1300-0000-50556				22.60
			01-3800-3850-50551				22.60
001792	CANADA'S FINEST COFFEE	IN014307	COFFEE	025211	2026-06-10	2026-06-10	93.00
			01-2100-2101-50103				93.00
001393	CEDAR SIGNS	2026/1706	NO DUMPING SIGN	025162	2026-05-19	2026-05-19	202.47
			01-2400-2404-50555				202.47
001056	CIBC VISA	MAR 30/26	CITATION C CITATION CANADA-HR DOWNLOADS	002016	2026-05-25	2026-05-25	794.64
			01-7100-7102-50205				397.32
			01-1300-0000-50205				397.32
001056	CIBC VISA	APR 1/26	ZOOM.COM ZOOM MEMBERSHIP 2026	002016	2026-05-25	2026-05-25	242.84
			01-1300-0000-50250				242.84
001056	CIBC VISA	APR 14/26	LY SPORTS LIFE GUARD SWIM SUITS	002016	2026-05-25	2026-05-25	406.74
			01-7100-7102-50205				406.74
001056	CIBC VISA	APR 14/26	WORKSITES JHSC SAFETY ONLINE PT 1-B ROPP	002016	2026-05-25	2026-05-25	337.87
			01-7100-7101-50103				337.87
001056	CIBC VISA	MAR 25/26	AMZN PORTABLE POWER CABLES RETURN	002016	2026-05-25	2026-05-25	-239.54
			01-2100-2101-50553				-239.54
001056	CIBC VISA	MAR 28/26	LA TINOZ LUNCH TRNING COUNTY	002016	2026-05-25	2026-05-25	186.86
			01-2100-2101-12810				186.86
001056	CIBC VISA	MAR 28/26	ULTRAMAR FUEL - CAR 2- 116.62L @ 1.609	002016	2026-05-25	2026-05-25	187.64
			01-2100-2111-50510				187.64
001056	CIBC VISA	MAR 28/26	TIM'S COUNTY TRAINING BREAKFAST	002016	2026-05-25	2026-05-25	45.18
			01-2100-2101-12810				45.18
001056	CIBC VISA	MAR 28/26	BLTYH FD N COUNTY TRANING LUNCH BLYTH FM	002016	2026-05-25	2026-05-25	112.52
			01-2100-2101-12810				112.52
001056	CIBC VISA	MAR 29/26	TIM'S COUNTY TRAINING LUNCH-TIMS	002016	2026-05-25	2026-05-25	552.83
			01-2100-2101-12810				552.83
001056	CIBC VISA	APR 4/26	GOV DEEALS RADIO UPGRADE	002016	2026-05-25	2026-05-25	4,016.95
			01-2100-2101-90000				4,016.95
001056	CIBC VISA	APR 4/26	CANADIAN TIBLDG UPGRADES-STORAGE CABINET	002016	2026-05-25	2026-05-25	438.24
			01-2100-2101-90002				438.24

# Accounts Payable

Bills and Accounts May 13 - Jun 11 2026

Vendor 000000 Through 999999

Invoice Entry Date 2026-05-13 to 2026-06-11 Paid Invoices Cheque Date 2026-05-13 to 2026-06-11

Vendor Number	Vendor Name	Invoice Number	Invoice Desc	Chq Nbr	Invoice Date	Entry Date	Amount
001056	CIBC VISA	APR 4/26	CANADN TIRI BLDG UPGRADES-STORAGE CABINET	002016	2026-05-25	2026-05-25	237.29
			01-2100-2101-90002 BLDG UPGRADES-STORAGE CABINET				237.29
001056	CIBC VISA	APR 9/26	FOGALS WATER BOTTLES	002016	2026-05-25	2026-05-25	35.00
			01-2100-2101-50103 WATER BOTTLES				35.00
001056	CIBC VISA	APR 10/26	BLYTH INN RADIO MEETING - J KESTNER	002016	2026-05-25	2026-05-25	22.28
			01-2100-2101-50103 RADIO MEETING - J KESTNER				22.28
001056	CIBC VISA	APR 16/26	GOV DEALS CUSTOM PENETRATING NOZZLES	002016	2026-05-25	2026-05-25	183.98
			01-2100-2101-50103 CUSTOM PENETRATING NOZZLES				183.98
001056	CIBC VISA	APR 17/26	AMZN HEADPHONE SPLITTER	002016	2026-05-25	2026-05-25	39.59
			01-2100-2101-50553 HEADPHONE SPLITTER				39.59
001056	CIBC VISA	APR 17/26	AMZN 2 COMMUNICATION SPEAKER	002016	2026-05-25	2026-05-25	40.43
			01-2100-2101-50553 COMMUNICATION SPEAKER				40.43
001056	CIBC VISA	APR 17/26	ADOBE ADOBE MONTHLY MEMBERSHIP	002016	2026-05-25	2026-05-25	45.18
			01-2100-2101-50556 ADOBE MONTHLY MEMBERSHIP				45.18
001056	CIBC VISA	APR 17/26	CANADN TIF HITCH/SAFETY TAPE/ REUSABLE BA	002016	2026-05-25	2026-05-25	171.47
			01-2100-2101-50553 HITCH/SAFETY TAPE/ REUSABLE BA				171.47
001056	CIBC VISA	APR 19/26	AMZN COMMUNICATION SPEAKER	002016	2026-05-25	2026-05-25	25.53
			01-2100-2101-50553 COMMUNICATION SPEAKER				25.53
001056	CIBC VISA	APR 19/26	AMZN 2 CAR STEERING WHEEL DESK	002016	2026-05-25	2026-05-25	103.29
			01-2100-2101-50200 CAR STEERING WHEEL DESK				103.29
001056	CIBC VISA	APR 20/26	GOV DEALS LIGHT CAUTION SIGN	002016	2026-05-25	2026-05-25	61.33
			01-2100-2101-50553 LIGHT CAUTION SIGN				61.33
001056	CIBC VISA	APR 20/26	MEM DON DONATION M.ROSS	002016	2026-05-25	2026-05-25	51.50
			01-1100-0000-51500 DONATION M.ROSS				51.50
001056	CIBC VISA	APR 21/26	HRT&STROI MEM DONATION- S.ROSS	002016	2026-05-25	2026-05-25	51.50
			01-1100-0000-51500 MEM DONATION- S.ROSS				51.50
001056	CIBC VISA	APR 22/26	AMZN WOODEN HANGERS	002016	2026-05-25	2026-05-25	31.57
			01-2100-2101-50553 WOODEN HANGERS				31.57
001056	CIBC VISA	APR 24/26	AMZN BEACH SANDTOYS	002016	2026-05-25	2026-05-25	37.28
			01-7100-7102-50555 BEACH SANDTOYS				37.28
001056	CIBC VISA	APR 24/26	AMZN 2 METAL DETECTOR	002016	2026-05-25	2026-05-25	101.69
			01-7300-0000-50555 METAL DETECTOR				101.69
001056	CIBC VISA	MAR 25/26	SGS WATER TESTING	002016	2026-05-25	2026-05-25	610.20
			01-4200-0000-50556 WATER TESTING				610.20
001056	CIBC VISA	APR 2/26	AMZN LCD MONITOR	002016	2026-05-25	2026-05-25	192.87
			01-1300-0000-50200 LCD MONITOR				192.87
001056	CIBC VISA	APR 7/26	INSTA CART B&A SCHOOL FOOD	002016	2026-05-25	2026-05-25	286.10
			01-7200-7201-50550 B&A SCHOOL FOOD				286.10
001056	CIBC VISA	APR 8/26	HIGH FIVE HEALTHY CHLD DEV CRSE-6 PPL	002016	2026-05-25	2026-05-25	508.50
			01-7100-7102-50102 HEALTHY CHLD DEV CRSE-6 PPL				508.50

# Accounts Payable

Bills and Accounts May 13 - Jun 11 2026

Vendor 000000 Through 999999

Invoice Entry Date 2026-05-13 to 2026-06-11 Paid Invoices Cheque Date 2026-05-13 to 2026-06-11

Vendor Number	Vendor Name	Invoice Number	Invoice Desc	Chq Nbr	Invoice Date	Entry Date	Amount
Vendor Total							9,919.35
001009	COUNTY OF HURON	JUNE 2026	JUNE 2026 INSTALLMENT	025212	2026-06-10	2026-06-10	729,341.00
			01-9100-0000-79100		JUNE 2026 INSTALLMENT		729,341.00
001394	D & M AUTO SERVICE	11494	P-20 OIL CHANGE & CHECK	025163	2026-05-19	2026-05-19	103.96
			01-3800-3812-50554		P-20 OIL CHANGE & CHECK		103.96
001186	DA-LEE DUST CONTROL	106733	35% CALCIUM-25,270L@0.300/L	025213	2026-06-10	2026-06-10	9,244.53
			01-3300-3304-50656		35% CALCIUM-25,270L@0.300/L		9,244.53
001186	DA-LEE DUST CONTROL	106366	35% CALCIUM-25,270L@0.300/L	025213	2026-06-10	2026-06-10	9,244.53
			01-3300-3304-50656		35% CALCIUM-25,270L@0.300/L		9,244.53
001186	DA-LEE DUST CONTROL	106456	35% CALCIUM-25,270L@0.300/L	025213	2026-06-10	2026-06-10	9,244.53
			01-3300-3304-50656		35% CALCIUM-25,270L@0.300/L		9,244.53
001186	DA-LEE DUST CONTROL	106524	35% CALCIUM-25,270L@0.300/L	025213	2026-06-10	2026-06-10	9,244.53
			01-3300-3304-50656		35% CALCIUM-25,270L@0.300/L		9,244.53
001186	DA-LEE DUST CONTROL	106587	35% CALCIUM-25,270L@0.300/L	025213	2026-06-10	2026-06-10	9,244.53
			01-3300-3304-50656		35% CALCIUM-25,270L@0.300/L		9,244.53
001186	DA-LEE DUST CONTROL	106912	35% CALCIUM-25,270L@0.300/L	025213	2026-06-10	2026-06-10	9,244.53
			01-3300-3304-50656		35% CALCIUM-25,270L@0.300/L		9,244.53
001186	DA-LEE DUST CONTROL	106853	35% CALCIUM-25,270L@0.300/L	025213	2026-06-10	2026-06-10	9,244.53
			01-3300-3304-50656		35% CALCIUM-25,270L@0.300/L		9,244.53
001186	DA-LEE DUST CONTROL	105921	35% CALCIUM-25,270L@0.300/L	025213	2026-06-10	2026-06-10	9,244.53
			01-3300-3304-50656		35% CALCIUM-25,270L@0.300/L		9,244.53
001186	DA-LEE DUST CONTROL	106004	35% CALCIUM-25,270L@0.300/L	025213	2026-06-10	2026-06-10	9,244.53
			01-3300-3304-50656		35% CALCIUM-25,270L@0.300/L		9,244.53
001186	DA-LEE DUST CONTROL	106045	35% CALCIUM-25,270L@0.300/L	025213	2026-06-10	2026-06-10	9,244.53
			01-3300-3304-50656		35% CALCIUM-25,270L@0.300/L		9,244.53
001186	DA-LEE DUST CONTROL	106047	35% CALCIUM-25,270L@0.300/L	025213	2026-06-10	2026-06-10	9,244.53
			01-3300-3304-50656		35% CALCIUM-25,270L@0.300/L		9,244.53
001186	DA-LEE DUST CONTROL	106123	35% CALCIUM-25,700L@0.300/L	025213	2026-06-10	2026-06-10	8,712.30
			01-3300-3304-50656		35% CALCIUM-25,700L@0.300/L		8,712.30
001186	DA-LEE DUST CONTROL	106143	35% CALCIUM-25,270L@0.300/L	025213	2026-06-10	2026-06-10	9,244.53
			01-3300-3304-50656		35% CALCIUM-25,270L@0.300/L		9,244.53
001186	DA-LEE DUST CONTROL	106248	35% CALCIUM-25,270L@0.300/L	025213	2026-06-10	2026-06-10	9,244.53
			01-3300-3304-50656		35% CALCIUM-25,270L@0.300/L		9,244.53
001186	DA-LEE DUST CONTROL	106259	35% CALCIUM-25,270L@0.300/L	025213	2026-06-10	2026-06-10	9,244.53
			01-3300-3304-50656		35% CALCIUM-25,270L@0.300/L		9,244.53
001186	DA-LEE DUST CONTROL	106322	35% CALCIUM-25,270L@0.300/L	025213	2026-06-10	2026-06-10	9,244.53

# Accounts Payable

Bills and Accounts May 13 - Jun 11 2026

Vendor 000000 Through 999999

Invoice Entry Date 2026-05-13 to 2026-06-11 Paid Invoices Cheque Date 2026-05-13 to 2026-06-11

Vendor Number	Vendor Name	Invoice Number	Invoice Desc	Chq Nbr	Invoice Date	Entry Date	Amount
			01-3300-3304-50656	35% CALCIUM-25,270L@0.300/L			9,244.53
Vendor Total							147,380.25
001050	DEREK BROSS	MAY 28/26	WORK BOOT REIMBURS	025184	2026-05-28	2026-05-28	250.00
			01-3900-3901-50204	WORK BOOT REIMBURS			250.00
001904	DJ'S HANDCRAFTED SOLID W 3805		BG BD WALK/WALKWAY PLANTERS	025164	2026-05-19	2026-05-19	6,678.30
			01-7100-7101-90000	BG BOARDWALK PLANTER X 21			3,749.34
			01-7100-7101-90000	BG WALKWAY PLANTER X 24			2,928.96
001241	DONNELLY & MURPHY	14745	1083 CENTRE ST LEGAL	025185	2026-05-28	2026-05-28	1,681.22
			01-2400-2404-51010	1083 CENTRE ST LEGAL			1,681.22
001241	DONNELLY & MURPHY	1431	HOWICK P/F NEABLE LEGAL	025214	2026-06-10	2026-06-10	1,800.06
			01-1100-0000-90000	HOWICK P/F NEABLE LEGAL			1,800.06
Vendor Total							3,481.28
001969	DOUGLAS R ARMSTRONG TR.38801		16X8 OFFICE - LANDFILL	025215	2026-06-10	2026-06-10	395.50
			01-4300-0000-50556	16X8 OFFICE - LANDFILL			395.50
002006	EPIC RACEWEAR ONEPROMC 7078830		ST BANNER POLES & BRACKETS	025216	2026-06-10	2026-06-10	689.10
			01-8100-0000-50557	ST BANNER POLES & BRACKETS			689.10
001764	EQUITABLE LIFE OF CANADA JUNE 2026		JUNE 2026 BENEFITS	002018	2026-06-03	2026-06-03	9,982.35
			01-1300-0000-50102	JUNE 2026 BENEFITS			3,030.67
			01-2400-2401-50102	JUNE 2026 BENEFITS			548.70
			01-3900-3901-50102	JUNE 2026 BENEFITS			3,870.96
			01-7100-7101-50102	JUNE 2026 BENEFITS			1,440.01
			01-2100-2101-50102	JUNE 2026 BENEFITS			1,092.01
001944	FISHER'S REGALIA & UNIFORMS 58818		ENGRAVED BADGES	025217	2026-06-10	2026-06-10	128.84
			01-2100-2101-50553	ENGRAVED BADGES			128.84
001444	FORDWICH PARKS BOARD	05 28 2026	DUCK RACE REVENUE	025186	2026-05-28	2026-05-28	300.00
			01-0000-0000-57100	DUCK RACE REVENUE			300.00
001109	FORDWICH TIRE LTD	REP015288	BACKHOE BOOT REPAIR	025187	2026-05-28	2026-05-28	127.69
			01-3800-3831-50554	BACKHOE BOOT REPAIR			127.69
002026	FORT 44 INC	4272	IT SERVICES JUNE 2026	025218	2026-06-10	2026-06-10	3,326.53
			01-1300-0000-50250	IT SERVICES JUNE 2026			3,326.53
001781	FOSTER'S PLUMBING & HEATING 1077		POOL MTCE - TURN WATER ON	025165	2026-05-19	2026-05-19	295.40
			01-7100-7102-50556	POOL MTCE - TURN WATER ON			295.40
001350	FRANCOTYP-POSTALIA CANADIC 26018876		POST BASE/RATE CHANGE	025219	2026-06-10	2026-06-10	101.70
			01-1300-0000-50210	POST BASE/RATE CHANGE			101.70

# Accounts Payable

Bills and Accounts May 13 - Jun 11 2026

Vendor 000000 Through 999999

Invoice Entry Date 2026-05-13 to 2026-06-11 Paid Invoices Cheque Date 2026-05-13 to 2026-06-11

Vendor Number	Vendor Name	Invoice Number	Invoice Desc	Chq Nbr	Invoice Date	Entry Date	Amount
001824	FREIBURGER WELDING & MA	173705	HEX CAPS C18 & C12	025188	2026-05-28	2026-05-28	553.93
			01-3800-3818-50554				276.97
			01-3800-3824-50554				276.96
001259	GEI CONSULTANTS	730020438B	BOWMAN SUBDIVISION PLANNING	025166	2026-05-19	2026-05-19	64.97
			01-8100-0000-12810				64.97
001259	GEI CONSULTANTS	730021030	BOWMAN SUBDIVISION PLANNING	025166	2026-05-19	2026-05-19	807.95
			01-8100-0000-12810				807.95
Vendor Total							872.92
001281	GEORGIAN BAY FIRE & SAFE	1108834	EXTINGUISHER INSPECTION	025189	2026-05-28	2026-05-28	662.64
			01-2100-2101-50554				662.64
001281	GEORGIAN BAY FIRE & SAFE	1108830	ANNUAL INSPECTION	025220	2026-06-10	2026-06-10	3,074.06
			01-7100-7101-50555				3,074.06
Vendor Total							3,736.70
001333	GLOBAL PAYMENTS PAP	043026	DEBIT CHARGES- APRIL 2026	002014	2026-05-22	2026-05-22	48.54
			01-1300-0000-50220				24.27
			01-7100-7101-50556				24.27
001379	HOWICK AGRICULTURAL SOC	2026 APR - PROFIT	PROFIT SHARE	025167	2026-05-19	2026-05-19	71.47
			01-7100-7101-57100				71.47
001994	HOWICK HOMECOMING	05 19 2026	DONATIONS	025168	2026-05-19	2026-05-19	6,250.00
			01-0000-0000-57100				6,250.00
001994	HOWICK HOMECOMING	05 13 2026	DONATIONS	025168	2026-05-19	2026-05-19	8,300.00
			01-0000-0000-57100				8,300.00
001994	HOWICK HOMECOMING	05 28 2026	DONATION FROM FAMILY FEST COMM	025190	2026-05-28	2026-05-28	3,725.98
			01-1100-0000-51500				3,725.98
001994	HOWICK HOMECOMING	05 29 2026	DONATIONS	025190	2026-05-28	2026-05-28	3,200.00
			01-0000-0000-57100				3,200.00
001994	HOWICK HOMECOMING	06 09 2026	DECORATIVE VINYL ROLLS	025221	2026-06-10	2026-06-10	75.00
			01-2100-2101-50250				75.00
001994	HOWICK HOMECOMING	06 10 2026	HOMECOMING VINYL ROLLS	025221	2026-06-10	2026-06-10	150.00
			01-1300-0000-50555				150.00
Vendor Total							21,700.98
001785	HOWICK OPTIMIST CLUB	05 28 2026	DONATION FROM FAMILY FEST COMM	025191	2026-05-28	2026-05-28	1,000.00
			01-1100-0000-51500				1,000.00
001052	HURON-PERTH COUNTY ROM	JUNE 2026	JUNE 2026 INSTALMENT	025222	2026-06-10	2026-06-10	11,944.44
			01-9600-0000-79600				11,944.44

# Accounts Payable

Bills and Accounts May 13 - Jun 11 2026

Vendor 000000 Through 999999

Invoice Entry Date 2026-05-13 to 2026-06-11 Paid Invoices Cheque Date 2026-05-13 to 2026-06-11

Vendor Number	Vendor Name	Invoice Number	Invoice Desc	Chq Nbr	Invoice Date	Entry Date	Amount
001288	HUTCHISON WELDING (2022)	11365	NEW SIGN POSTS/WELCOME SIGNS	025192	2026-05-28	2026-05-28	2,220.45
			01-9200-0000-50556 NEW SIGN POSTS/WELCOME SIGNS				2,220.45
001575	HV POWER	4118	BOOM TRUCK/DAM INSTALL	025193	2026-05-28	2026-05-28	565.00
			01-9400-0000-50558 BOOM TRUCK/DAM INSTALL				565.00
001298	HYDRO ONE NETWORKS INC	APR 2026	APR 2026 USAGE	002019	2026-06-03	2026-06-03	11,866.40
			01-9400-0000-50500 APR 2026 USAGE				46.62
			01-1300-0000-50500 APR 2026 USAGE				262.95
			01-3900-3901-50500 APR 2026 USAGE				305.39
			01-9400-0000-50500 APR 2026 USAGE				29.88
			01-7100-7102-50500 APR 2026 USAGE				41.63
			01-2100-2101-50500 APR 2026 USAGE				306.21
			01-7100-7101-50500 APR 2026 USAGE				9,047.62
			01-9300-0000-50500 APR 2026 USAGE				32.00
			01-9400-0000-50500 APR 2026 USAGE				69.40
			01-9400-0000-50500 APR 2026 USAGE				518.23
			01-9300-0000-50500 APR 2026 USAGE				567.90
			01-9000-0000-50500 APR 2026 USAGE				45.39
			01-8900-0000-50500 APR 2026 USAGE				14.80
			01-9200-0000-50500 APR 2026 USAGE				480.52
			01-9400-0000-50500 APR 2026 USAGE				36.84
			01-9400-0000-50500 APR 2026 USAGE				7.72
			01-9300-0000-50500 APR 2026 USAGE				6.61
			01-9200-0000-50500 APR 2026 USAGE				10.04
			01-9400-0000-50500 APR 2026 USAGE				7.72
			01-4300-0000-50500 APR 2026 USAGE				28.93
001171	J. STEWART ELECTRIC	05 01 2026	FH- RELOCATE LIGHTS/POT LGHTS	025169	2026-05-19	2026-05-19	3,827.93
			01-2100-2101-50554 FH- RELOCATE LIGHTS/POT LGHTS				3,827.93
002038	JESSE KOEHLER	VOUC 546/26	MAY- RIBBONS/EQUIP/REMOVAL	025223	2026-06-10	2026-06-10	2,465.75
			01-9400-0000-50556 MAY-RIBBONS/EQUIP/REMOVAL				2,465.75
002038	JESSE KOEHLER	VOUC 547/26	DAM SUPPLIES	025223	2026-06-10	2026-06-10	40.00
			01-9400-0000-50557 DAM SUPPLIES				40.00
002038	JESSE KOEHLER	VOUC 548/26	FLOWERS/SHRUBS/EQUIP	025223	2026-06-10	2026-06-10	3,356.09
			01-9400-0000-50556 FLOWERS/SHRUBS/EQUIP				3,356.09
Vendor Total							5,861.84
002027	JOE JOHNSON EQUIPMENT	5493	REMOTE CHARGER	025170	2026-05-19	2026-05-19	47.91
			01-3800-3815-50554 REMOTE CHARGER				47.91
001050	JONATHAN FERRIER	05 28 2026	DUP TAX PAYMENT REIMBURSMNT	025194	2026-05-28	2026-05-28	1,127.00
			01-0000-0000-12811 DUP TAX PAYMENT REIMBURSMNT				1,127.00

# Accounts Payable

Bills and Accounts May 13 - Jun 11 2026

Vendor 000000 Through 999999

Invoice Entry Date 2026-05-13 to 2026-06-11 Paid Invoices Cheque Date 2026-05-13 to 2026-06-11

Vendor Number	Vendor Name	Invoice Number	Invoice Desc	Chq Nbr	Invoice Date	Entry Date	Amount
001050	JORDAN MURRAY	05 19 2026	WORK BOOTS	025171	2026-05-19	2026-05-19	250.00
			01-3900-3901-50204 WORK BOOTS				250.00
001490	JOSH KESTNER	05 29 2026	DZ MEDICAL REIMBURSMENT	025195	2026-05-28	2026-05-28	100.00
			01-2100-2101-50103 DZ MEDICAL REIMBURSMENT				100.00
001490	JOSH KESTNER	06 09 2026	PARTS/MOUNTS/ELECT FOR TRUCK	025224	2026-06-10	2026-06-10	853.52
			01-2100-2106-50553 LADDER BRACKET				38.32
			01-2100-2101-50553 LED LIGHTHEAD				60.24
			01-2100-2101-50553 PLASTIC CHROME FLANGE				6.03
			01-2100-2101-50553 LED CHROME WARNING LIGHT				53.32
			01-2100-2101-50553 SERIES FLANGE CHROME LIGHT				7.18
			01-2100-2101-50553 STAR WARNING				7.18
			01-2100-2106-50553 WHELEN STRIP LITE PLUS XL				60.24
			01-2100-2101-50553 WHELEN TIR LED				4.87
			01-2100-2106-50553 WHELEN 904BTT				61.39
			01-2100-2101-50553 WHELEN 6" ROUND LED LIGHT				32.56
			01-2100-2101-50553 WHELEN 600 SERIES LIGHT				10.64
			01-2100-2110-50553 SEN CH 2 COMBINATION				26.79
			01-2100-2103-50553 FIRE SER MOUNTING PLATE				83.30
			01-2100-2103-50553 SOUTH PARK CAST METAL COVER				26.79
			01-2100-2110-50553 METAL SAW BRACKET				26.79
			01-2100-2101-50553 BUMPER MOUNTING BRACKET				4.87
			01-2100-2101-50553 AUTO REPLACEMENT PARTS				4.87
			01-2100-2103-50553 ELECT VERNIER THROTTLE				4.87
			01-2100-2101-50553 ANSUL PORT FIRE EXTINGUISHER				6.03
			01-2100-2101-50250 ACOUSTIC PRESENT PANELS				14.10
			01-2100-2101-50200 WIRE STORAGE SHELF				4.86
			01-2100-2101-50200 OXYGEN TANK BAGS				4.86
			01-2100-2104-50553 HEAVY DUTY CAST WHEEL CHOCKS				119.05
			01-2100-2101-50553 MOUNT LIGHT BAR BRACKET				8.32
			01-2100-2101-50553 TAIL LAMP KIT				10.63
			01-2100-2101-50103 SS OXYGEN TANK HOLDERS X2				16.40
			01-2100-2101-50250 METAL BROCHURE DISPLAY				18.82
			01-2100-2101-50553 SMART LED STROBE LIGHT				42.93
			01-2100-2101-50103 BLACK ROLLING DOLLIES				68.30
			01-2100-2101-50553 FIRE EXTINGUISHERS				6.02
			01-2100-2101-50103 REAL GEAR BAR CLAMPS				12.95
Vendor Total							953.52
001433	KEN ROBINSON REFRIGERAT 59343		HCC- NO HEAT REPAIR	025172	2026-05-19	2026-05-19	663.88
			01-7100-7101-50556 HCC- NO HEAT REPAIR				663.88
001243	KEVIN DOIG	VOUC 542/26	DAM INSTALL & HALL	025173	2026-05-19	2026-05-19	299.10
			01-9400-0000-50557 DAM INSTALL & HALL				299.10
001243	KEVIN DOIG	VOUC 544/26	EMANUEL MARTIN TREE @ HARBOUR	025196	2026-05-28	2026-05-28	339.00

# Accounts Payable

Bills and Accounts May 13 - Jun 11 2026

Vendor 000000 Through 999999

Invoice Entry Date 2026-05-13 to 2026-06-11 Paid Invoices Cheque Date 2026-05-13 to 2026-06-11

Vendor Number	Vendor Name	Invoice Number	Invoice Desc	Chq Nbr	Invoice Date	Entry Date	Amount
001243	KEVIN DOIG	VOUC 550/26	01-9400-0000-50557 EMANUEL MARTIN TREE @ HARBOUR				339.00
			POTTING SOIL	025225	2026-06-10	2026-06-10	98.31
			BRIDGE/BOXES				
			01-9400-0000-50557 POTTING SOIL BRIDGE/BOXES				98.31
						Vendor Total	736.41
002042	LENOVO (CANADA) INC	N100132303	BY-LAW COMPUTER	025226	2026-06-10	2026-06-10	1,771.19
			01-2400-2404-90000 BY-LAW COMPUTER				1,771.19
002042	LENOVO (CANADA) INC	N100132545	BYLAW COMP/BUILDING	025226	2026-06-10	2026-06-10	170.64
			COMP				
			01-2400-2401-90000 BUILDING COMPUTER WEBCAM				87.91
			01-2400-2404-90000 BY-LAW COMPUTER WEBCAM				82.73
002042	LENOVO (CANADA) INC	N100133221	BUILDING COMPUTER	025226	2026-06-10	2026-06-10	31.82
			KEYBOARD				
			01-2400-2401-90000 BUILDING COMPUTER KEYBOARD				31.82
002042	LENOVO (CANADA) INC	N100132684	BYLAW & BUILDING COMP	025226	2026-06-10	2026-06-10	733.24
			ACCES				
			01-2400-2401-90000 BUILDING CABLE & DOCK				251.20
			01-2400-2404-90000 BYLAW CABLE & DOCK				276.01
			01-2100-2101-50103 FIRE THINK PAD WITH DOCK				206.03
						Vendor Total	2,706.89
002041	LIGHTNING EQUIPMENT SALE 49640		F150 UPGRADES	025227	2026-06-10	2026-06-10	2,191.07
			01-2100-2101-90001 F150 UPGRADES				2,191.07
001201	LISTOWEL AUTO GLASS LTD 8713-13671471		GRADER GLASS DOOR	025228	2026-06-10	2026-06-10	638.45
			01-3800-3825-50553 GRADER GLASS DOOR				638.45
002040	LOUCKS & LOUCKS LLP IN TR 06 09 2026		LEGAL SETTLEMENT	025229	2026-06-10	2026-06-10	43,500.00
			WEIGEL/GIBSON				
			01-0000-0000-51010 LEGAL SETTLEMENT WEIGEL/GIBSON				43,500.00
001165	MAITLAND VALLEY CONSERV. 11471		SUGAR MAPLES X30	025230	2026-06-10	2026-06-10	900.61
			01-3100-3104-50555 SUGAR MAPLES X30				900.61
001391	MICROAGE BASICS	579187	PW LASER CARTRIDGE	025231	2026-06-10	2026-06-10	109.19
			01-3900-3901-50555 PW LASER CARTRIDGE				109.19
001391	MICROAGE BASICS	579431	PAPER	025231	2026-06-10	2026-06-10	235.04
			01-7100-7101-50555 PAPER				235.04
001391	MICROAGE BASICS	48894	FD COLOUR 478/ BLK 395	025231	2026-06-10	2026-06-10	66.17
			01-2100-2101-50200 FD COLOUR 478/ BLK 395				66.17
001391	MICROAGE BASICS	48818	COLOUR 2468/BLK 3153	025231	2026-06-10	2026-06-10	231.77
			01-1300-0000-50200 COLOUR 2468/BLK 3153				231.77
						Vendor Total	642.17
001185	MIDWESTERN EQUIPMENT (LI64610		BEARING/COUPLE/OIL	002020	2026-06-03	2026-06-03	479.19
			SEAL				
			01-3800-3835-50554 BEARING/COUPLE/OIL SEAL				479.19
001185	MIDWESTERN EQUIPMENT (LI64668		DIS COVER	002020	2026-06-03	2026-06-03	110.69

# Accounts Payable

Bills and Accounts May 13 - Jun 11 2026

Vendor 000000 Through 999999

Invoice Entry Date 2026-05-13 to 2026-06-11 Paid Invoices Cheque Date 2026-05-13 to 2026-06-11

Vendor Number	Vendor Name	Invoice Number	Invoice Desc	Chq Nbr	Invoice Date	Entry Date	Amount
			01-7100-0000-50556	DIS COVER			110.69
001185	MIDWESTERN EQUIPMENT (LI64727		BEARING/OIL SEAL/COUPLE	002020	2026-06-03	2026-06-03	662.65
		01-3800-3835-50554	BEARING/OIL SEAL/COUPLE				662.65
001185	MIDWESTERN EQUIPMENT (LI64746		BOLTS FOR MOWER	002020	2026-06-03	2026-06-03	577.45
		01-3800-3835-50553	BOLTS FOR MOWER				577.45
001185	MIDWESTERN EQUIPMENT (LI64524		OIL & CHARGE FILTER	002020	2026-06-03	2026-06-03	21.15
		01-9200-0000-50555	OIL & CHARGE FILTER				21.15
001307	MIDWESTERN NEWSPAPER G33161		NOTICE-WEED CONTROL	025174	2026-05-19	2026-05-19	423.18
		01-3100-3106-50556	NOTICE-WEED CONTROL				423.18
001307	MIDWESTERN NEWSPAPER G33290		HOWICK HOMECOMING ADVERTISE	025197	2026-05-28	2026-05-28	226.00
		01-2100-2101-50250	HOWICK HOMECOMING ADVERTISE				226.00
001307	MIDWESTERN NEWSPAPER G33560		NOTICE OF PESTICIDE USE	025232	2026-06-10	2026-06-10	423.19
		01-3100-3106-50556	NOTICE OF PESTICIDE USE				423.19
						Vendor Total	1,072.37
002002	MIKE'S CUSTOM WELDING & FMCW2460		VEHICLE SHELF UPGRADES	025198	2026-05-28	2026-05-28	5,294.05
		01-2100-2101-90001	VEHICLE SHELF UPGRADES				5,294.05
001038	MINISTER OF FINANCE-DRAIN 1440934264-6		TILE DRAIN DEB #2020-01	025199	2026-05-28	2026-05-28	5,475.48
		01-8500-0000-53100	TILE DRAIN DEB #2020-01				4,091.60
		01-8500-0000-53200	TILE DRAIN DEB #2020-01				1,383.88
001038	MINISTER OF FINANCE-DRAIN 1442664362-6		TILE DRAIN DEB #2020-02	025233	2026-06-10	2026-06-10	6,793.39
		01-8500-0000-53100	TILE DRAIN DEB #2020-02				5,076.41
		01-8500-0000-53200	TILE DRAIN DEB #2020-02				1,716.98
						Vendor Total	12,268.87
001142	MINISTER OF FINANCE-EHT MAY 2026 EHT		MAY 2026 EHT	002021	2026-06-03	2026-06-03	2,615.54
		01-0000-0000-25110	MAY 2026 EHT				2,615.54
001888	MINISTER OF FINANCE-FIRE 102505261241034		OFC REG FEES OCT-DEC 2025	025200	2026-05-28	2026-05-28	65.00
		01-2100-2101-50103	OFC REG FEES OCT-DEC 2025				65.00
001889	MINISTER OF FINANCE-MISC 2026 CAO FORUM		2026 CAO FORUM - JUNE	025175	2026-05-19	2026-05-19	90.00
		01-1300-0000-50103	2026 CAO FORUM - JUNE				90.00
001063	MINISTER OF FINANCE-OPP 392905261008077		JAN-MAR LSR REIMB	025234	2026-06-10	2026-06-10	-369.00
		01-2200-0000-50556	JAN-MAR LSR REIMB				-369.00
001063	MINISTER OF FINANCE-OPP 392805260947078		APRIL POLICING	025234	2026-06-10	2026-06-10	50,777.00
		01-2200-0000-50556	APRIL POLICING				50,777.00
						Vendor Total	50,408.00

# Accounts Payable

Bills and Accounts May 13 - Jun 11 2026

Vendor 000000 Through 999999

Invoice Entry Date 2026-05-13 to 2026-06-11 Paid Invoices Cheque Date 2026-05-13 to 2026-06-11

Vendor Number	Vendor Name	Invoice Number	Invoice Desc	Chq Nbr	Invoice Date	Entry Date	Amount
001894	MITCH ROWLEY PLUMBING	2680	FH PLUMBING UPGRADE	025201	2026-05-28	2026-05-28	3,718.10
			01-2100-2101-50554 FH PLUMBING UPGRADE				3,718.10
001174	MUNICIPALITY OF MORRIS-TL20426		HYSLOP DRAIN MAINT	025235	2026-06-10	2026-06-10	174.81
			01-8400-8433-12810 HYSLOP DRAIN MAINT				174.81
001676	ONTARIO ASSOCIATION OF FI2026-05-19		2026 O AFC MEMBERSHIP-J KESNTER	025176	2026-05-19	2026-05-19	316.40
			01-2100-2101-50104 2026 O AFC MEMBERSHIP-J KESNTER				316.40
001081	ONTARIO MUNICIPAL EMPLOYMAY 2026		MAY 2026	025236	2026-06-10	2026-06-10	23,575.74
			01-0000-0000-25110 MAY 2026				23,575.74
001203	ONTARIO ONE CALL	2026050167	NOTIFICATION SERVICE	025237	2026-06-10	2026-06-10	156.03
			01-3900-3901-50556 NOTIFICATION SERVICE				156.03
001091	P. E. INGLIS HOLDINGS INC.	54642	PORTABLE UNIT	025238	2026-06-10	2026-06-10	180.80
			01-4300-0000-50556 PORTABLE UNIT				180.80
001674	PBJ CLEANING DEPOT	54176-02	TUB METAL WALL RACK/HOLDER	025202	2026-05-28	2026-05-28	212.39
			01-2100-2101-50205 TUB METAL WALL RACK/HOLDER				212.39
001196	PETER KING	MAY 28/26	GAS FOR MOWER-FORDWICH	025203	2026-05-28	2026-05-28	40.00
			01-9400-0000-50555 GAS REG 21.63L @ 1.849				40.00
001020	PUROLATOR COURIER LTD.	595302264	SGS CANADA INC SHIPPING	025204	2026-05-28	2026-05-28	6.28
			01-4200-0000-50556 SGS CANADA INC SHIPPING				6.28
001020	PUROLATOR COURIER LTD.	595307150	SGS CAN/OMERS/ MOF	025204	2026-05-28	2026-05-28	25.39
			01-4200-0000-50556 SGS CANADA				13.27
			01-1300-0000-50210 OMERS/ MOF				12.12
001020	PUROLATOR COURIER LTD.	520278965	CAN DIRECT/BEREAV AUTHOR	025204	2026-05-28	2026-05-28	15.23
			01-1300-0000-50210 CAN DIRECT/BEREAV AUTHOR				15.23
001020	PUROLATOR COURIER LTD.	595312141	MOF/ BM ROSS POSTAGE	025239	2026-06-10	2026-06-10	12.56
			01-1300-0000-50210 MOF/ BM ROSS POSTAGE				12.56
Vendor Total							59.46
001594	RADAR AUTO PARTS - BRUSS5341-507072		VALVE STEM	025240	2026-06-10	2026-06-10	2.94
			01-3900-3901-50555 VALVE STEM				2.94
001064	RECEIVER GENERAL FOR CAIMAY 1-15 2026		PP#9 MAY 1-15 2026	002015	2026-05-22	2026-05-22	20,187.39
			01-0000-0000-25100 PP#9 MAY 1-15 2026				20,187.39
001064	RECEIVER GENERAL FOR CAIMAY 16-31 2026		PP#10 MAY 16-31 2026	002022	2026-06-03	2026-06-03	19,307.43
			01-0000-0000-25100 PP#10 MAY 16-31 2026				19,307.43
001732	SANI GEAR INC	22572	SUIT CLEANING & REPAIRS	025177	2026-05-19	2026-05-19	1,088.15

# Accounts Payable

Bills and Accounts May 13 - Jun 11 2026

Vendor 000000 Through 999999

Invoice Entry Date 2026-05-13 to 2026-06-11 Paid Invoices Cheque Date 2026-05-13 to 2026-06-11

Vendor Number	Vendor Name	Invoice Number	Invoice Desc	Chq Nbr	Invoice Date	Entry Date	Amount
001732	SANI GEAR INC	22491	01-2100-2101-50554 SUIT CLEANING & REPAIRS				1,088.15
			SUIT CLEANING & REPAIRS	025177	2026-05-19	2026-05-19	1,126.89
			01-2100-2101-50554 SUIT CLEANING & REPAIRS				1,126.89
						Vendor Total	2,215.04
001303	SENTINEL PEST CONTROL	68698	HCC-MONTHLY PEST CONTROL	025178	2026-05-19	2026-05-19	81.10
001303	SENTINEL PEST CONTROL	68336	01-7100-7101-50556 HCC-MONTHLY PEST CONTROL				81.10
			FIREHALL -MONTHLY PEST CONTROL	025178	2026-05-19	2026-05-19	180.44
001303	SENTINEL PEST CONTROL	69339	01-2100-2101-50554 FIREHALL -MONTHLY PEST CONTROL				180.44
			FIREHALL - MONTHLY PEST CONTRO	025241	2026-06-10	2026-06-10	103.28
001303	SENTINEL PEST CONTROL	69666	01-2100-2101-50554 FIREHALL - MONTHLY PEST CONTRO				103.28
			HCC-MONTHLY PEST CONTROL	025241	2026-06-10	2026-06-10	81.10
			01-7100-7101-50556 HCC-MONTHLY PEST CONTROL				81.10
						Vendor Total	445.92
001918	SPRIET ASSOCIATES	26-0199	MERKLEY MD SURVEY	025205	2026-05-28	2026-05-28	45,505.10
			01-8400-8448-12810 MERKLEY MD SURVEY				45,505.10
001305	STILLWATER CONSULTING LII5919		FIRE LEARNING MGMT SYSTEM	025179	2026-05-19	2026-05-19	246.91
			01-2100-2101-50103 FIRE LEARNING MGMT SYSTEM				246.91
001210	SUNBELT RENTALS OF CANAI79603173-0003		BY-LAW FENCE PANEL & LIGHT	025242	2026-06-10	2026-06-10	94.92
			01-2400-2404-12810 BY-LAW FENCE PANEL & LIGHT				94.92
001425	T&T POWER GROUP	114702	GENERATOR SERVICE	025243	2026-06-10	2026-06-10	506.42
			01-3900-3901-50556 GENERATOR SERVICE				506.42
002039	TACOMA ENGINEERS	102596	WROX COLLAPSE ASSESSMENT	025180	2026-05-19	2026-05-19	7,345.00
			01-2400-2404-12810 WROX COLLAPSE ASSESSMENT				7,345.00
001359	TIM & BRENDA BUNKER	MAY 28/26	ENTRANCE PERMIT REFUND	025206	2026-05-28	2026-05-28	100.00
			01-3900-3970-43300 ENTRANCE PERMIT REFUND				100.00
001681	TOROMONT CAT	PS601196654	BELT 6 RIBS	025244	2026-06-10	2026-06-10	130.54
			01-3800-3831-50554 BELT 6 RIBS				130.54
001681	TOROMONT CAT	WO600866840	BACKHOE REPAIR AND INSPECTION	025244	2026-06-10	2026-06-10	29,682.67
			01-3800-3831-50554 BACKHOE REPAIR AND INSPECTION				29,682.67
						Vendor Total	29,813.21
001812	TREVOR TOUT CUSTOM DOZI4489		LANDFILL SKIDSTEER	025245	2026-06-10	2026-06-10	8,333.75
			01-4300-0000-50656 LANDFILL SKIDSTEER				8,333.75
001812	TREVOR TOUT CUSTOM DOZI4467		PLOW CUTS	025245	2026-06-10	2026-06-10	339.00
			01-3100-3107-50555 PLOW CUTS				339.00

# Accounts Payable

Bills and Accounts May 13 - Jun 11 2026

Vendor 000000 Through 999999

Invoice Entry Date 2026-05-13 to 2026-06-11 Paid Invoices Cheque Date 2026-05-13 to 2026-06-11

Vendor Number	Vendor Name	Invoice Number	Invoice Desc	Chq Nbr	Invoice Date	Entry Date	Amount
001812	TREVOR TOUT CUSTOM DOZI	4490	STONE FOR GROUND REPAIR	025245	2026-06-10	2026-06-10	368.66
			01-3100-3107-50555				368.66
						Vendor Total	9,041.41
001112	ULTIMATE PROPERTY MAINT	7503	SNOW DUMP CLEAN UP	025246	2026-06-10	2026-06-10	2,828.79
			01-3600-3601-50555				2,828.79
001420	WASTE MANAGEMENT	735336-0256-8	CURBSIDE COLLECTION	002023	2026-06-03	2026-06-03	12,409.35
			01-7100-7101-50556				198.81
			01-4400-0000-50656				1,057.68
			01-4300-0000-50656				8,565.00
			01-4300-0000-50656				2,587.86
001420	WASTE MANAGEMENT	6391-0677-2	SINGLE STREAM	002023	2026-06-03	2026-06-03	321.47
			01-4300-0000-50656				321.47
						Vendor Total	12,730.82
001072	WORKPLACE SAFETY & INSURANCE	2025 WSIB RECONCILIATION	2025 WSIB RECONCILIATION	002024	2026-06-03	2026-06-03	-236.48
			01-0000-0000-43110				-236.48
001072	WORKPLACE SAFETY & INSURANCE	APRIL 2026 INTEREST	APRIL 2026 INTEREST	002024	2026-06-03	2026-06-03	-19.75
			01-0000-0000-43110				-19.75
001072	WORKPLACE SAFETY & INSURANCE	MAY 2026 INTEREST	MAY 2026 INTEREST	002024	2026-06-03	2026-06-03	-4.31
			01-0000-0000-43110				-4.31
001072	WORKPLACE SAFETY & INSURANCE	MAY 2026	MAY 2026	002024	2026-06-03	2026-06-03	4,654.81
			01-0000-0000-25110				4,654.81
001072	WORKPLACE SAFETY & INSURANCE	MAY 2026 VFF	MAY 2026 VFF	002024	2026-06-03	2026-06-03	814.07
			01-2100-2101-50102				814.07
001261	WURTH CANADA LIMITED	26945458	MASS AIRFLOW SENSOR	025247	2026-06-10	2026-06-10	100.97
			01-3900-3901-50555				100.97
						Unpaid Invoices	0.00
						Paid Invoices	1,534,771.79
						Invoices Total	1,534,771.79
						Selected G/L Account Total	1,534,771.79
						Payroll PP#10	42,303.91
						Payroll PP#10 Council	5,868.98
						Payroll PP#11	42,821.11
						<b>Payroll Expenditures</b>	<b>90,994.00</b>
						<b>Grand Total Expenditures</b>	<b>1,625,765.79</b>



# Staff Report to Council

**Report From:** Scott Price, Manager of Public Works

**Meeting Date:** June 16, 2026

**Report:** PW-2026-15  
2026 Hot Mix Paving Tender Results

## Recommendation:

That Howick Council receives report PW-2026-15, Hot Mix Paving Tender Results for information;

And That Council authorize Howick Township to enter into an agreement with the Municipality of South Bruce for 50% of the cost of Hot Mix Paving Huron-Bruce Road (\$89,142.50) and 100% of the cost of Hot Mix Paving George Street, Gorrie (\$45,420.00), for the total tendered amount of \$134,562.50 plus unrecoverable HST, as outlined in South Bruce Tender No. PW-2026-03,

And That Council give first, second, and third and final reading to By-law No. 44-2026, being a By-law to Authorize the Entering into and Execution of an Agreement between the Municipality of South Bruce and the Corporation of the Township of Howick;

And That Council authorize the Manager of Public Works to execute the agreement and all associated documents for the above-mentioned projects.

## Report Overview

<b>Purpose of Report</b>	For Approval
<b>Council Priority Alignment</b>	Safe & Reliable Infrastructure
<b>Consultations</b>	<b>Stu Moffat, Manager of Operations - Municipality of South Bruce</b> <b>Caitlin Gillis, CAO/Clerk</b>
<b>Attachment(s) to Report</b>	Draft By-law 44-2026 – Agreement between the Corporation of the Township of Howick and the Municipality of South Bruce for Hot Mix Paving

## **Report Highlights**

- Tender documents were prepared and jointly issued by Township of Howick and Municipality of South Bruce staff.
- Following the Township's Procurement Policy, tender documents were posted on Bids and Tenders and sent directly to four local contractors.
- Two contractors viewed site locations in person.
- One tender was received before the closing deadline.

## **Context and Background**

Huron Bruce Road and George Street were both identified in Howick's 2025 Roads Needs Study as in need of resurfacing to extend their lifespan.

\$247,000 was included in the Public Works Department's 2026 Capital Budget for Asphalt Replacement.

Tender documents were prepared to resurface one block of Huron Bruce Road. This road is shared with the Municipality of South Bruce. Staff included all other Hot Mix Paving projects in the same tender to attract competitive pricing. Two contractors viewed locations of work requested. Staff met with contractors to answer any concerns.

Shoulder material was not included in this tender. Both Municipalities will work together to complete this work. This will be an extra cost to come out of

## **Discussion and Staff Recommendation(s)**

Staff are recommending that Council authorize the agreement with the Township of South Bruce, who has awarded the joint project to Lavis Contracting Co. Ltd.

Joint tendering has reduced the asphalt cost significantly compared to last year's tender price for asphalt per sq meter. Staff have received positive reviews from the chosen contractor's list of references.

## Impact Analysis

**Table 1: Municipality of South Bruce Tender Results PW-2026-03**

<b>Project Location</b>	<b>Total Project Cost</b>	<b>Howick's Portion of Project</b>
<b>Huron Bruce Road</b> After Bridge @ 911# 1568 to B-Line	<b>\$178,285.00</b>	<b>\$89,142.50</b> (shared with South Bruce)
<b>George Street (Gorrie)</b> Victoria St. to dead-end	<b>\$45,420.00</b>	<b>\$45,420.00</b>
	<b>Subtotal</b>	<b>\$134,562.50</b>
	<b>Un-Recoverable HST</b>	<b>\$2,368.30</b>
	<b>Total Project</b>	<b>\$136,930.80</b>

**Table 2: Variance**

**2026 Capital Budget for this project was \$247,000.00**

<b>2026 Capital Budget</b>	<b>\$247,000.00</b>
<b>Project Total</b> (including un-recoverable HST)	<b>\$136,930.80</b>
<b>Variance</b>	<b>\$110,069.20</b>

## Linkages

[Draft By-law 44-2026, Agreement with Municipality of South Bruce](#)

---

Respectfully submitted,

Scott Price, Manager of Public Works

**Corporation of the Township of Howick**

**By-law No. 44-2026**

---

**Being A By-Law To Authorize the Entering into and Execution of an Agreement between the Corporation of the Township of Howick and the Corporation of the Municipality of South Bruce for Hot Mix Paving as outlined in South Bruce Tender Documents PW-2026-03**

---

**WHEREAS** Subsection 5(1) of the *Municipal Act, S.O. 2001, c. 25* as amended, provides that the powers of a municipality shall be exercised by Council;

**AND WHEREAS** Subsection 5(3) of the *Municipal Act, 2001, S.O. 2001, c. 25*, as amended, provides that municipal power shall be exercised by By-law;

**AND WHEREAS** both parties have agreed to the Terms in the Contract attached as Schedule 'A' to this By-law;

**NOW THEREFORE IT BE ENACTED** by the Council of the Corporation of the Township Of Howick as follows:

1. That the Corporation of the Township of Howick enter into the Agreement (Schedule 'A') with The Corporation of the Municipality of South Bruce for Hot Mix Paving of Huron-Bruce Road and George Street, Gorrie, as outlined in South Bruce Tender PW-2026-03 (Schedule 'B').
2. That the Manager of Public Works is hereby authorized to execute and affix the Corporate Seal to an Agreement between the Corporation of the Township of Howick and the Corporation of the Municipality of South Bruce and any other relevant documents necessary for the execution of said Agreement.
3. That Schedules 'A' and 'B' form part of this by-law.
4. That this By-law shall come into force and take effect upon its final passage.
5. That this By-law may be cited as the "2026 Hot Mix Asphalt Paving" By-law.

**Read a first and second time this 16<sup>th</sup> day of June, 2026.**

**Read a third time and finally passed this 16<sup>th</sup> day of June, 2026.**

---

**Reeve Doug Harding**

---

**CAO/Clerk Caitlin Gillis**



**Agreement for Hot Mix Paving – Contract PW2026-3**

THIS AGREEMENT made in duplicate this 28 day of May, 2026

**BETWEEN: THE CORPORATION OF THE MUNICIPALITY OF SOUTH BRUCE**  
(hereinafter called the "Municipality")

AND

**TOWNSHIP OF HOWICK**  
(hereinafter called the "Township")

WITNESSETH:

In accordance with By-Law #2002-43 being a by-law to establish a Boundary Agreement between the neighbouring municipalities, being the Municipality of South Bruce and the Township of Howick, for the maintenance and repair of the shared boundary road (Huron-Bruce Road).

That any construction or capital work such as paving is agreed upon, and the costs for the work be shared equally between the two municipalities.

That the Municipality and the Township, in consideration of the fulfillment of their respective promises and obligations set forth in the tender PW2026-3, covenant and agree with each other as follows:

1. The Municipality of South Bruce shall act as an agent on behalf of the Township of Howick and to call for Tenders and to prepare and distribute the contract documents.
2. The Municipality of South Bruce and the Township of Howick are each Parties to this contract and shall individually have all the rights and privileges of the "Owner" as stipulated in the contract documents.
3. Enforcement of the Contract may be carried out collectively, or individually between any Parties, namely The Municipality of South Bruce, the Township of Howick and Lavis Contracting Co. Limited. (herein called the "Contractor").
4. Each of the Parties shall be severally liable for all provisions of the contract, including amounts owed to the Contractor. The Contractor shall not take action against any of the other Parties, for a breach of the Agreement committed by one Party.

5. The Contractor shall invoice the Municipality of South Bruce and the Township of Howick individually for the actual quantities used following the completion of their work. The Contractor is to submit an invoice indicating the amount and contract number to each individual Municipality for the work performed at each respective work location.
6. The Municipality of South Bruce shall be responsible for payment of the work on the boundary road, being the Huron-Bruce Road (Carrick/Howick) after the bridge at 911# 1568 to B-Line (Item A1 in the tender). The Municipality shall invoice the Township for 50% of this item, including shoulder gravel work.

**THE TOWNSHIP OF HOWICK**

I have the authority to bind the Corporation

  
\_\_\_\_\_  
SCOTT PRICE, MANAGER OF PUBLIC WORKS

**THE MUNICIPALITY OF SOUTH BRUCE**

I have the authority to bind the Corporation

  
\_\_\_\_\_  
STU MOFFAT, MANAGER OF OPERATIONS



A COLAS COMPANY

Cold In-Place Recycling – Asphalt Paving – Ready Mix Concrete Supply  
Excavating, Grading - Sand, Gravel - Sewer & Watermain

37462A Huron Rd., RR#2 Clinton, Ontario, N0M 1L0 – Phone: (519) 482-3694 – Fax: (519) 482-7886 – www.lavis.ca

Date: May 29, 2026  
To: Township of Howick

Attention: Scott Price  
Telephone:  
E-Mail: sprice@howick.ca  
Project: PW2026-3 - Hot Mix Paving

**Includes Addendums, #.**

We are pleased to submit a proposal to you as Contractor or Owner for furnishing the labour, materials and equipment required for the performance of the following described work (the "said work") at the above location and for the above owner.

Item	Description	Estimated Quantity	Unit	Unit Price	Amount
	<b>The Scope of Work is as follows:</b>				
	The following work was bid as a joint tender with the Municipality of South Bruce closing on Friday May 15, 2025. The work to be completed for the Township of Howick is as follows:				
<b>B1</b>	<b>George Street (Gorrie) - Victoria to Dead End</b> Cold Plane Existing Asphalt at Various Laneway Entrances 20-40mm Supply & Place 40mm HLL3 Surface Asphalt (7m Width)	80.00 320.00	m2 t	\$73.75 \$123.50	\$5,900.00 \$39,520.00 <b>\$45,420.00</b>
	<b>Notes:</b> - All work will be completed as per Contract No. PW2026-3 Specifications				

plus HST

It is understood that the foregoing is an estimate of the work and the materials and equipment required, and that payment shall be based on the stated unit prices for the actual work performed, and materials supplied and equipment used by the Company as determined upon completion of the work.

If the foregoing meets with your acceptance, kindly sign and return this proposal, which, upon receipt by us, becomes a binding contract. It is understood that the foregoing and the terms and conditions set forth on the accompanying page, will constitute the full and complete agreement between us.

**Accepted:**

By: Scott Price

Date: June 3 2026  
Contractor or Owner

Yours truly,

Jeff Morley, C.E.T.  
Lavis Contracting Co. Limited

Schedule 'B' to By-law 44-2026

**Agreement for Hot Mix Paving – Contract PW2026-3**

THIS AGREEMENT made in duplicate this \_\_\_\_\_ day of \_\_\_\_\_, 2026

BETWEEN: **THE CORPORATION OF THE MUNICIPALITY OF SOUTH BRUCE**  
(hereinafter called the "Municipality")

AND

**LAVIS CONTRACTING CO. LIMITED**  
(hereinafter called the "Contractor")

WITNESSETH:

That the Municipality and the Contractor, in consideration of the fulfillment of their respective promises and obligations set forth in the tender, covenant and agree with each other as follows:

The Contractor has carefully examined the provisions, plan, specifications and conditions, as noted in the Tender Document Contract PW2026-3 (hereinafter called the "Tender"), and has carefully examined the site and location of the work to be done under this contract, and the Contractor understands and accepts the said provisions, plans, specifications and conditions, and, for the prices set forth in the Tender, hereby offers to furnish all machinery, tools, apparatus and other means of construction, furnish all materials, except as otherwise specified in the Tender, and to complete the work in strict accordance with the provisions, plans, specifications, and conditions stipulated in the Tender.

Included with Tender is a Bid Bond in the amount specified in the Tender Requirements. The proceeds of this Bid Bond shall, upon acceptance of the Tender, constitute a deposit which shall be forfeited to the Municipality if the Contractor fails to file with the Municipality a Performance Bond, as required in the Tender, within fifteen (15) days from the date of Acceptance of the Tender.

The Contractor will file with each Municipality a completed performance bond, signed and sealed with a recognized bonding company, in the amount of 50% of the Total Tender Price. Upon receipt of such a bond, the tender deposit will be returned to the Contractor. The Performance Security shall remain in force and effect through the duration of the Contract and Warranty period. Through the whole warranty period (one year from the completion of the Project) the Municipality will maintain the securities in the amount equal to 50% of the total Contract value.

It is agreed that the Tender quantities are estimated only and may be increased or decreased by the Municipality without alteration of the contract price, however, such increase or decrease shall not exceed 20 percent.

I / WE (the Contractor) promise to commence work on \_\_\_\_\_ (to be completed by Contractor) and to diligently perform the work continuously without undue delay and further promise to complete the work by **September 1, 2026.**

The Municipality covenants with the Contractor that the Contractor having in all respects complied with the provisions of the Tender, will be paid for the work the sum specified on the Form of Tender and Agreement subject to such additions and deductions as may properly be made under the terms hereof and subject to the provision that the Municipality may make payments on account monthly or otherwise.

BY \_\_\_\_\_  
Name of Firm or Individual (Hereafter referred to as "The Contractor")

ADDRESS \_\_\_\_\_

\_\_\_\_\_  
Name of Authorized Person Signing for Firm

\_\_\_\_\_  
Signature

\_\_\_\_\_  
Office/Position of Person Signing for Firm

Contractor  
Affix  
Corporate Seal

**THE MUNICIPALITY OF SOUTH BRUCE**

\_\_\_\_\_  
STU MOFFAT, MANAGER OF OPERATIONS

I have the authority to bind the Corporation

# Hot Mix Paving - PW2026 – 3

**Friday, May 15, 2026 @ 1:30 p.m.**

COMPANY	BID BOND/ CHEQUE	SUBTOTAL	HST	TOTAL (incl HST)
Duncor				
Lavis	✓	1,105,315.00 45,420.00	143,690.95 <del>5,904.60</del>	1,249,005.95 51,324.60
Miller Group				
Walker				
MEI				
Drock Paving				
Capital Paving				
Armstrong Paving				
Lavis				

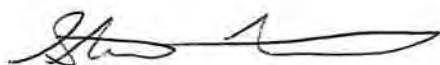
Stu Moffat  

Debbie Kennedy  

Scott Price  

# CCDC 220 – 2024 BID BOND



Bond No.: 7091146-26-0338

Bond Amount: \$-10%-

**Lavis Contracting Co. Limited** as principal, hereinafter called the Principal, and **INTACT INSURANCE COMPANY** a corporation duly authorized to transact the business of Suretyship in all Provinces and all Territories in Canada as surety, hereinafter called the Surety, are held and firmly bound unto **Municipality of South Bruce** as obligee, hereinafter called the Obligee, in the amount of **TEN PERCENT OF THE TENDER PRICE Dollars (\$ -10%- )** lawful money of Canada, for the payment of which sum the Principal and the Surety bind themselves, their heirs, executors, administrators, successors and assigns, jointly and severally.

WHEREAS, the Principal has submitted a written bid to the Obligee, for (Name, Location or Address, and Project Number, if any):  
**PW 2026-3 - Hot Mix Paving**

The condition of this obligation is such that if the Principal shall have the bid accepted within the Validity Period and:

- a) Enters into a formal contract; and,
- b) Gives such bond or bonds as may be specified in the Obligee's bid documents from a Surety duly authorized to transact the business of Suretyship in the jurisdiction of the project,

then this obligation shall be void. Otherwise, provided the Obligee takes all reasonable steps to mitigate the amount of such excess costs, the Principal and the Surety will pay to the Obligee the difference in money between the amount of the bid of the Principal and the amount for which the Obligee legally contracts with another party for the work, supplies and services which were specified in the said bid, if the latter amount be in excess of the former.

The "Validity Period" as used herein shall mean the time period prescribed in the Obligee's bid documents for acceptance of the bid, or, if no time period is specified in the Obligee's bid documents, sixty (60) calendar days from the closing date of the bid.

By agreement between the Principal and the Obligee, the Validity Period may be extended by up to sixty (60) calendar days without notice to the Surety. Further or longer extensions of the Validity Period require prior consent of the Surety.

The Principal and Surety shall not be liable for a greater sum than the Bond Amount.

It is a condition of this bond that any suit or action must be commenced within seven (7) months of the date of this Bond. In the province of Quebec, the coverage period of this bond expires seven (7) months after the date of this Bond.

No right of action shall accrue hereunder to or for the use of any person or corporation other than the Obligee named herein, or the heirs, executors, administrators or successors of the Obligee.

**The Surety:**

**INTACT INSURANCE COMPANY**

(corporate name)

**1100 - 999 W. Hastings St., Vancouver, BC V6C 2W2**

(address)

**N/A**

(fax)

**west.surety@intact.net**

(email)

**The Obligee:**

**Municipality of South Bruce**

(proper name)

**21 Gordon St. East Teeswater, ON N0G 2S0**

(address)

**N/A**

(fax)

**N/A**

(email)

**The Principal:**

**Lavis Contracting Co. Limited**

(corporate name)

**37462A Huron Road, RR #2 Clinton, ON N0M 1L0**

(address)

(fax)

(email)

**IN WITNESS WHEREOF**, the Principal and the Surety have Signed and Sealed this Bond dated **8th** day of **May**, in the year **2026**

SIGNED and SEALED

in the presence of

ATTORNEY IN FACT

Principal



(sign)

Signature

**JEFF MORLEY, OPERATIONS MANAGER**

(name of person signing)

Surety



(sign)

Signature

**SHANNON GASS, Attorney-In-Fact**



## Agreement to Bond

(Surety's Consent)

Consent of Surety No. 7091146-26-0338

To: Municipality of South Bruce

Should the tender of: LAVIS CONTRACTING CO. LIMITED

For: PW 2026-3 - Hot Mix Paving

be accepted within the time period prescribed in the tender, or if no time period is specified, within sixty (60) days from the closing date of tender, and a written contract entered into, we the undersigned do hereby agree to become bound as Surety and will issue

**A Performance Bond equal to 50%**  
**A Labour and Material Payment Bond equal to 50%**

of the tender price guaranteeing faithful performance of said contract.

This Consent of Surety shall cease and be null and void after **thirty (30)** days from the award of contract.

Any suit filed against the Surety with respect to this Surety's Consent must be initiated and duly served on the Surety within seven (7) months of the date hereof.

Tender Date: 15<sup>TH</sup> day of MAY, 2026

Dated: **May 8, 2026**

INTACT INSURANCE COMPANY

  
\_\_\_\_\_(Seal)  
Shannon Gass, Attorney-in-Fact

**FORM OF TENDER – Bid Form**

LOCATION		WORK REQUIREMENTS	ESTIMATED QUANTITY	UNIT PRICE	TOTAL PRICE
<b>Municipality of South Bruce (Items A1 to A3)</b>					
#A1	Huron-Bruce Rd (Carrick/ Howick) After bridge @ 911# 1568 to B-Line	Cold Plane existing asphalt 40 mm	50 m2	\$ 43.70	\$ 2,185.00
		Supply and Place HMA padding 15 mm	600 Tonne	\$ 85.50	\$ 51,300.00
		Supply and Place 40 mm surface lift HL3, including Shuttle Buggy (7 m width)	1,300 Tonne	\$ 96.00	\$ 124,800.00
<b>TOTAL - Location #A1</b>					<b>\$ 178,285.00</b>
#A2	Conc. 12E (Carrick) SR 20N to 50 m east of 911# 6 @ bridge	Cold Plane existing asphalt 40 mm	120 m2	\$ 22.00	\$ 2,640.00
		Supply and Place HMA padding 15 mm	1,600 Tonne	\$ 85.50	\$ 136,800.00
		Supply and Place 40 mm surface lift HL3, including Shuttle Buggy (7 m width)	4,400 Tonne	\$ 96.00	\$ 422,400.00
<b>TOTAL - Location #A2</b>					<b>\$ 561,840.00</b>
#A3	Conc. 2 (Culross) West of SR 25S to 200 m west of 911# 2517	Cold Plane existing asphalt 40 mm	120 m2	\$ 19.50	\$ 2,340.00
		Supply and Place HMA padding 15 mm	1,100 Tonne	\$ 85.50	\$ 94,050.00
		Supply and Place 40 mm surface lift HL3, including Shuttle Buggy (7 m width)	2,800 Tonne	\$ 96.00	\$ 268,800.00
<b>TOTAL - Location #A3</b>					<b>\$ 365,190.00</b>

<b>Municipality of South Bruce – Bid Summary</b>		
Item #	Location	Total
#A1	Huron-Bruce Rd (Carrick/Howick)	\$ 178,285.00
#A2	Concession 12E (Carrick)	\$ 561,840.00
#A3	Concession 2 (Culross)	\$ 365,190.00
<b>Subtotal</b>		<b>\$ 1,105,315.00</b>
<b>HST</b>		<b>\$ 143,690.95</b>
<b>Total</b>		<b>\$ 1,249,005.95</b>

LOCATION		WORK REQUIREMENTS	ESTIMATED QUANTITY	UNIT PRICE	TOTAL PRICE
<b>Township of Howick (Item B1)</b>					
#B1	George Street (Gorrie) Victoria St. to Deadend	Cold Plane existing asphalt at various laneway entrances 20 to 40 mm	80 m2	\$ 73.75	\$ 5,900.00
		Supply and Place 40 mm surface lift HL3 (7 m width)	320 Tonne	\$ 123.50	\$ 39,520.00
<b>TOTAL - Location #B1</b>					<b>\$ 45,420.00</b>

<b>Township of Howick – Bid Summary</b>		
Item #	Location	Total
#B1	George Street (Gorrie)	\$45,420.00
	HST	\$ 5,904.60
	<b>Total</b>	<b>\$ 51,324.60</b>

### FORM OF TENDER

Bidders shall list 3 other companies or organizations for which they have completed similar work.

LIST OF REFERENCES			
NAME	ADDRESS	CONTACT	PHONE NO.
SEE ATTACHED PAGE			

Bidders shall list all sub-contractors who they propose to use in the completion of this project.

LIST OF SUB CONTRACTORS		
COMPANY NAME & ADDRESS	CONTACT PERSON	PHONE NO.
OWN FORCES		



A COLAS COMPANY

*Cold In-Place Recycling – Asphalt Paving – Ready Mix Concrete Supply  
Excavating, Grading – Sand, Gravel – Sewer & Watermain*

**37462A HURON RD., RR#2 CLINTON, ONTARIO, N0M 1L0 – PHONE: (519) 482-3694 – FAX: (519) 482-7886 – WWW.LAVIS.CA**

**PROOF OF ABILITY – ASPHALT PAVING**

Reference Organization Name:	Muni. Of Bluewater
Work Performed As:	BW-RDS-01-2025, General Contractor
Brief Project Description/Location:	Airport Line Hot Mix HL4 – 9,410.00t
Total Project Value:	\$1,021,355.00
Reference Contact/Position:	Dave Kester, Manager of Public Works
Reference Email:	publicworks@municipalityofbluewater.ca
Telephone Number:	(519) 236-4351 ext. 221
Project Completion Date:	June 2025

Reference Organization Name:	TWP of Huron-Kinloss
Work Performed As:	Huron Kinloss – 2025 Asphalt Paving, General Contractor
Brief Project Description/Location:	Various Urban Steets in Point Clark & Rual Road Hot Mix HL4 Kinloss Culross – 4,596t
Total Project Value:	\$679,432.85
Reference Contact/Position:	John Yungblut, Director of Public Works
Reference Email:	jyungblut@huronkinloss.com
Telephone Number:	(519) 395-3735 ext. 130
Project Completion Date:	October 2025

Reference Organization Name:	Muni. Of Central Huron
Work Performed As:	CH-2025-004, General Contractor
Brief Project Description/Location:	Milling & Hot Mix Paving Various Urban Streets in Clinton & Rual Roads Summerhill Road HL4 – 13,386.14t
Total Project Value:	\$1,298,970.86
Reference Contact:	Brady Nolan
Reference Email:	bnolan@centralhuron.com
Telephone Number:	(519) 482 -3997 ext.1235
Project Completion Date:	November 2025

Reference Organization Name:	Township of Ashfield-Colborne-Wawanosh
Work Performed As:	ACW – 2025 Asphalt
Brief Project Description/Location:	Various Roads: Supply & Place Hot Mix HL4 – 8,835.00t
Total Project Value:	\$1,032,866.75
Reference Contact:	Thomas McCarthy
Reference Email:	pws@acwtownship.ca
Telephone Number:	(519) 524-4669
Project Completion Date:	November 2025

### FORM OF TENDER - AGREEMENT

I, the undersigned, having carefully examined the Bid Documents, having received, carefully examined and incorporated

Addenda No. \_\_\_\_\_ to No. \_\_\_\_\_

No addenda received

inclusive, and having examined all conditions, circumstances and limitations affecting the work, offer to enter into a contract with the Municipality to perform the work required by the Tender Documents.

#### Declarations

I/We the undersigned, declare that:

1. I/We agree to undertake the work, in compliance with the tender document and specifications for the prices set out in the submitted Form of Tender – Bid Price.
2. No person, firm or corporation other than the undersigned has any personal interest in this bid or in the proposed contract for which this bid is made.
3. This bid is irrevocable and is open for acceptance by the Municipality for a period of **sixty (60) days** from the date of submission.

LAVIS CONTRACTING CO. LTD

Company Name

37462 A HURON RD

Address

CLINTON, ON N0M 1L0

City and Postal Code

(519) 482-3694

Telephone Number

lavis@lavis.ca

Email Address

  
Authorized Signature

JEFF MORLEY

Name (Print or Type)

OPERATIONS MANAGER

Title

(519) 482-7886

Fax Number

May 15, 2026

Date

I have the authority to bind the Corporation (if applicable).



## Your clearance(s) / Vos certificats de décharge

We confirm that the business(es) listed below are active and in good standing with us.  
Nous confirmons que la ou les entreprises énumérées ci-dessous sont actives et que leurs comptes sont en règle.

Contractor legal or trade name / Raison sociale ou appellation commerciale de l'entrepreneur	Contractor address / Adresse de l'entrepreneur	Contractor NAICS Code and Code Description / Code du SCIAN de l'entrepreneur et description	Clearance certificate number / Numéro du certificat de décharge	Validity period (dd-mmm-yyyy) / Période de validité (jj- mmm-aaaa)
LAVIS CONTRACTING CO. LIMITED / ...	101-281 HILLMOUNT RD, ATTN BILL SCOTT, MARKHAM, ON, L6C2S3, CA	212323: Sand and gravel mining and quarrying 237310: Highway, street and bridge construction 327320: Ready-mix concrete manufacturing 488490: Other support activities for road transportation	A0000JNL6H	20-Feb-2026 to 19-May-2026

Under Section 141 of the *Workplace Safety and Insurance Act*, the WSIB waives our right to hold the principal (the business that has entered into a contractual agreement with the contractor/subcontractor) liable for any unpaid premiums and other amounts the contractor may owe us for the validity period specified.  
Aux termes de l'article 141 de la *Loi sur la sécurité professionnelle et l'assurance contre les accidents du travail*, la WSIB renonce à son droit de tenir l'entrepreneur principal (l'entreprise qui a conclu une entente contractuelle avec l'entrepreneur ou le sous-traitant) responsable de toute prime impayée et autre montant que l'entrepreneur pourrait lui devoir pour la période de validité indiquée.

WSIB Head Office: 200 Front Street West  
Toronto, Ontario, Canada M5V 3J1

Siège social : 200, rue Front Ouest  
Toronto (Ontario) Canada M5V 3J1

1-800-387-0750 | TTY/ATS 1-800-387-0050  
employeraccounts@wsib.on.ca | wsib.ca

# Staff Report to Council

---

**Report From:** Scott Price

**Meeting Date:** June 16, 2026

**Report:** PW-2026-16  
Roadside Flail Mower Tender Results

---

**Recommendation:**

That Howick Council receives report PW-2026-16, Roadside Flail Mower Tender Results for information;

And that Council award Tender PW-2026-03 to Midwestern Equipment (Listowel) Ltd. In the amount of \$21,355.87 (plus unrecoverable HST) for the purchase of a Roadside Flail Mower.

And that the CAO/Clerk and/or the Manager of Public Works be authorized to sign and execute the agreement and all relevant documents.

## Report Overview

<b>Purpose of Report</b>	For Approval
<b>Council Priority Alignment</b>	Safe & Reliable Infrastructure
<b>Consultations</b>	<b>Caitlin Gillis, CAO/Clerk</b> <b>Shawn Nicholson, Public Works Lead Hand</b>
<b>Attachment(s) to Report</b>	Tender Results: RFT PW-2026-03 Roadside Flail Mower.  Draft By- law 45-2026

## Report Highlights

- The purchase of a new Roadside Flail Mower was included in the 2026 Capital Budget for the Public Works Department.
- Following the Township's Procurement Policy, tender documents were

posted on Bids and Tenders.

- Nine submissions were received. The lowest submissions from Equipements Track Inc. unfortunately did not meet all specifications outlined in the tender documents.

## **Context and Background**

The Public Works department cuts all Howick roadsides spring and fall to maintain all municipal rights-of-way.

The existing Rotary Disc Mower was purchased in 2023. During the 2025 season, it was damaged and a rental flail mower was leased to test. The construction of the leased flail mower was stronger than the existing disc mower and allowed ditch mowing to be completed to the property line in most locations. Mowing the whole ditch controls weeds and prevents tree and shrub overgrowth.

Based on staff experience with the previous disc mower, and the performance of the rental flail mower, staff were able to compile a list of specifications, design and features for the new roadside mower tender.

## **SPECIFICATIONS**

**Working Width:** 78.7" (2m)

**Horsepower Requirement:** 70.0 – 130HP

**PTO Speed:** 540RPM

**Rotor Diameter:** 450mm (approximately 17.7")

**Rotor Speed:** 1858RPM

**Weight:** Approximately 870kg (1918lbs)

**Offset Ability:** Hydraulic pivoting (multi-tilt) allows for a significant offset for ditch maintenance.

**Operating Angles:** Can operate from +90 degrees to -65 degrees, suitable for bank and ditch mowing.

## **DESIGN AND FEATURES**

**Hitch Type:** 3-point hitch

**Transmission:** Gearbox with integrated freewheel (rated up to 150HP) with 5-belt drive

**Rotor Technology:** High-speed rotary with heavy-duty hammers (13 per meter)

**Roller:** Standard 195mm (7.7") diameter rear roller with self-cleaning capabilities and bearing protection.

**Safety & Durability:** Features a double skin frame for increased life and hydraulic accumulators to prevent damage upon obstacle collision.

## **Discussion and Staff Recommendation(s)**

Staff recommend purchasing the Kubota Flail Mower from Midwestern Equipment Ltd as it meets all of our specifications, design and features.

**Table 1: Top 6 Bid Submissions** (full list in attachments)

<b>Company</b>	<b>Requirements Met</b>	<b>Unofficial Value</b>
Équipements Track Inc.	No	\$14,330.77
Équipements Track Inc.	No	\$21,568.20
Équipements Track Inc.	Yes	\$22,525.28
Midwestern Equipment (Listowel) Ltd.	Yes	\$21,355.87
PE Premier Equipment ULC	Yes	\$23,730.00
Partners Solutions	Yes	\$26,470.25

## Impact Analysis

In the 2026 Capital Budget staff budgeted \$24,000.00 for the purchase of a new flail mower.

**Table 2: Variance**

<b>Midwestern Equipment (Listowel) Ltd.</b>	\$21,355.87
Unrecoverable HST	\$375.86
<b>Total</b>	\$21,731.73
2026 Capital Budget	\$24,000.00
<b>Variance</b>	<b>\$2,268.27</b>

## Linkages

[Tender Results: RFT PW-2026-03 Roadside Flail Mower](#)

[Draft By- law 45-2026](#)

---

Respectfully submitted,

**Scott Price, Manager of Public Works**

# RFT PW-2026-03

## RFT PW-2026-03 Roadside Flail Mower

Closing Date: Thursday, June 4, 2026

### Submission Summary

Vendor	City/Province	Submission Name	Unofficial Value or Notes
Équipements Track Inc.	Richmond, Québec	Submission 1	\$14,330.77
Équipements Track Inc.	Richmond, Québec	Submission 1	\$21,568.20
Équipements Track Inc.	Richmond, Québec	Submission 1	\$22,525.28
Midwestern Equipment (Listowel) Ltd.	Listowel, ON	Submission 1	\$21,355.87
PE Premier Equipment ULC	Elmira, ON	Submission 1	\$23,730.00
Partners Solutions	Orillia, Ontario	Submission 1	\$26,470.25
COLVOY ENTERPRISES 2012 LTD	Tillsonburg, ON	Submission 1	\$37,416.92
AMACO EQUIPMENT	MISSISSAUGA, ON	Submission 1	\$38,985.00
Equipment Ontario Inc	Lindsay, ON	Submission 1	\$53,955.24

---

Witness (Print Name) Signature Date

---

Witness (Print Name) Signature Date

---

Witness (Print Name) Signature Date

**Corporation of the Township of Howick**

**By-law No. 45-2026**

---

**Being A By-Law To Authorize the Entering Into and Execution of an Agreement Between the Corporation of the Township of Howick and Midwestern Equipment (Listowel) Ltd. for the Supply and Delivery of one (1) Roadside Flail Mower**

---

**WHEREAS** Subsection 5(1) of the Municipal Act, S.O. 2001, c. 25 as amended, provides that the powers of a municipality shall be exercised by Council;

**AND WHEREAS** Subsection 5(3) of the Municipal Act, 2001, S.O. 2001, c. 25, as amended, provides that municipal power shall be exercised by By-law;

**NOW THEREFORE IT BE ENACTED** by the Council of the Corporation of the Township Of Howick as follows:

1. That the Corporation of the Township of Howick enter into an Agreement with Midwestern Equipment (Listowel) Ltd., attached hereto as Schedule "A", which forms part of this by-law.
2. That the Reeve and CAO/Clerk are hereby authorized to execute and affix the Corporate Seal to an Agreement between the Corporation of the Township of Howick and Midwestern Equipment (Listowel) Ltd. for the Supply and Delivery of One (1) Roadside Flail Mower.
3. That this By-law shall come into force and take effect upon its final passage.

**Read a first and second time this 16<sup>th</sup> day of June, 2026.**

**Read a third time and finally passed this 16<sup>th</sup> day of June, 2026.**

---

**Reeve Doug Harding**

---

**CAO/Clerk Caitlin Gillis**

Schedule 'A' to By-law 45-2026  
**FORM OF TENDER AND AGREEMENT**

The Contractor has carefully examined the provisions, plans, specifications and conditions attached to this tender package and has carefully examined the site and locations of the work to be done under this contract and the Contractor understands and accepts the said provisions, plans, specifications and conditions, and for the prices set forth in this tender, hereby offers to furnish all machinery, tools, apparatus and other means of construction, furnish all materials, except as otherwise specified in the contract, and to complete the work in strict adherence to the provisions, plans, specifications and conditions attached to this tender.

It is agreed that the tender quantities are estimated only and may be increased or decreased by the Township of Howick's Manager of Public Works or their designate, without alteration of the contract unit price.

I/We the Contractor hereby certify that we will commence work outlined in the Scope of Work no earlier than \_\_\_\_\_, 2026, and to diligently perform the work continuously without undue delay and further promise to substantially complete the work on or before \_\_\_\_\_, 2026.

This form of Tender and Agreement when signed by the Contractor shall constitute a formal and binding contract when accepted and signed on behalf of the Township of Howick.

Legal Business Name (Successful Bidder)	Address of Successful Bidder
-----------------------------------------	------------------------------

Signature of Authorized Signing Officer (I have the authority to bind the company)	Email
---------------------------------------------------------------------------------------	-------

Name and Title of Signing Officer	Registered Business Number
-----------------------------------	----------------------------

\*\*\*\*\*  
This section for completion on acceptance by the Township of Howick

Signature of Township Officer Affix Corporate Seal	Township Officer Name and Title
-------------------------------------------------------	---------------------------------

Signature of Township Officer	Township Officer Name and Title
-------------------------------	---------------------------------

Acceptance date \_\_\_\_\_, 2026

# RFT PW-2026-03 - RFT PW-2026-03 Roadside Flail Mower

## Vendor Details

Company Name: Midwestern Equipment (Listowel) Ltd.  
Address: 8592 Hwy 23 North  
P.O. Box 93  
Listowel, ON N4W 3H2  
Contact: David Diehl  
Email: dave@midwesternequipment.ca  
Phone: 519-291-2697  
Fax: 519-291-5132  
HST#: R876562745

## Submission Details

Created On: Wednesday May 27, 2026 08:10:46  
Submitted On: Friday May 29, 2026 13:55:10  
Submitted By: David Diehl  
Email: dave@midwesternequipment.ca  
Transaction #: 1f20e1be-3174-4272-9595-ca2d53358d6c  
Submitter's IP Address: 10.1.0.6

---

## Schedule of Prices

The Bidder hereby Bids and offers to enter into the Contract referred to and to supply and do all or any part of the Work which is set out or called for in this Bid, at the unit prices, and/or lump sums, hereinafter stated. HST is additional.

\* Denotes a "MANDATORY" field

Do not enter \$0.00 dollars unless you are providing the line item at zero dollars to the Township (unless otherwise specified).

If the line item and/or table is "NON-MANDATORY" and you are not bidding on it, leave the table and/or line item blank. Do not enter a \$0.00 dollar value.

## Tender Submission

Breakdown of Services	Unit Price *	Quantity	Cost
One, (1) New, Rear Roadside Flail Mower	\$18,899.0000	1	\$ 18,899.00
Delivery, government fees, licensing and all other dealer charges	\$0.0000	1	\$ 0.00
Subtotal:			\$ 18,899.00

## Summary Table

Bid Form	Amount
Tender Submission	\$ 18,899.00
HST (13%)	\$ 2,456.87
Total Contract Amount:	\$ 21,355.87

## Specifications

# Specifications

#	Description	Meets Specifications? *	Specify *	
1	Mower to be rear mounted	<input checked="" type="radio"/> Yes <input type="radio"/> No	Kubota SE2000P	*
2	Mower to be right side cut	<input checked="" type="radio"/> Yes <input type="radio"/> No	Right side	*
3	Mower to be 2026 or newer model year	<input checked="" type="radio"/> Yes <input type="radio"/> No	2026	*
4	Working Width: Mower shall have a minimum cutting width of 78.7" (2m)	<input checked="" type="radio"/> Yes <input type="radio"/> No	78.7 or 200cm	*
5	Operating Angles: Work angle ranging from -65 degrees (downwards) to +90 degrees (upwards)	<input checked="" type="radio"/> Yes <input type="radio"/> No	-65 downward, +90 vertical	*
6	PTO Speed: 540RPM	<input checked="" type="radio"/> Yes <input type="radio"/> No	540	*
7	Rotor Diameter: 450mm (approximately 17.7")	<input checked="" type="radio"/> Yes <input type="radio"/> No	cutting diameter 17.7 inches, 450cm	*
8	Rotor Speed: 1858RPM	<input checked="" type="radio"/> Yes <input type="radio"/> No	1996rpm	*
9	Weight: Approximately 870kg (1918lbs)	<input checked="" type="radio"/> Yes <input type="radio"/> No	1984lbs or 900kgs	*
10	Hitch Type: 3-point hitch - Cat I/II Hitch	<input checked="" type="radio"/> Yes <input type="radio"/> No	3pt and cat 1/11	*
11	Offset ability: Hydraulic pivoting (multi-tilt) allows for a significant offset for ditch maintenance	<input checked="" type="radio"/> Yes <input type="radio"/> No	47.2inches , 1200 mm	*
12	Horsepower Requirement: Designed for operation with a 70-130HP PTO Output	<input checked="" type="radio"/> Yes <input type="radio"/> No	70hp to 130hp	*
13	Transmission: Gearbox with integrated freewheel (rated up to 150 HP) with 5-belt drive	<input checked="" type="radio"/> Yes <input type="radio"/> No	5 belt and 70-130hp	*
14	Rotor Technology: High-speed rotary with heavy-duty hammers (13 per meter)	<input checked="" type="radio"/> Yes <input type="radio"/> No	14/meter	*
15	Roller: Standard 195mm (7.7") diameter rear roller with self-cleaning capabilities and bearing protection.	<input checked="" type="radio"/> Yes <input type="radio"/> No	diameter 7.7 inches, 195mm self cleaning	*
16	Safety & Durability: Features a double skin frame for increased life and hydraulic accumulators to prevent damage upon obstacle collision.	<input checked="" type="radio"/> Yes <input type="radio"/> No	double skin standard	*

## Documents

It is your responsibility to make sure the uploaded file(s) is/are not defective or corrupted and are able to be opened and viewed by the Township. If the attached file(s) cannot be opened or viewed, your Bid Call Document may be rejected.

- [References](#) - KCL\_Flail\_Mower\_Chopper\_SE\_Series\_Brochure\_EN\_Web.pdf - Friday May 29, 2026 13:48:36

# Addenda, Terms and Conditions

The Bidder hereby acknowledges and agrees:

1. To provide all goods, services and construction, as more specifically set out and in accordance with the Township's Bid Call Document, including but not limited to the scope of work, specifications, drawings, Addenda (if issued by the Township), the terms and conditions, etc. stated therein, which are expressly acknowledged and made part of this Contract.
2. This Bid is made without any connections, knowledge, comparison of figures or arrangements with any other company, firm or person making a Bid for the same Work and is in all respects fair and without collusion or fraud.
3. I/WE do hereby Bid and offer to enter into a Contract to do all the Work as specified in the Bid Call Document(s) which shall include all costs but not limited to; freight, duty, currency, etc. in accordance with the prices and terms as submitted by the Bidder herein.
4. If I/WE withdraw this Bid before the formal Contract is executed by the Awarded Bidder for the said Work or Ninety (90) Calendar Days, whichever event first occurs, the amount of the Bid Deposit accompanying this Bid (if applicable to this bid) shall be forfeited to the Township.
5. If the Bid is accepted, I/WE agree to furnish all required documentation, as required by the Bid Call Document(s) within Ten (10) Calendar Days after notification of Award.
6. I/We acknowledge and agree that any issued Addendum/Addenda forms part of the Bid Call Document.

I/WE (including any related or affiliated entities and any principal thereof) have no unresolved litigation with the Township.

I/WE agree to be bound by the terms and conditions and have authority to bind the Corporation and submit this Bid on behalf of the Bidder. - Dave Diehl, Sales, Midwestern Equipment (Listowel) Ltd  
The bidder shall declare any potential conflict of interest that could arise from bidding on this bid. Do you have a potential conflict of interest?  Yes  No

The Bidder acknowledges and agrees that the addendum/addenda below form part of the Bid Document

Please check the box in the column "I have reviewed this addendum" below to acknowledge each of the addenda.

File Name	I have reviewed the below addendum and attachments (if applicable)	Pages
There have not been any addenda issued for this bid.		



For Earth, For Life  
**Kubota**

**SE**

**KUBOTA CHOPPERS**

**SE2000/SE2000P/  
SE3000/SE4000**



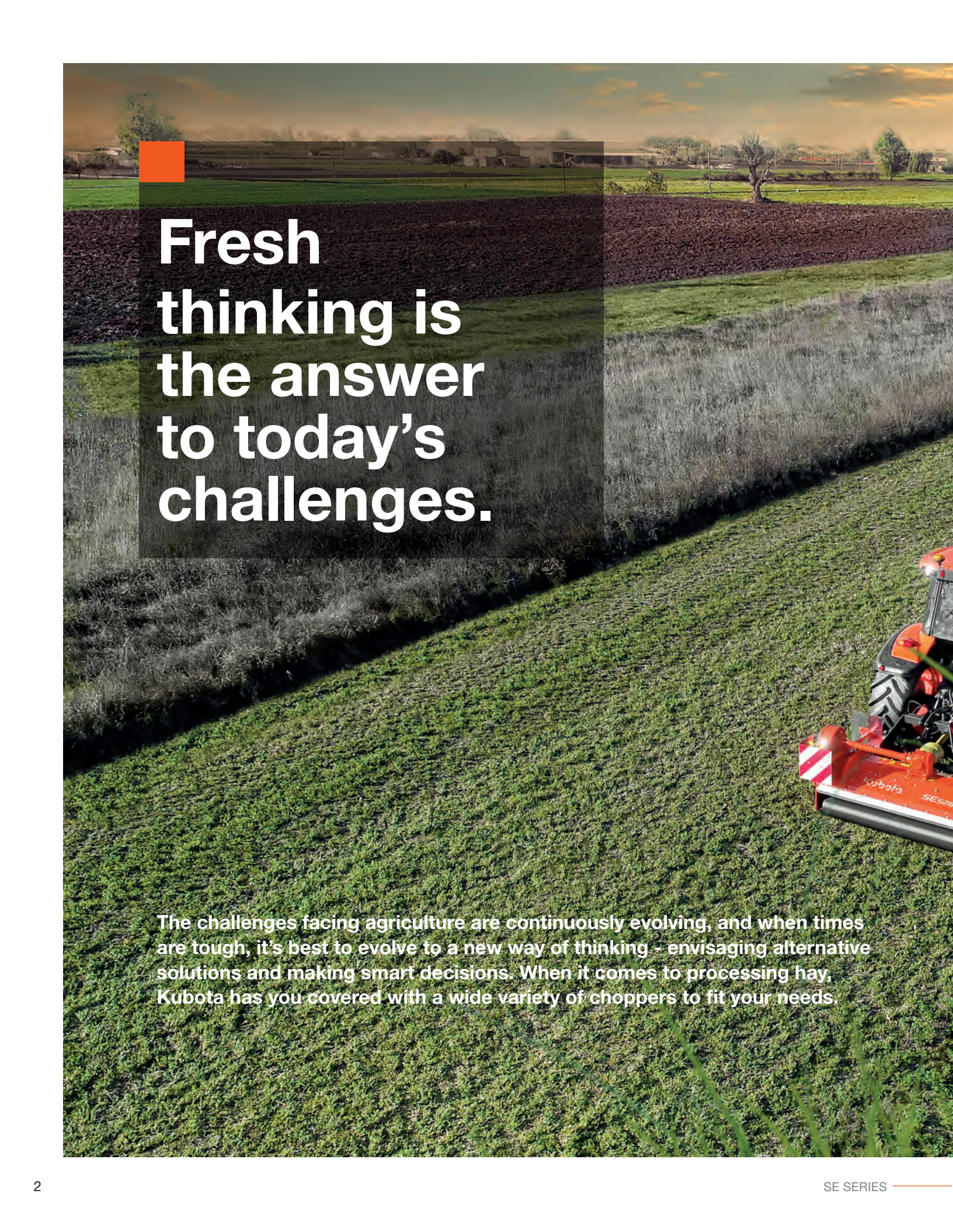

# Fresh thinking is the answer to today's challenges.

The challenges facing agriculture are continuously evolving, and when times are tough, it's best to evolve to a new way of thinking - envisaging alternative solutions and making smart decisions. When it comes to processing hay, Kubota has you covered with a wide variety of choppers to fit your needs.





# SE2000-4000: versatile, reliable and efficient

The extensive range of Kubota choppers ensures there is a model to suit every operating requirement. Each model provides great results in a wide variety of conditions. All models are constructed with a robust gearbox and rugged “V” belt transmission. A high strength body with double plating in critical areas provides further reassurance. A combination of precision engineered rotor shafts and hard wearing blades ensure reliable operation, while keeping maintenance requirements to a minimum.



### SE2000 series

Side pivoting choppers for road maintenance with working widths from 5'1"-6'6" (1.55-2.00m).

### SE2000P series

Side pivoting choppers for road maintenance with working widths from 6'6"-8'2" (2.00-2.50m).



**SE3000 series**

Choppers for green areas and vineyards with working widths from 5'1"-8'2" (1.55-2.50m).

**SE4000 series**

Multipurpose light choppers with working widths from 7'7"-10'7" (2.35-3.25m).



SE2000

# Efficient working: in all conditions

The Kubota SE2000 series is a new multipurpose chopper for road maintenance, clearing out field edges, ditches and hedges. In addition, the SE2000 series shows versatility in operation on grass, light wood and bushes thus being ideal for maintenance of parks, gardens and road sides.



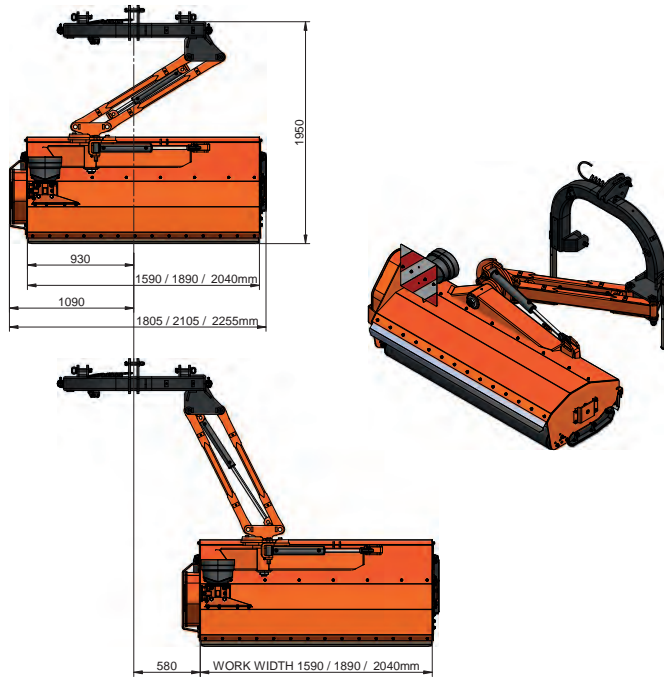

**Offset articulation**

Different offset positions can be reached by different working widths. Versatile in all conditions due to extremely efficient articulation (-65° & +90°).

**Frame**

Solid construction, heavily protected and reinforced with double skin as standard.

**Rotor**

High performance rotor with fast rotation speed, combined with large number of hammer blades (13 per meter) ensure superb chopping performance in all conditions. (universal or rock blades also optionally available).

**Transmission**

Gearbox with freewheel inside and four belts with automatic tensioner ensures smooth and reliable power transmission to the rotor.

**Roller**

Standard 7.7" (195mm) diameter roller with integrated bearings and easy cutting height adjustment.



Maximum versatility - Cutting horizontal.



Vertical.



Banks down to an angle of -65 degrees.



# More offset: more versatility

**Due to the possibility of different working angle positions, the SE2000P series is a highly versatile solution for farm and road maintenance purposes. Compact but robust it offers superb manoeuvrability and provides a high level of reliability.**

## **Compact and easy**

Compared to the standard SE2000 chopper, the plus version offers greater offset 49.4" (1255mm) and reaches positions and working angles impossible to get to with other machines. In addition the SE2000P can be combined with a front mounted chopper (SE4000 series), to maximise working width.

## **Lateral transmission**

Power transmission by gearbox with integrated freewheel (up to 150hp) and five belts which incorporate an automatic tensioner, provide stable rotor speed even when working in tough conditions. A PTO shaft with wide angle joint is fitted as standard equipment.

## **Robust and guarded**

Main frame and parallelogram articulation designed for intensive use and extreme demanding conditions; heavily tested in Kverneland Group Klepp laboratory to ensure reliable and long working life. Gearbox and transmission are protected against misuse during operation.



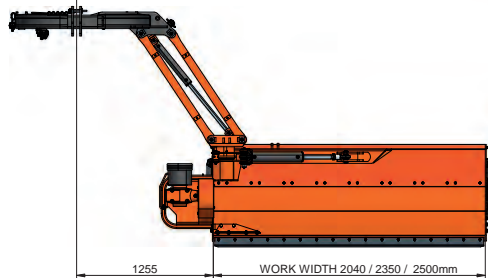
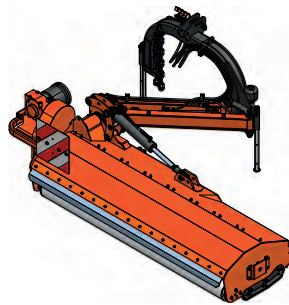
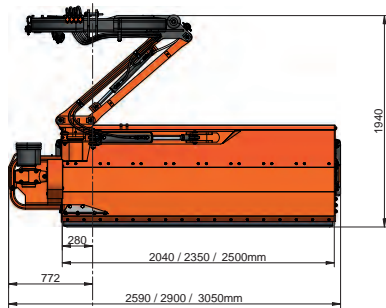

**Offset articulation**

Different offset positions can be reached by different working widths. Versatile in all conditions due to extremely efficient articulation (-65° & +90°).



# Unmatched: efficient and durable

The Kubota SE3000 Chopper is a compact and heavy duty machine for moderately demanding jobs in soft and top fruit orchards, vineyards and light undergrowth. It is also equally at home tidying pasture and other grass fields, chopping straw and stubble.



### Compact heavy duty machine

Due to its rugged construction the SE3000 series ensures a long lifetime with minimal maintenance. Adjustable headstock offset up to 19.7" (500mm) gives added versatility for reaching under fruit trees and safer working close to the edges of drainage channels.

As an option, hydraulic adjustment of the offset can be specified. In addition the standard roller and skids support the chopper and provide a consistent working height.

The design of the SE3000 series is modern and versatile; the latest generation rotor can be equipped with different types of blades, making them adaptable to most conditions. Highest rotor speeds (2160rpm) in combination with a counterknife and a double skin, guarantee an excellent shredding effect with minimal power requirement.



The Kubota SE3000 series can be equipped with rake tines to improve chopping on prunings.



A 6.3" (160mm) diameter roller with an adjustable scraper is fitted as standard equipment and ensures correct field performance.



# Multi-purpose: Front, rear or offset

**Multi-purpose - for chopping grass, pasture, set-aside land and stubble. A strong double headstock allows mounting the machine in front or behind the tractor. Together with the hydraulic offset feature, it gives multi purpose versatility for nearly all conditions e.g. clearing out field edges, orchards, road edges. All SE Choppers come standard with hammer blades.**

## Hydraulic Offset

Ideal for clearing out field edges. Versatile use also for road maintenance. The precisely aligned offset frame machined after the welding process ensures strong and reliable guidance.

Greasable nylon bushes ensure a long lifetime.



## Auto-alignment

The central gearbox fitted into the headstock ensures that the pto-shaft remains at the same angle in all working positions. Even on max. 19.7" (500mm) offset the pto angle does not change. This guarantees a smooth drive, reduced wear and a longer lifetime of the pto shaft and the whole driveline (crosses and yokes).

## Rear roller

Standard equipment for reliable depth control in all conditions. Ø 6.3" (160mm) with 1.8" (45mm) bearing hub and greasable ball bearings. Replaceable integrated bearing housing. Roller interchangeable with skids.





**Headstock**

The heavy duty headstock is well proven with the design taken from the Kubota Power Harrow range.



**Lateral Driven**

Drive by five VX type V-belts running on invertible pulleys which allows adaptation for 540 or 1000 rpm drive. Idler wheel with automatic tensioner spring always ensures stable and low wear on belt drive.



**Counter Knives and Double Skin**

One standard U-counter knife. A second U-counter knife is available (optional equipment) for more intense shredding and heavy conditions. Also combinable with double skin.



Hammer blades

# Technical data

Model	SE2000			SE2000P			
		Side Pivoting Choppers			Side Pivoting Choppers		
<b>Dimensions &amp; Weight</b>							
Working width	inch (cm)	61 (155)	72.8 (185)	78.7 (200)	78.7 (200)	90.6 (230)	98.4 (250)
Transport width	inch (cm)	70.9 (180)	82.7 (210)	88.6 (225)	100.4 (255)	112 (285)	120 (305)
Weight	lbs (kg)	1631 (740)	1720 (780)	1808 (820)	1984 (900)	2116 (960)	2172 (985)
<b>Attachment to tractor</b>							
Pto input speed	(rpm)	540			540		
Min-Max. power requirem.	(hp)	45 - 100			70 - 130		
<b>Operation</b>							
No. of universal blades		40	48	52	52	60	64
No. of hammer blades		20	24	26	26	30	32
Rotor speed	(rpm)	1800			1858		
Blade tip speed	(m/s)	43			44		
Rotor shaft diameter	inch (mm)	2 (50)			2 (50)		
Rotor diameter	inch (mm)	6.7 (169)			6.7 (169)		
Cutting diameter	inch (mm)	17.8 (452)			17.8 (452)		
No. of belts		5			5		
Belt tensioner		automatic			automatic		
<b>Equipment</b>							
Offset	inch (mm)	22.8 (580)			49.2 (1250)		
Rear roller	inch (mm)	7.7 (195) ●			7.7 (195) ●		
Rear wheels		-	-	-	-	-	-
Skids		●	●	●	●	●	●
I counter knife		●	●	●	●	●	●
II counter knife		○	○	○	○	○	○
Double skin		●	●	●	●	●	●

- not available   ○ option   ● standard

Model	SE2000			SE2000P			
		Side Pivoting Choppers			Side Pivoting Choppers		
<b>Blades</b>							
Hammer blades		●			●		

SE3000					SE4000			
Choppers for Green Area and Vineyards					Multipurpose choppers			

61 (155)	72.8 (185)	78.7 (200)	90.6 (230)	98.4 (250)	92.5 (235)	110.2 (280)	128 (325)	
69.7 (177)	81.5 (207)	87.4 (222)	99.2 (252)	107 (272)	100.4 (255)	118.1 (300)	96.5 (345)	
1047 (475)	1191 (540)	1261 (572)	1367 (620)	1444 (655)	1903 (863)	2161 (980)	2381 (1080)	

540					540 or 1000			
35 - 80					60 - 140			

40	48	52	60	64	40	48	56	
20	24	26	30	32	20	24	28	
2160					1730 - 1828			
51					46 - 48			
2 (50)					2.4 (60)			
6.7 (169)					8.7 (220)			
17.8 (452)					19.8 (503)			
5					5			
automatic					automatic			

19.7 (500)					19.7 (500)			
6.3 (160) ●					7.7 (195) ●			
-	-	-	-	-	○	○	○	
●	●	●	●	●	●	●	●	
●	●	●	●	●	●	●	●	
○	○	○	○	○	○	○	○	
●	●	●	●	●	○	○	○	

SE3000					SE4000			
Choppers for Green Area and Vineyards					Multipurpose choppers			

●					●			
---	--	--	--	--	---	--	--	--

*Descriptions, specifications, images, colours and accessories contained in this brochure are based on information believed to be correct at the time this publication was approved for printing. Although descriptions, specifications, images, colours and accessories are believed to be correct, accuracy cannot be guaranteed. Errors and omissions excepted. Kubota Canada Ltd. reserves the right to change the stated specifications, colours and accessories without notice. Some items shown may be optional and some products shown may not be available at all dealerships. This brochure is for informational purposes only. To the fullest extent permitted by law, Kubota disclaims all representations and warranties, express or implied, as well as any liability from the use of this brochure. For complete warranty, safety and product information, consult your local Kubota dealer and the operator's manual. Power (HP/KW) and other specifications are based on various standards or recommended practices. For your safety, Kubota strongly recommends the use of a Rollover Protective Structure (ROPS) and seat belt in almost all applications. This brochure is intended for the Canadian market only. For information regarding Kubota products or services outside these areas, see Kubota Corporation's global website. Kubota does not provide parts, warranty or service for any product which is re-sold or retailed in any country other than the country for which the product(s) were designed or manufactured.*

©2023 Kubota Canada Ltd.



## **KUBOTA CANADA LTD.**

Kubota Canada Ltd.

Head office: 1155 Kubota Drive, Pickering, Ontario, L1X 0H4

Visit our web site at: [www.kubota.ca](http://www.kubota.ca)

SE2000/SE4000EN-01. Printed 04.2023



# Staff Report to Council

**Report From:** Caitlin Gillis, CAO/Clerk  
**Meeting Date:** June 16, 2026  
**Report:** ADM-2026-10  
Parkland Funds – Fordwich Park Board

## Recommendation:

That Howick Council authorize the transfer of \$18,000.00 from Parkland Reserves to the Fordwich Park Board for repairs and resurfacing of the Tennis Court.

## Report Overview

<b>Purpose of Report</b>	For Approval
<b>Council Priority Alignment</b>	Safe & Reliable Infrastructure Welcoming & Vibrant Community
<b>Consultations</b>	<b>Justine MacDonald, Chair, Fordwich Park Board</b>
<b>Attachment(s) to Report</b>	Quotes for Fordwich Park Board Tennis Court Refurbishment

## Report Highlights

- \$18,000 of cash-in-lieu of parkland funds were collected from the Fordwich North Estates Plan of Subdivision. Instead of creating a new park in Fordwich, township staff proposed that the funds be put toward the existing Fordwich Ball Park for future repairs and upgrades.

## Context and Background

A condition of the Fordwich North Estates Subdivision Agreement was the payment of \$750 per created lot as cash-in-lieu of parkland. With 24 newly created lots, a payment of

\$18,000 was received from the developer in 2025 when the Plan of Subdivision was approved and registered.

## **Discussion and Staff Recommendation(s)**

As outlined in the *Planning Act, 1990*, as amended, parkland funds must be used for the acquisition of land to be used for park or other public recreational purposes, including the erection, improvement or repair of buildings and the acquisition of machinery for park or other public recreational purposes.

Under Section 42(16.1) of the Planning Act, beginning in 2023 and in each calendar year thereafter, a municipality shall spend or allocate at least 60 per cent of the monies that are in the (parkland) special account at the beginning of the year.

Fordwich Parks Board continues to fundraise for improvements to the Fordwich Ball Park. In 2026, a swing set was added to the playground equipment due to a generous donation from the Howick Optimist Club. The Board has held several lottery licences in 2026, including a duck race and 50/50 draw to assist in raising funds for park improvements.

The Fordwich Parks Board has provided quotes for the repair and refurbishment of the tennis court as a proposal for utilizing the parkland fees that were collected for the Fordwich North Estates development.

## **Impact Analysis**

There are no financial implications for this allocation of funds, as they are currently held in the Parkland Reserve.

## **Linkages**

[Quotes for Tennis Court Repairs and Refurbishment, Fordwich Park Board](#)

---

**Respectfully submitted,**

**Caitlin Gillis, Chief Administrative Officer/Clerk**



# QUOTATION

2102 Glenhampton Rd.  
Oakville ON.  
289 813 7608

QUOTE#	DATE
26031	May 25th 2026

**TO**

Jeni MacEwen

DESCRIPTION OF WORK				
Tennis Court Crack Repair, Resurfacing, and Line Installation				
ITEMIZED COSTS	QTY	UNITS	UNIT PRICE	AMOUNT
<b>Surfacing Preparation</b> Power wash to remove all debris from surface  <b>Crack Repair</b> Fill cracks with SportMaster Patch Binder Install Riteway crack repair system as needed on surface cracks  <b>Sports Surfacing</b> Install two coats of SportMaster Resurfacers. Install two coats of SportMaster Colorplus (2 colours)  <b>Lines</b> Install white 2" wide tennis lines. Install 2' wide pickleball lines (colour tbd)				
<i>Thank you for the opportunity!</i>				<b>\$16,482.00</b>

Note: Court colours (2) selected by client.  
 Brite Red, Tournament Purple and Orange pigments extra.  
**Water and hydro access minimum 12hrs/day, 7days/week including public holidays.**  
 MSDS for products available upon request.  
 Quotation does not include HST.



# QUOTATION

2102 Glenhampton Rd.  
Oakville ON.  
289 813 7608

QUOTE#	DATE
26031	May 25th 2026

**TO**  
Jeni MacEwen

DESCRIPTION OF WORK				
Tennis Court Crack Repair, Resurfacing, and Line Installation				
ITEMIZED COSTS	QTY	UNITS	UNIT PRICE	AMOUNT
<b>Surfacing Preparation</b> Power wash to remove all debris from surface  <b>Crack Repair</b> Fill cracks with SportMaster Patch Binder Install Riteway crack repair system as needed on surface cracks  <b>Fiberglass Mesh Install</b> Supply and installation of fiberglass mesh layer  <b>Sports Surfacing</b> Install two coats of SportMaster Resurfacer. Install two coats of SportMaster Colorplus (2 colours)  <b>Lines</b> Install white 2" wide tennis lines. Install 2' wide pickleball lines (colour tbd)				
<i>Thank you for the opportunity!</i>				<b>\$20,482.00</b>

Note: Court colours (2) selected by client.  
 Brite Red, Tournament Purple and Orange pigments extra.  
**Water and hydro access minimum 12hrs/day, 7days/week including public holidays.**  
 MSDS for products available upon request.  
 Quotation does not include HST.



1450910 ONTARIO LIMITED DBA Sport Court Ontario and All Sport Construction Group  
 5807 Sideroad 30  
 Utopia ON L0M 1T0  
 4167881798  
 info@sportcourt.ca  
 www.sportcourt.ca  
 HST (ON) Registration No.: 882053416RT0001  
 Business Number 882053416 RT0001

# Estimate

## ADDRESS

Jenifer MacEwen  
 Fordwich Parks & Recreation Board  
 Fordwich

ESTIMATE # 7015  
 DATE 28/05/2026

DESCRIPTION	QTY	RATE	AMOUNT
ADDITIONAL SITE WORK - - a site visit is required to confirm if any additional costs would be required to resurface the court. This estimate is based on photos sent	1	0.00	0.00
Installation of SPORT MASTER COLOUR PLUS (The Official Acrylic Surfacing for USA Pickleball and USPTA) OR ACRYTECH Acrylic painted surface (The Official Acrylic Surfacing for PPA and MLP) 50 x 120 court area as per request - power blow off existing court area - power wash the court - crack filler/patch work and minor levelling of existing bird bath area, - Acrylock latex primer & sealer - installation of Acrylic Resurfacer Flex 2 coats - install 2 layers of Acrylic Colour Flex coating - colours TBD - install all painted playing lines (pickleball etc)	1	27,000.00	27,000.00
ACRYTECH Sport Patch is a 100% acrylic latex binder, that when mixed with portland cement and sand, produces a semi flexible latex concrete that is ideal for patching depressions over 1/4" deep and filling cracks larger than 3/8" wide. ACRYTECH Sport Patch is appropriate for use when applied to asphalt or concrete surfaces, or to previously coated surfaces.			
TRUCK, TRAVEL	1	1,776.00	1,776.00

Contact SPORT COURT ONTARIO 1450910 ONTARIO LIMITED to pay.  
 Signature

SUBTOTAL 28,776.00  
 HST (ON) @ 13% 3,740.88  
**TOTAL \$32,516.88**

Estimate prices may change prior to confirmation of order.  
 Payable by Etransfer to patty@sportcourt.ca, cheque payable to 1450910 Ontario Ltd,  
 Visa, MC, AMEX (2.45% service fees will be applied to CC payments)  
 If you would like to do a bank wire or pay by credit card email patty@sportcourt.ca for details.  
 Terms - 50% dep, balance on install, 5% late fees on payments over 30 days.

Howick Homecoming Meeting April 07, 2026

6:30pm-9:30pm

Attendance: Lindsay Dinsmore, Stephanie Johnson, Alyssa Van Wyk, Lynda Strong, Kirby Proper, Fay Cross, Leslie Strong, Sarah Skinn, Kristi Shepherd, Candis Fitch, Amanda Watson

Regrets: Ben Blackmore, Travis Brown, Jess Miller

### Event Updates

Howick Idol: 8 registered for the competition.

Action Item: Advertise Howick Idol again and specify that registration payments can be made online via e-transfer.

Golf Tournament: Fully registered

Fireworks: Alyssa is working with Pete King to come up with a plan for homecoming

Action: Alyssa to reach out to Driftwood to see if they would be able to help with man power and explore alternative options should the amount of fireworks intended to be purchased not be feasible for Pete to execute.

Scavenger Hunt: Will be in the June issue of What's Happening in hopes to be a "tear out" page. The Women's Institute is creating the scavenger hunt.

"Paint the Town" Decorating Contest- Submissions are due June 22nd. A committee will go around to take pictures and vote on the best three for each category. Three finalists will be announced on social media for community members to vote. Prizes for the winners.

Action Item: Steph to create one form for residential submissions and another for business submissions.

Action Item: Amanda to create a social media post for the contest

Action Item: Connect with Village Management to see if they would be able to assist with decorating the towns.

Car Show: from 12pm-4pm

Action Item: Advertise Car Show

Kids Zone: Has been booked

Chuckles the Clown- 2pm-4pm

Reptile Exhibit- 1pm-4pm

Magic Show- 1:30pm-2:00pm

Inflatables and Carnival Games- 10am-5pm

Facepainting- TBD

Basketball Grain Bin- Has been booked for the weekend

Action Item: Find sponsor/donor for a corn “sandbox”, items for a toddler town, reach out the to Fire Department to see if they would be able to donate generators, look for a fuel sponsor for the generators.

#### Wright Bloom's Fundraiser

Received approximately 120 planter orders

Action: Check in with Wright Blooms Greenhouse to do pick up at the greenhouse. Committee members will sort orders.

#### Merchandise Update

Selling Tiny Word Project Bracelets for \$15.00 each or \$40.00 for 3.

Cups are now available

Action: Logo needs to be made into SVG for screen printing for tank tops

50/50 Raffle tickets have been ordered and should be available for the Maple Syrup Festival.

Minor Hockey is holding the lottery license for 50/50 as it does not interfere with any of their fundraising events. Tickets are \$5.00 each and 5,000 tickets are printed.

Currently do not have a last order date.

Pop Ups:

Howick Homecoming has a booth at the Belmore Maple Syrup Festival on Thursday and Saturday.

Action: Ask to see if the Gorrie Hall can be used for Pop Ups and Pick Up points for Merchandise and Tickets

May 3rd- Fireman's Breakfast Pop Up Shop

Action: Alyssa to double check with Scott

#### Social Media/Marketing/Advertising

The Howick Homecoming books have been started, the print deadline to have all sponsorship material in and complete is May 4th.

Signage for each town sign is ordered.

Action Item: Committee Members to provide Ideas for the next special in the Newspaper.

- Potential: Past Parade
- Spotlight: Howick Idol, Fireworks, etc.

#### Parade

Route: Starting at 10:30am near John Wilson Electric , down main street, a right on Adelaide past Fordwich Village Nursing Home, a left on William, a left on Victoria, back to the Main Street, ending at Fordwich Estates.

Action: Advertise parade registration and the parade is through Fordwich

#### Historical Display

Will be on Sunday in the upstairs of the arena?

Action: Fay is going to reach out within her network to see if anyone would like to contribute to the exhibit

#### Transportation

Times:

- Friday 4pm-1am
- Saturday 1pm-2am
- Sunday 10am-5pm

#### Food

Food Truck Times

- Friday 4-12
- Saturday 12-7
- Sunday 11-3

Saturday Late Night Food, looking for a vendor to potentially use the foodbooth. Served from 8pm-1am.

Action Item: Alyssa going to reach out to Frosty Queen to see if they have interest.

Fay- Will set up a table with Cotton Candy and Sweets to sell on Saturday.

**Next Meeting Monday April 27th- 6:30pm**

## Agenda/Minutes

Attendees: Steph Johnson, Lindsay Dinsmore, Alyssa Van Wyk, Kirby Proper, Sarah Skinn, Ben Blackmore, Faye Cross, Kristy Shepherd, Lynda Strong, Leslie Strong, Candis Fitch

Regrets: Amanda Watson, Thomas Wheildon

1. Fairmont Security- Thomas Wheildon
  - Couldn't make it, will come to next meeting
  
2. Committee Updates
  - Marketing/Advertising/Social Media- Alyssa
    - i. Books are being printed, first round is being dropped off to the school this week
    - ii. Lawn signs being delivered
    - iii. Working on a prize for a social media (potentially 4 tickets for African Lion Safari from radio station)
    - iv. Blackburn requesting event tickets for giveaways (additional airtime coverage)
    - v. 10 dance tickets will go to Blackburn for week's worth of giveaways
    - vi. Emcee for opening ceremonies?
      1. Short opening ceremonies, MC not necessary
  
  - Food- Jess
    - i. Jess to be in touch with food vendors re: HPPH requirements
  - Entertainment/Kids Zone- Amanda
    - i. Collecting outdoor kids toys (step2, cozy coupes, cottages, etc.)
    - ii. Face painters, see if we can get more?
  - Clothing and Merchandise- Sarah and Kristy
    - i. Cut off date for orders will be June 15
  - Volunteers- Kirby
    - i. Howick mutual bartending
    - ii. Steph has 2 folks for Friday afternoon
    - iii. Volunteer meeting zone, volunteer identification
    - iv. Lanyards to be ordered
    - v. Volunteer outreach for "end of night"
    - vi. Gorrie Bible Fellowship interested in helping out at Friday Night dinner
  
3. Event Registrations- euchre/cornhole/trivia
  - Euchre
    - i. Will be mixed, no cut-off for registration, prize for 2 people, \$10/team
    - ii. Steph make a form
  - Fordwich Parks Board/Cornhole
    - i. Pre-registration required
    - ii. Need 2-3 volunteers (from parks board)
  
4. Meal tickets
  - Rough numbers a week prior for T&M

- Steph to contact Brussels Legion for final cut-off
- Food trucks friday night, saturday during the day,

#### 5. Golf Tournament

- What is needed
- Tickets/merchandise set up?
  - i. Print off merch order
  - ii. 50/50 tickets

#### 6. Karaoke/Wing event - June 20

- Help(at door,merchandise set up)
- Bar-what to serve
  - i. Lynda meeting with Brady Friday to finalize plans/layout
  - ii. Will be on the arena floor
  - iii. People's choice on June 20th
    1. T-shirt and a cup
  - iv. Wings 6-8, singing starting at 8
  - v. 50/50 and donation entry at lobby, merch on floor
  - vi. Wristbands for minors
  - vii. Dillons, coors slushies,
  - viii. Kids drink available

#### 7. Parade- Ben

- Route
  - Ben will be driving with Scott to finalize the route
- Parade judges for winning float categories
- How else can the committee help?
  - Ben to send out email with potential requests for parade assistance

#### 8. Other items

- Bow night help
  - i. 3 rolls of each colour
  - ii. 25 bows to each village
  - iii. Alyssa on refreshment duty
- flower pickup help
  - i. Steph to go to Wright Blooms
- Set up before event weekend
- Fencing set up(porta potties)(grounds)
- Porta potties location
- Bar setup

# Belmore Arena Board Meeting MINUTES March 16, 2026

*Time: 8:00pm Location: Lounge, Belmore Community Centre*

**Board Members:** Jeremy Underwood (*Chair*), Jenn Van Dyk (*Treasurer*), Kim Harris (*Rentals/Event Coordinator*), Warren Weber (*Ice Rentals*), Kyra Wright (*Grants*), Brett McPherson (*Parks & Rec*), Marvin Grimes (*Howick Rep*), Mark Ireland (*South Bruce Rep*), Chris Inglis (*Catering*), Ian Inglis (*Director at Large*), Jamie McCallum (*Morris-Turnberry Rep*), Randy Scott (*Vice Chair*), Lorne Underwood (*Chamber Rep*), Wanda Inglis (*Director at Large*), Heidi Dupuis (*Figure Skating*), Dave Eadie (*Curling*), Lindsay Underwood (*Communications & Programming*), Darlene Loos (*Secretary*)

**Attendees:** Jeremy Underwood, Jenn Van Dyk, Kim Harris, Warren Weber, Brett McPherson, Marvin Grimes, Randy Scott, Kyra Wright, Lorne Underwood, Wanda Inglis, Heidi Dupuis

**Guests:** Paul Inglis

**Regrets:** Mark Ireland (*South Bruce Rep*), Chris Inglis (*Catering*), Ian Inglis (*Director at Large*), Jamie McCallum (*Morris-Turnberry Rep*),

**Secretary/Recorder:** Darlene Loos

<i>Time</i>	<i>ITEM</i>	<i>(Discussion, Approval, Information Sharing)</i>	<i>Meeting Notes/Action Items</i>
8:00pm	<b>Call to Order</b> <b>Approval of March 16, 2026 Agenda</b> - <i>Jeremy Underwood</i>		Meeting called to order: 8:02pm Any Additions to Agenda? Update from Terms of Reference Committee Motion to approve agenda by Lorne Underwood, 2 <sup>nd</sup> Warren Weber. Carried
8:02pm	<b>Approve Previous Mtg Minutes February 16, 2026</b> <span style="background-color: cyan;">attached</span> - <i>Board</i>		Motion to approve by Marvin Grimes, 2 <sup>nd</sup> Brett McPherson. Carried

## Agenda Items

8:03	<b>Update Previous Action Items</b> (below agenda items) - <i>Jeremy Underwood</i>	<b>Standing</b>	Review action Items below.
8:10	<b>Correspondence</b> - <i>All</i>	<b>Standing</b>	None.
8:20	<b>2027 Rental Rate Increase</b> - <i>Kim Harris/Jenn V</i>	<b>Discussion</b>	Jenn reached out to Howick Twp to see if they are updating their fees bylaw before the fall. No response back.
8:25	<b>Grants Update</b> - <i>Kyra Wright</i>	<b>Standing</b>	Grant has been submitted in conjunction with Howick Township.
8:35	<b>Treasurer's Report</b> - <i>Jenn VanDyk</i>	<b>Standing</b>	Motion to pay bills \$10,994.79 by Jenn VanDyk. 2 <sup>nd</sup> by Randy Scott. Carried
8:45	<b>Belmore Catering</b> - <i>Chris Inglis/Kim Harris</i>	<b>Committee Report</b>	Catering has been very busy.
8:55	<b>General Maintenance</b> - <i>Jeremy Underwood/Warren Weber</i>	<b>Committee Report</b>	Tap in the kitchen to be fixed. Water Bottle fill in dressing room is not running cold. They are running warm. Motion tap not working in dressing room 1.

			<p>Post broken – glass and post in the refs room. Will add to list for summer work.</p> <p>Centre chandelier in hall is broken. There is an extra we can replace once rentals slow down.</p>
9:05	<b>Parks Board</b> - <i>Brett McPherson</i>	<b>Committee Report</b>	Nothing to report.
9:15	<b>Rentals - Hall &amp; Lounge</b> - <i>Kim Harris</i>	<b>Committee Report</b>	<p>Microphone got purchased. Good reviews from renters.</p> <p>Skating Club's Carnival was cancelled last weekend, rescheduled to weekend of March 21<sup>st</sup>. They will use the lounge to take pictures and gather after the carnival.</p>
9:25	<b>Ice Rentals &amp; Installation</b> - <i>Warren Weber</i>	<b>Committee Report</b>	February 125 rental hours. Up 30 hours from last year.
9:35	<b>Belmore Curling</b> - <i>Dave Eadie</i>	<b>Committee Report</b>	<p>Things are going really well.</p> <p>Bonspiels well attended.</p>
9:45	<b>Belmore Figure Skating</b> - <i>Heidi Dupuis, Andrea Warwick</i>	<b>Committee Report</b>	Skating Club's Carnival was cancelled last weekend, rescheduled to weekend of March 21 <sup>st</sup> .
9:55	<b>South Bruce</b> - <i>Mark Ireland</i>	<b>Committee Report</b>	Absent
10:00	<b>Morris-Turnberry</b> - <i>Jamie McCallum</i>	<b>Committee Report</b>	Absent
10:05	<b>Howick</b> - <i>Marvin Grimes</i>	<b>Committee Report</b>	Nothing to report.
10:10	<b>Communication</b> - <i>Lindsay Underwood</i>	<b>Committee Report</b>	Absent
10:15	<b>Belmore Chamber of Commerce</b> - <i>Lorne Underwood / Chamber Member</i>	<b>Committee Report</b>	Would like to suggest that all groups (Figure Skating, Curling, Arena Board, etc.) have their reports audited before submitting to the Chamber for the AGM.
<b>Addition to Agenda</b>	<b>Terms of Reference Committee Update</b>	<b>Committee Report</b>	<p>Committee has a draft prepared that can be presented to the Arena Board. This to be presented to a closed session of the Arena Board. Edits will be suggested/made. Once approved will be presented in closed meeting to the 2 Municipalities.</p> <p>CAO, Mayor and Treasurers (2-3 representatives from each municipalities). Once we have agreed and 3 councils have agreed, it would be forwarded to Howick Council for review and consideration.</p> <p>There are 3 Documents that we need to be working within.</p> <ol style="list-style-type: none"> <li>1. Belmore Community Centre Operation and Maintenance Agreement</li> <li>2. Council of the Corporation of the Township of Howick</li> <li>3. Procurement Policy and Procedures</li> <li>4. Procedural Bylaw</li> </ol>

		<p>Members to review documents prior to presentation meeting. Meeting to be set outside of regular Arena Board. <b>Monday, April 27<sup>th</sup> – 7pm to 9pm.</b></p> <p><b>DARLENE TO SEND EMAIL OUT</b></p> <p>Asset Management Plan – need to have this plan in place to obtain government funding. This is a document to guide us as we move forward. If anyone would like to review a copy speak to Wanda.</p>
--	--	----------------------------------------------------------------------------------------------------------------------------------------------------------------------------------------------------------------------------------------------------------------------------------------------------------------------------------------------------------------------------------------------------------------------

**Next Meeting – April 20, 2026 at 8pm**

**Adjournment of Meeting:** 8:53PM

**Motion to adjourn by:** Warren Weber

**Previous Action Items**

<b>Lead</b>	<b>Agenda Item/Topic</b>	<b>Actions for Follow Up</b>
Jeremy/ Warren /Kim	<b>General Maintenance</b>	<p><b>20241118:</b> Glass broken along top of timekeepers’ box.</p> <p><b>20251117:</b> Outside lights at the main hall – water pools within the light fixtures. Will need to have a look and find replacement fixtures.</p> <p><b>20251117:</b> Constant drip in ladies bathroom (hall side), first sink.</p> <p>20260316: Things to be added to repair list</p> <ul style="list-style-type: none"> <li>• Tap in the kitchen to be fixed.</li> <li>• Water Bottle fill in dressing room is not running cold. They are running warm.</li> <li>• Motion tap not working in dressing room 1.</li> <li>• Post broken – glass and post in the refs room. Will add to list for summer work.</li> <li>• Centre chandelier is broken. There is an extra we can replace with once rentals slow down.</li> </ul>
Kyra	<b>Grants</b>	<p>20250818: Kyra will begin the grant application process for the Vance Grant. Will need 3 quotes for materials. Will be applying for 100% (<i>will proceed with project if receive 50% or more from the grant</i>).</p> <p>20250818: Motion made to apply for this grant through Howick.</p> <p>20260316: Grant was submitted in conjunction with Howick.</p>
Board	<b>Structural Condition Assessment</b>	20260216: Board will review report and create a To-Do List.
<b>Parking Lot</b>		
Jeremy / Brett	<b>Parks Board</b>	<p><b>20240715:</b> Willow tree in back corner needs to be taken down before it crashes down. Should do this before winter.</p> <p>20251117: suggestion to contact an arborist for work to be done in 2026.</p>
Jeremy/ Warren	<b>General Maintenance – for Summer</b>	<p>20230228:</p> <ol style="list-style-type: none"> <li>1) Brine header – preventative maintenance by 2025.</li> </ol>

		<ul style="list-style-type: none"><li>○ 20230821: Need to let Municipali.es know (in November/December) about Brine Header replacement project before their budgets are made.</li><li>○ 20231016: working on a couple of quotes for brine headers.</li><li>○ 20240617: spoke with Ben and his company should have time to repair it. Moving ahead with this.</li><li>○ 2024118: Q1-Q2 should hear whether or not we received grant money<ul style="list-style-type: none"><li>▪ If we don't receive grant, we need to put it into a budget</li></ul></li><li>○ 20250520: Jeremy will confirm with Ben if he can repair. Chamber will need to know by early June.</li></ul> <p>20250915: BRINE HEADER will be going ahead now and will be completed within a month.</p> <ul style="list-style-type: none"><li>- Will need new boards over the Curling Header. Kyra will look for Gord's drawings from a few years ago. Then Kim will ask Gord to look at it.</li></ul> <p>20251020: briner header is going in "as we speak"</p> <ul style="list-style-type: none"><li>2) Boards around the ice surface need to be replaced.</li></ul> <p><b>PUT INTO PARKING LOT</b></p>
<b>Adjournment: 8:53pm</b>		<b>Next Meeting - Monday, April 20, 2026 at 8pm</b>



## Belmore Arena Board Meeting MINUTES April 20, 2026

*Time: 8:00pm Location: Lounge, Belmore Community Centre*

**Board Members:** Jeremy Underwood (*Chair*), Jenn Van Dyk (*Treasurer*), Kim Harris (*Rentals/Event Coordinator*), Warren Weber (*Ice Rentals*), Kyra Wright (*Grants*), Brett McPherson (*Parks & Rec*), Marvin Grimes (*Howick Rep*), Mark Ireland (*South Bruce Rep*), Chris Inglis (*Catering*), Ian Inglis (*Director at Large*), Jamie McCallum (*Morris-Turnberry Rep*), Randy Scott (*Vice Chair*), Lorne Underwood (*Chamber Rep*), Wanda Inglis (*Director at Large*), Heidi Dupuis (*Figure Skating*), Dave Eadie (*Curling*), Lindsay Underwood (*Communications & Programming*), Darlene Loos (*Secretary*)

**Attendees:** Jeremy, Jenn, Warren, Brett, Marvin, Mark, Chris, Ian, Jamie, Wanda, Lindsay

**Guests:**

**Regrets:** Darlene Loos, Kim Harris, Randy Scott, Heidi Dupuis, Kyra Wright, Dave Eadie

**Secretary/Recorder:** Jenn (*in Darlene's absence*)

<i>Time</i>	<i>ITEM</i>	<i>(Discussion, Approval, Information Sharing)</i>	<i>Meeting Notes/Action Items</i>
8:00pm	<b>Call to Order</b> <b>Approval of April 20, 2026 Agenda</b> - <i>Jeremy Underwood</i>		Meeting called to order: Any Additions to Agenda? No Motion to approve agenda: Ian, Chris
8:02pm	<b>Approve Previous Mtg Minutes March 16, 2026 (attached)</b> - <i>Board</i>		Motion to approve: Marvin, Warren

### Agenda Items

8:03	<b>Update Previous Action Items (below agenda items)</b> - <i>Jeremy Underwood</i>	<b>Standing</b>	Review action Items below.
8:10	<b>Maple Syrup Festival Update</b>	<b>Information Sharing</b>	Busy couple days.
8:20	<b>Correspondence</b> - <i>All</i>	<b>Standing</b>	Jeremy – resigning as chair, a replacement needs to be found to take on the role of chairperson. Remaining as maintenance arena board member. Jeremy will speak to Randy and ask if he is willing to step into the Chair position. Lindsay – received a request that star skater achievements banner be put back up or displayed somewhere within the arena/building. Board agreed to put banner up.
8:25	<b>Grants Update</b> - <i>Kyra Wright</i>	<b>Standing</b>	Kyra sent an update in her absence: would like to know a plan for the board replacements to get organized and pictures with donors (to put online for recognition). Jeremy reported that an application was sent to Bruce Power to request donation for the boards replacement as well. Suggestion to modify the boards opening at the curling club end (that's taken out for Maple Syrup Festival), Board agrees to make modifications. Materials will get ordered (Ian) and work to start next "rainy day".

8:35	<b>Treasurer's Report</b> - <i>Jenn VanDyk</i>	<b>Standing</b>	Total bills to be paid for April: \$11,786.36 Motion to pay bills as listed: Jenn, Jamie
8:45	<b>Belmore Catering</b> - <i>Chris Inglis/Kim Harris</i>	<b>Committee Report</b>	Couple weddings coming up, quieter summer which is okay.
8:55	<b>General Maintenance</b> - <i>Jeremy Underwood/Warren Weber</i>	<b>Committee Report</b>	Plan to work away at items within the structural assessment through the summer.
9:05	<b>Parks Board</b> - <i>Brett McPherson</i>	<b>Committee Report</b>	Thinking about doing a cleaning day. Requested to purchase a load of topsoil. Board approved. Grass cutting – asked if someone knows of an interested party to cut grass. (members requested to ask Jackson again this year)
9:15	<b>Rentals - Hall &amp; Lounge</b> - <i>Kim Harris</i>	<b>Committee Report</b>	Update sent by Kim: - what would be best to use as an arena floor rental contract – Board suggested using ice rental contract as a starting point and modify where needed - pickleball requested that if numbers are not as high as expected and only use half of surface can rent be lesser charge – consensus of Board is to see how the year goes and open to Pickleball to come to a meeting if they are struggling
9:25	<b>Ice Rentals &amp; Installation</b> - <i>Warren Weber</i>	<b>Committee Report</b>	Great ice year. 73 hours more than last year. Plant ran in 2024 for 15.5hrs a day, 2025 for 14.5hrs a day, 2026 for 11.57 hrs a day
9:35	<b>Belmore Curling</b> - <i>Dave Eadie</i>	<b>Committee Report</b>	<b>New curling representative will be Don Ross</b>
9:45	<b>Belmore Figure Skating</b> - <i>Heidi Dupuis, Andrea Warwick</i>	<b>Committee Report</b>	Planning to continue with Saturday skating and have a new coach secured for next season
9:50	<b>Pickleball Club</b>	<b>Committee Report</b>	NA
9:55	<b>South Bruce</b> - <i>Mark Ireland</i>	<b>Committee Report</b>	None
10:00	<b>Morris-Turnberry</b> - <i>Jamie McCallum</i>	<b>Committee Report</b>	None
10:05	<b>Howick</b> - <i>Marvin Grimes</i>	<b>Committee Report</b>	None
10:10	<b>Communication</b> - <i>Lindsay Underwood</i>	<b>Committee Report</b>	None
10:15	<b>Belmore Chamber of Commerce</b> - <i>Lorne Underwood / Chamber Member</i>	<b>Committee Report</b>	Abe: Chamber asking about any upcoming funding requests that may be made: brine header finishing touches (final bill), possibly rebuilding the compressor and operating funds.
10:20	<b>Terms of Reference Committee Update</b>	<b>Committee Report</b>	<b>Reminder of Special Meeting:</b> Closed Session of the Arena Board <b>Monday, April 27<sup>th</sup> – 7pm to 9pm.</b>

Committee has a draft Terms of Reference prepared to present the Arena Board. This to be presented to a closed session of the Arena Board. Edits will be suggested/made. Once approved will be presented in closed meeting to the 2 Municipalities.

CAO, Mayor and Treasurers (2-3 representatives from each municipalities). Once we have agreed and 3 councils have agreed, it would be forwarded to Howick Council for review and consideration.

There are 3 Documents that we need to be working within.

- 1. Belmore Community Centre Operation and Maintenance Agreement
- 2. Council of the Corporation of the Township of Howick
- 3. Procurement Policy and Procedures
- 4. Procedural Bylaw

Members to review documents prior to presentation meeting. Meeting to be set outside of regular Arena Board.

Asset Management Plan – need to have this plan in place to obtain government funding. This is a document to guide us as we move forward. If anyone would like to review a copy speak to Wanda.

Copies of policies etc available for anyone who wasn't here last month. Committee met with Caitlin last week to discuss closed meeting requirements. Closed meeting – to review roles, procedures and how it affects the boards role, no motions will be made at the meeting, committee will note questions and comments. 3.1 education or training purpose of having a closed meeting.

Closed meeting agenda and draft will be sent out to arena board this week in preparation for meeting.

Final draft document will be presented at next meeting (May) for public review, then motion to take to councils. Hopefully in June document will go to councils.

Asset management plan – meet with Amy to help highlight and info that needs to go back and forth btw board and Howick

**Next Meeting – May 18, 2026 at 8pm**

**Motion to change meeting date to May 25<sup>th</sup>, 8pm and that treasurer is able to pay any bills the week prior if interest will be charged. Jamie, Ian.**

**Adjournment of Meeting: 8:48pm**

**Motion to adjourn by: Warren**

***Previous Action Items***

Lead	Agenda Item/Topic	Actions for Follow Up
Jeremy/ Warren /Kim	<b>General Maintenance</b>	<p><b>20241118:</b> Glass broken along top of timekeepers' box.</p> <p><b>20251117:</b> Outside lights at the main hall – water pools within the light fixtures. Will need to have a look and find replacement fixtures.</p> <p><b>20251117:</b> Constant drip in ladies bathroom (hall side), first sink.</p> <p>20260316: Things to be added to repair list</p> <ul style="list-style-type: none"> <li>• Tap in the kitchen to be fixed.</li> <li>• Water Bottle fill in dressing room is not running cold. They are running warm.</li> <li>• Motion tap not working in dressing room 1.</li> <li>• Post broken – glass and post in the refs room. Will add to list for summer work.</li> <li>• Centre chandelier is broken. There is an extra we can replace with once rentals slow down.</li> </ul>
Board	<b>Structural Condition Assessment</b>	<p>20260216: Board will review report and create a To-Do List.</p> <p>20260420: Plan to work away at items within the structural assessment through the summer.</p>
Kim/Jenn	<b>2027 Rental Rate Increase</b>	20260316: Jenn reached out to Howick Twp to see if they are updating their fees bylaw before the fall. No response back.
Jeremy	<b>Board Chair</b>	20260420: Jeremy will speak to Randy and ask if he is willing to step into the Chair position.
Ian/Board	<b>Modification of Boards Opening at Curling Club End</b>	20260420: Ian to order materials and work to start on next rainy day.
Parks Comm.	<b>Topsoil &amp; Grass Cutting</b>	<p>20260420: Brett requested to purchase load of topsoil – approved.</p> <p>20260420: Will ask Jackson if he is willing to cut grass again this summer.</p>
<b>Parking Lot</b>		
Jeremy / Brett	<b>Parks Board</b>	<p><b>20240715:</b> Willow tree in back corner needs to be taken down before it crashes down. Should do this before winter.</p> <p>20251117: suggestion to contact an arborist for work to be done in 2026.</p>
Jeremy/ Warren	<b>General Maintenance – for Summer</b>	<p>20230228:</p> <ol style="list-style-type: none"> <li>1) Brine header – preventative maintenance by 2025. <ul style="list-style-type: none"> <li>○ <b>20230821:</b> Need to let Municipali.es know (in November/December) about Brine Header replacement project before their budgets are made.</li> <li>○ <b>20231016:</b> working on a couple of quotes for brine headers.</li> <li>○ <b>20240617:</b> spoke with Ben and his company should have time to repair it. Moving ahead with this.</li> <li>○ <b>2024118:</b> Q1-Q2 should hear whether or not we received grant money</li> </ul> </li> </ol>

		<ul style="list-style-type: none"><li>▪ If we don't receive grant, we need to put it into a budget</li><li>○ 20250520: Jeremy will confirm with Ben if he can repair. Chamber will need to know by early June.</li></ul> <p>20250915: BRINE HEADER will be going ahead now and will be completed within a month.</p> <ul style="list-style-type: none"><li>- Will need new boards over the Curling Header. Kyra will look for Gord's drawings from a few years ago. Then Kim will ask Gord to look at it.</li></ul> <p>20251020: briner header is going in "as we speak"</p> <ul style="list-style-type: none"><li>2) Boards around the ice surface need to be replaced.</li></ul> <p><b>PUT INTO PARKING LOT</b></p>
--	--	-----------------------------------------------------------------------------------------------------------------------------------------------------------------------------------------------------------------------------------------------------------------------------------------------------------------------------------------------------------------------------------------------------------------------------------------------------------------------------------------------------------------------------------------------------------------------------------------------------------------------------------------------------------------------------------------------------------------------

<b>Adjournment:</b>	<b>Next Meeting - Monday, May 25, 2026 at 8pm</b> (moved from May 18 <sup>th</sup> to accommodate long weekend)
---------------------	-----------------------------------------------------------------------------------------------------------------



**Ministry of  
Municipal Affairs  
and Housing**

Office of the Minister

777 Bay Street, 17<sup>th</sup> Floor  
Toronto ON M7A 2J3  
Tel.: 416 585-7000

**Ministère des  
Affaires municipales  
et du Logement**

Bureau du ministre

777, rue Bay, 17<sup>e</sup> étage  
Toronto (Ontario) M7A 2J3  
Tél. : 416 585-7000



234-2026-1746

June 1, 2026

On May 25, 2026, our government introduced the proposed [Protecting Ontario's Streets and Communities Act, 2026](#) (Bill 119). Through this legislation, we are proposing new tools to address zoning by-law contraventions which respond to recommendations and requests from municipal leaders. The proposed *Planning Act* changes, if passed, would enable municipalities to use an administrative monetary penalty (AMP) system for zoning by-law contraventions which relate to land uses that are not permitted.

We are interested in receiving your comments on these proposed changes. Comments can be made through the Environmental Registry of Ontario Posting [026-0558](#) Proposed Planning Act Changes (Schedule 7 of Bill 119 - *Protecting Ontario's Streets and Communities Act, 2026*) from May 26, 2026, to June 25, 2026. The government invites you to review the [Environmental Registry of Ontario and Regulatory Registry of Ontario](#) links provided above and share any feedback you may have.

If you have any questions, please reach out to my Director of Stakeholder Relations, Caucus Affairs and Public Appointments, Tanner Zelenko at [tanner.zelenko@ontario.ca](mailto:tanner.zelenko@ontario.ca).

I look forward to continued collaboration with you to address these and other important issues facing our communities.

Sincerely,

A handwritten signature in blue ink that reads "Robert J. Flack".

Hon. Robert J. Flack

Minister of Municipal Affairs and Housing

c. The Honourable Graydon Smith, Associate Minister of Municipal Affairs and Housing

Robert Dodd, Chief of Staff Minister's Office

Matthew Rae, Parliamentary Assistant, Municipal Affairs and Housing

Laura Smith, Parliamentary Assistant, Municipal Affairs and Housing

Brian Saunderson, Parliamentary Assistant, Municipal Affairs and Housing

Martha Greenberg, Deputy Minister, Municipal Affairs and Housing

David McLean, Assistant Deputy Minister, Municipal Affairs and Housing

Laurie Miller, Assistant Deputy Minister, Municipal Affairs and Housing

Sean Fraser, Assistant Deputy Minister, Municipal Affairs and Housing

Municipal Chief Administrative Officers

**MEMORANDUM TO:** Heads of Council - Ontario Municipalities

**DATE:** May 22, 2026

**FROM:** Tom McKinlay,  
Assistant Deputy Attorney General

**RE:** **Follow-up to Updates to “Tailgate Event” Permits** under  
the *Liquor Licence and Control Act, 2019*

---

Further to my earlier letter dated January 13, 2026, I am writing to provide clarification regarding bring-your-own event permits.

### **What is the change?**

Recent amendments to Ontario Regulation 747/21 (Permits) under the *Liquor Licence and Control Act, 2019* (LLCA) introduce a new bring-your-own event permit. This change expands what was previously called the tailgating permit.

This permit allows individuals aged 19 and older to bring and consume their own liquor within a designated area of a cultural or community event that has been approved by a municipality **or** held in connection with, and in proximity to, a professional, semi-professional or post-secondary sporting event.

### **What action should municipalities take?**

Municipalities have the option to designate community or cultural events as eligible for the new bring-your-own event permit. **Importantly, municipalities are not required to designate any events as eligible.**

Event organizers who are interested in the bring-your-own permit will need to approach the municipality where they would like to hold the event and seek designation as a community or cultural event. The government recognizes that municipalities are best positioned to understand local needs and contexts, and therefore to determine whether and how to designate eligible events.

Municipalities may establish their own local processes to determine which events qualify and the form of the municipal designation.

There would be two routes a municipality could take:

- Review each request on a case-by-case basis before their council or;
- Delegate the authority to designate events to a municipal official, such as the clerk

Municipalities that do not wish to allow bring-your-own events may choose to express their position by way of a resolution.

These amendments do not affect existing municipal approval requirements for events held on municipal property (e.g., parks).

### **What about events tied to sporting events?**

Unlike the cultural or community permitting process, bring-your-own events that are held in proximity to a professional, semi-professional or post-secondary sporting event are unchanged and do not require a designation by the responsible municipality.

### **What action do organizers take once a municipality designates their event as community or cultural?**

It is up to event organizers to confirm with the responsible municipality that their event qualifies as a designated cultural or community event.

Once confirmed, organizers may apply for a bring-your-own event permit through the [iAGCO portal](#). **The AGCO will issue a permit only where the applicant provides proof of municipal designation.**

### **Why did the Government make this change?**

This change is intended to provide greater flexibility for some event organizers, potentially reducing costs and increasing attendance. For example, a movie screening in a municipal park may invite more of a “picnic atmosphere” and thus, organizers may prefer the bring-your-own permit.

The province recognizes that this permit may not be relevant to all. Events that rely on alcohol sales and do not use a bring-your-own model may continue to operate as usual.

### **What considerations were made for safety?**

All permitted events will continue to be subject to the existing health and safety requirements under the LLCA. Permit-holders are responsible for ensuring these standards and requirements.

### **What if I still have questions?**

If you have any questions about these regulatory changes, please contact Armina Samadi, Director, Agency and Tribunal Relations Branch at [Armina.Samadi@ontario.ca](mailto:Armina.Samadi@ontario.ca).

If you have any questions about AGCO permits and the application process, please contact Ruxandra Ilicea, Senior Eligibility Officer at [Ruxandra.Ilicea@agco.ca](mailto:Ruxandra.Ilicea@agco.ca).

Yours truly,



Tom McKinlay  
Assistant Deputy Attorney General

c: Armina Samadi  
Director, Agency and Tribunal Relations Branch, Ministry of the Attorney General

Leslie Fenton  
Director, Corporate Affairs, Governance and Agency Oversight, AGCO

## Good News

### A Celebration of Student Senators and Members of the Indigenous Student Grand Council

A reception was hosted in order to acknowledge and celebrate the students who participate in two groups that provide valuable input and voice to the trustees and senior staff. A recap of their accomplishments from the 2025/2026 school year was provided and each member received a certificate and gift to thank them for their contributions. The board thanks them for their participation and valuable insight!



### AMDSB and OSSTF Celebrate Excellence in Public Education

Chair Michael Bannerman was pleased to share that he, along with Vice Chair Patricia Smith and members of the senior team, attended the OSSTF event celebrating "Excellence in Public Education" on May 7. In a celebration of student achievement and teaching excellence, award recipients include secondary students, secondary teachers, support staff members, community members, and two especially-excellent elementary students. A full list of the award winners can be viewed on the [Excellence in Public Education page](#).

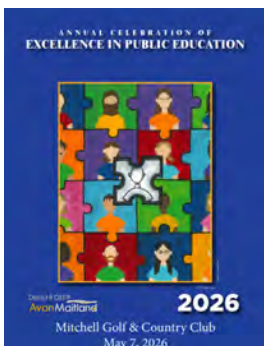

### Anne Hathaway PS Creates New Buddy Bench to Support Students

Chair Michael Bannerman was pleased to share that Anne Hathaway PS recently installed a new "Buddy Bench" to encourage conversation, friendship and early self-advocacy among students. The project was led by the school's School (Parent) Council and supported by Mark's Stratford through their community involvement initiatives, as well as Stratford Metal Products who created the sign for the bench. Full details can be found in a [recent Stratford Today article](#) by local reporter Alex Hunt. Photo credit: Alex Hunt



## Students Showcase Art Pieces at the Blyth Festival Art Gallery

Trustee Nancy Rothwell proudly shared that students across Huron and Perth county schools showcased their art pieces at the Blyth Festival Art Gallery.

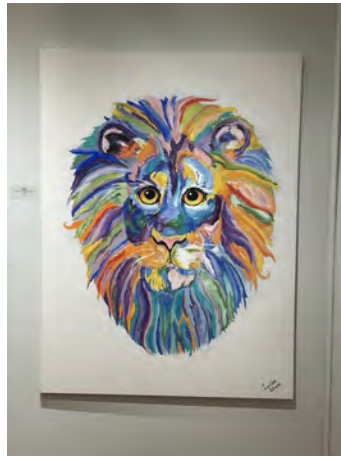

## North Perth Hosts 2nd Annual Cultural Unity Festival

Student Trustee Jaelynn MacPherson highlighted the recent event hosted among North Perth schools on May 6. This event was hosted last year and she was pleased to report that the attendance increased and participants enjoyed engaging in a number of activities including clothing displays, food sampling, painting and cultural dance performances. Using a passport, participants were able to show which countries they visited. A well attended event!

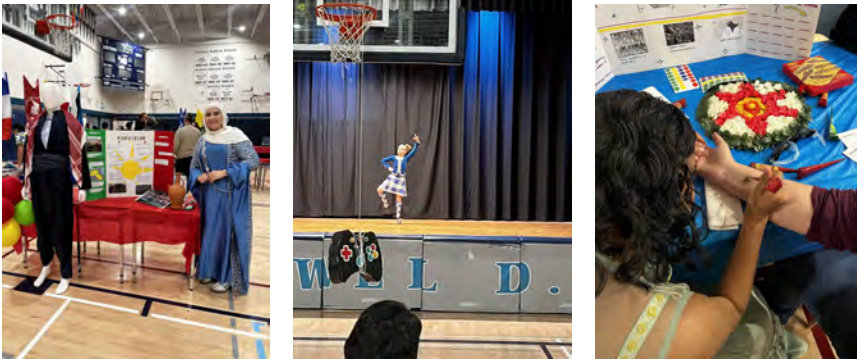

## AMDSB Students Showcase Talent at Skills Ontario Competition

Superintendent Paul Langis highlighted the recent success of AMDSB elementary and secondary students at the recent Skills Ontario Competition. Just over 50 elementary students and 10 secondary students participated in a variety of events including character animation, construction, LEGO robotics, carpentry, electrical, job interview and more! Three AMDSB groups/competitors won bronze medals in: Character Animation (Stratford Intermediate School Grade 7/8), Construction (South Huron DHS Grade 7/8), and Job Interview (Central Huron SS Secondary). Way to go!



## Improving Math Outcomes Across AMDSB

Superintendent Riley Culhane highlighted that educators across our district continue to utilize High Impact Instructional Practices daily in their classrooms. This year, the focus is specifically on Effective Learning Tasks, Deliberate Practice and Small Group Instruction. The images below show students at Romeo PS, Howick Central PS, Anne Hathaway PS and Mornington Central PS engaged in their learning through the use of these practices in their classrooms.



## Students Host Anti-Hate Conference

Superintendent Culhane was also pleased to share that on May 5, Stratford District SS hosted the Anti-Hate Conference 2.0 in partnership with Listowel District SS. Each secondary school across the district sent up to 10 students and a teacher sponsor to this student-led event, where students selected speakers and shaped the content. The Indigenous Student Grand Council participated as part of their individual school teams, but also as its own community. Topics focused on inclusive communication, leadership, school inclusivity planning, unpacking student voice on equity issues, and understanding bias, culminating in honest, transformative conversations about belonging, loss, and love. Student and staff feedback from the day was very positive, and we would like to thank everyone who contributed to making this a fantastic day of learning for everyone.



## AMDSB Schools Continue to Support Cancer Research through the Terry Fox Foundation

Communications Manager Chera Longston expressed pride for the support shown by students, staff, and families through their fundraising efforts during the Terry Fox Run last fall. Schools across AMDSB raised over \$82,000 for the Terry Fox Foundation, with Upper Thames ES leading the way with an impressive

contribution of \$12,442.55. Since AMDSB began hosting these fundraising events schools have raised over 1.5 million dollars - great work, AMDSB!



## School Showcase

Communications Manager Chera Longston highlighted **Howick Central PS**, located near Gorrie (Vice Chair Patricia Smith), and serves approximately 320 elementary students (grades K to 8). Its progression school is FE Madill SS. The building opened in 1963 and is led by Principal Paul Menary and Vice Principal Michael Bennie under the supervision of Superintendent Jane Morris.

### Highlights from Howick include:

- Team work: Staff and students together to create spaces for student leadership and voice, extra curricular teams and activities, clubs and band.
- Community Connection: Howick is very connected to its surrounding communities. The local Legion, Optimist, parent council and Josslin Insurance have all made generations donations to help support their library, nutrition programs, extracurricular activities, school wide events and community closet. Howick students also give back, connecting with a local retirement home, hosting sock drives, Jump rope for heart, Terry Fox runs and food drives.
- Student events: Remembrance Day ceremony, Carnaval, and an amazing space for outdoor learning all contribute to the positive learning environment at Howick.

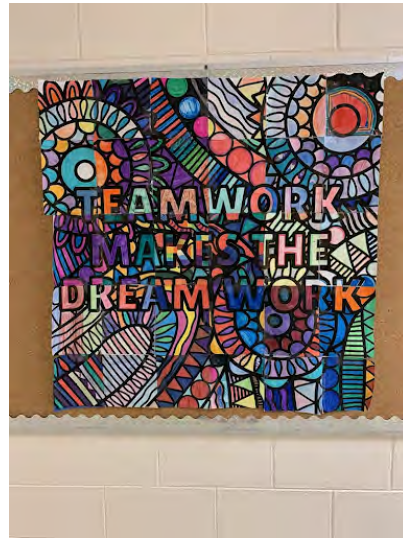

## Days of Significance Wrap-Up (May)

Schools celebrated important days throughout the month of May. The video below provides a sampling of these activities!

[May DOS Wrap Up Video](#) by AMDSB Communications

## Trustees Move Forward with Another Phase of the Strategic Plan (2026-2030)

Trustees approved a first draft of the 2026-2030 Strategic Plan. Details will be released in the coming months including graphics and details of the plan. Stay tuned!

## Student Trustee Update

Student Trustee Julia Havenga shared that the Student Senate hosted their election for the 2026/2027 school year. Congratulations to Mollie Hannam (Stratford District SS) who will serve as President and Arina Postovalova (South Huron DHS) who will serve as Vice President. She explained that their next meeting will welcome incoming senators for introductory activities and provide them with a handbook to help guide them in their role.

## Future Board Meetings

Regular Board Meetings are held in person unless otherwise noted. Links to join the Regular Board meetings online will be posted on the [Board Meeting page](#) the day before the meeting.

- Tuesday, June 9, 2026 at 4:45 p.m. (Regular Session, followed by Committee of the Whole, Closed Session)

- Tuesday, June 23, 2026 at 4:15 p.m. (Regular Session, followed by Committee of the Whole, Closed Session - via MS Teams)

## Future Meetings/Events with Trustee Representation

- Parent Involvement Committee (PIC) – Wednesday, May 27, 2026 at 6:30 p.m. (MS Teams)
- Special Education Advisory Committee (SEAC) – Wednesday, June 3, 2026 at 4:00p.m. (MS Teams)
- Audit Committee – Wednesday, June 3, 2026 at 5:00 p.m.
- Equity Steering Committee – Thursday, June 4, 2026 at 12:30 p.m.
- Finance Committee – Tuesday, June 16, 2026 at 4:00 p.m. (MS Teams)
- AODA – Wednesday, June 17, 2026 at 3:00 p.m. (MS Teams)
- Finance Committee – Tuesday, June 23, 2026 at 12:00 - 12:45 p.m. (MS Teams)



President: *Shawn O'Rourke*

Office Administrator: *Lori Gordon*

42 First Ave, Clinton, ON N0M 1L0 519-482-9642/1-800-511-1135 ph  
519-482-1416 fax [office@hcfa.on.ca](mailto:office@hcfa.on.ca) [www.hcfa.on.ca](http://www.hcfa.on.ca)

**Lisa Thompson, MPP Huron Bruce:**

408 Queen St.

PO Box 426

Blyth, ON N0M 1H0

**Email:**[lisa.thompsonco@pc.ola.org](mailto:lisa.thompsonco@pc.ola.org)

May 3, 2026

Dear Lisa,

Huron County is the most agriculturally productive county in Ontario, and we strive to ensure that sustainable, vibrant, and profitable farms continue to thrive in our region. The Huron County Federation of Agriculture (HCFA) proudly represents over 2,000 farm families across the county.

The HCFA would like to draw your attention to concerns raised by the Western Ontario Wardens' Caucus (WOWC) regarding proposed changes under Bill 100, the *Better Regional Governance Act, 2026*. The WOWC is urging the provincial government to maintain the current local governance structure at the municipal level and has expressed serious concern that Bill 100 represents a shift away from locally accountable municipal governments.

The WOWC emphasizes that counties and regions are not structured in the same way as large urban cities. Regions such as Huron County operate under a two-tier municipal system built on collaboration between upper- and lower-tier municipalities. Bill 100 does not adequately recognize the structural and functional differences between rural and urban municipalities.

Of particular concern is the provision in Bill 100 that would grant appointed chairs enhanced executive powers similar to strong mayor provisions. The WOWC is concerned that these powers could potentially override local decision-making and weaken accountability at the municipal level.

The WOWC is therefore advocating that the Province ensure any future reforms:

- Maintain locally elected leadership
- Recognize differences between municipal structures
- Reflect rural and regional realities

- Be developed in partnership with municipalities

Strong local governance is essential to agriculture, as municipal decisions directly affect planning decisions, farmland preservation, infrastructure investment, and rural economic development. Any shift away from locally elected responsibility risks the awareness of municipal government to the needs of farm families and rural communities.

The HCFA shares these concerns and supports a governance model that preserves local accountability and respects the unique needs of rural communities such as Huron County.

We request that the WOWC concerns be fully considered in any amendments to Bill 100 before it proceeds further. Thank you for your attention to this important matter.

Sincerely,

Shawn O'Rourke, President Huron County Federation of Agriculture

c.c. County of Huron and Lower Tier Municipalities

Ministry of the Environment, Conservation and Parks

# Improving Ontario's Conservation Authority System

Technical Briefing for Municipalities

June 2, 2026

# Purpose and Outline

## Purpose:

- To provide an overview of Ontario's plan to improve the conservation authority (CA) system.

## Outline:

- Overview and context
- Amendments to the *Conservation Authorities Act* to enable transition activities and consolidation of CAs
- Transition milestones and timelines
- Next steps

# Overview and Context



# Context: Improving Ontario's CA system

Ontario is taking action to build on the legislative and regulatory amendments made since 2019 to ensure CAs have the tools required to protect the communities they serve, supporting economic prosperity while balancing conservation and development needs.

The government is making improvements to Ontario's conservation authority system in multiple phases:

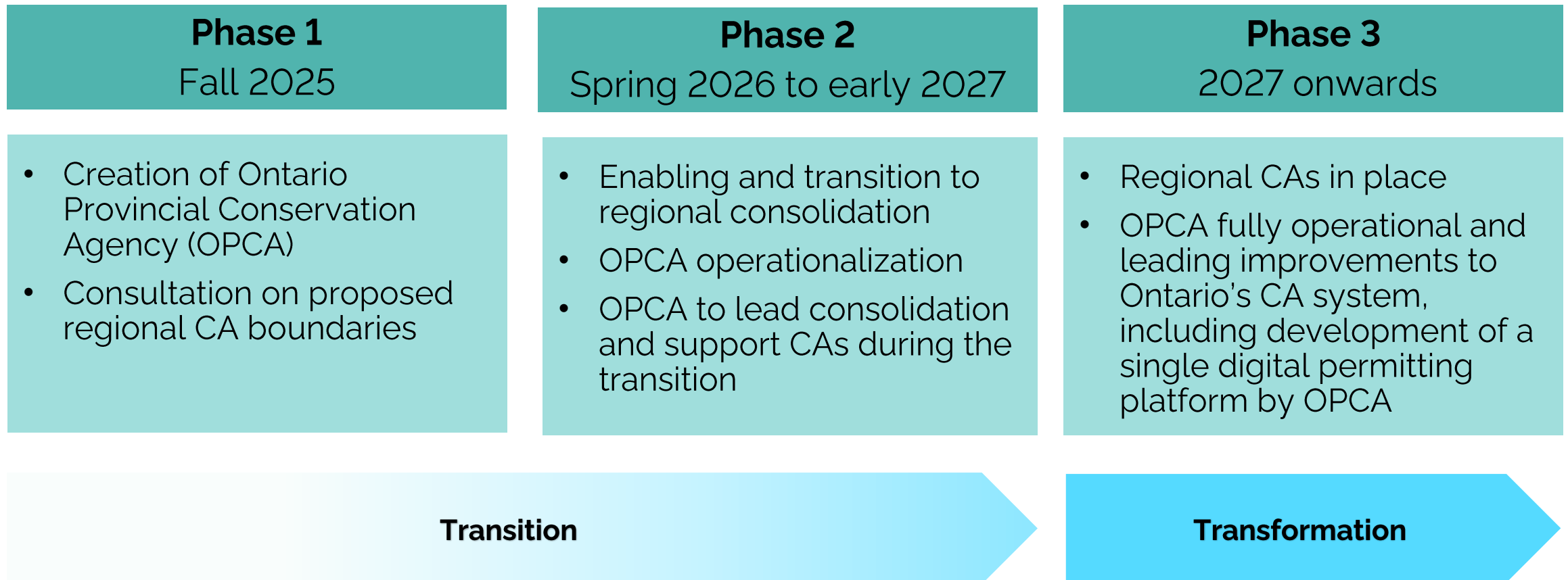

# Guiding principles

- The following principles informed the actions the province is taking to improve CAs, in addition to feedback heard during consultation:
  - **Retain local influence** – ensure local knowledge, expertise and interests inform the watershed management and conservation work of CAs
  - **Maintain CA watershed-based jurisdictions** – align with natural hydrological boundaries to support flood/water management. Align with drinking water source protection regions
  - **Reduce administrative overlap and duplication** – streamline requirements and processes for municipalities and conservation authorities
  - **Strengthen CA capacity** – improve and standardize the level of expertise and resources across CAs. Seek to balance the needs and interests of urban, rural, northern and southern watersheds
  - **Continuity of services** – minimize disruptions to CA operations and staffing, ensuring uninterrupted delivery of key programs such as permits, watershed management and trails and recreation for public use
  - **Improve customer service** – enhance consistency and clarity in process and timelines

# Regional Consolidation

## What these changes mean:

- More resources for front-line services
- Improved flood management and erosion prevention
- Strong environmental protections maintained
- Faster permit approvals
- Modern service delivery
- Consistent standards and use of modern technology

## What's not changing:

- Where CAs operate (areas currently served by CAs will continue to be served by CAs)
- The programs and services CAs provide, including the responsibility for source water protection, natural hazard and watershed management
- CA ownership and management of their lands and trails, providing access to green spaces, recreation and education programs
- Where and how CAs receive funding
- CA relationships with municipalities, developers, landowners
- Each regional CA being an independent, municipally-governed organization

**Amendments to the  
*Conservation  
Authorities Act***



# Amendments to the *Conservation Authorities Act*

- Bill 97 was passed on April 23, 2026, and given royal assent on April 24, 2026.
- Schedule 3 of Bill 97 proposed amendments to the *Conservation Authorities Act* (CAA) to set out the provisions for provincially-led consolidation to create 9 regional CAs, including:
  - Statutory amalgamation
  - Transition committees, project executives and transition plans
  - Prohibitions during the transition period
  - Governance of regional CAs
  - Other amendments
- Many of the transition provisions in the legislation are time-limited and will be repealed at a later date by commencement order.

# Boundaries of the 9 regional CAs

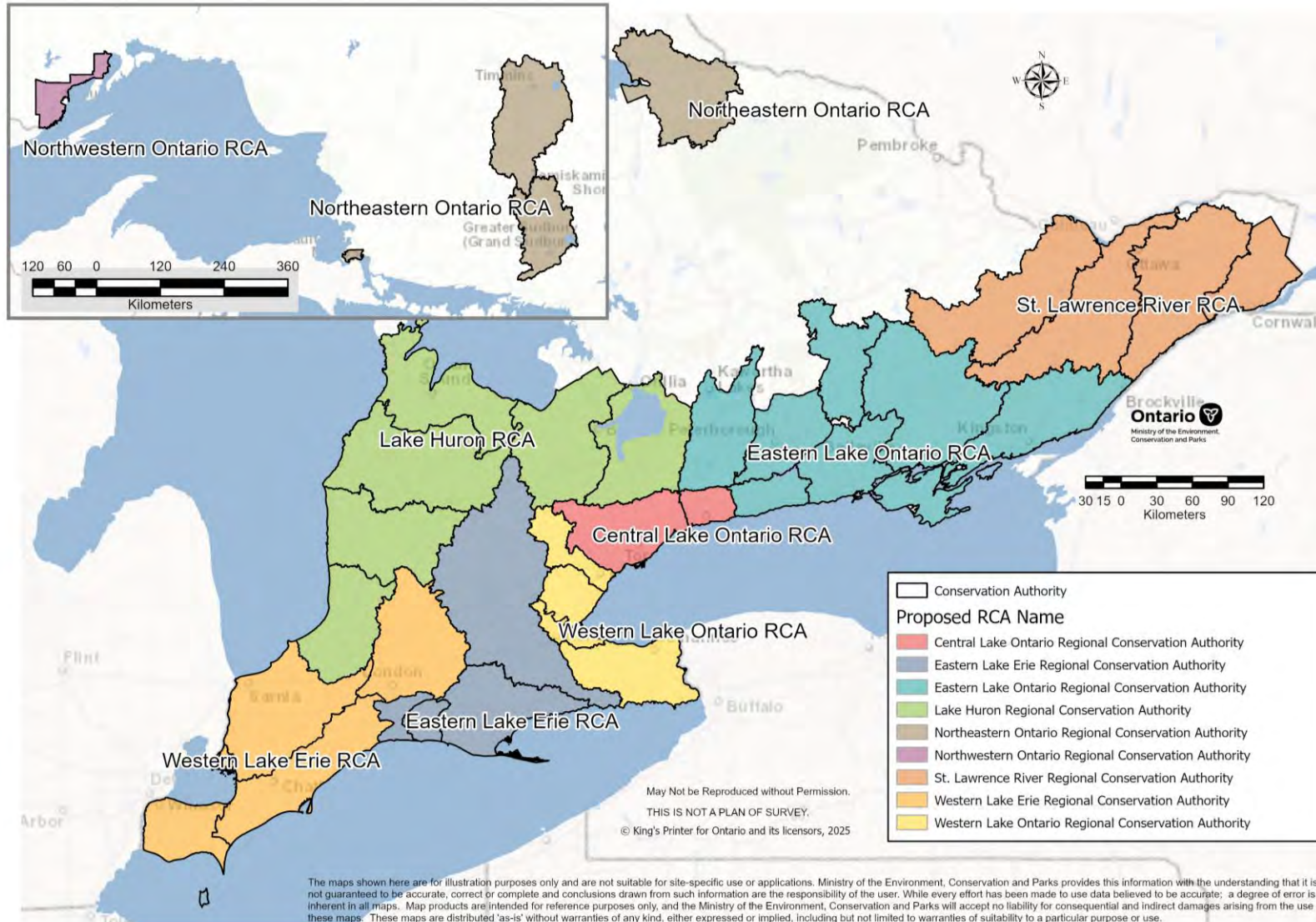

\*Transition to regional CAs is to take place on February 1, 2027 (or a later date that may be prescribed by regulation).

Map for illustrative purposes

# Statutory Amalgamation

- On the transition date, the “predecessor authorities” (i.e., the existing CAs) will be amalgamated and legally continue as the “new authority” (i.e., regional CA) set out in the Table included in section 1.3 of the legislation (see Appendix 1).
- Lakehead Region Conservation Authority will continue as the Northwestern Ontario Regional Conservation Authority.
- The transition date is defined as February 1, 2027 (or a later date prescribed by regulation).

Existing 36 Conservation Authorities

**Statutory amalgamation**  
→  
**Early 2027 (February 1)**

9 regional Conservation Authorities

## Part I.1: Transition to new authorities

1.2	Definitions
1.3	Amalgamation of predecessor authorities
1.4	Continuation of Lakehead Region CA as Northwestern Ontario Regional CA

### What these changes mean:

The new regional CAs will replace the former CAs as legal entities to avoid disruptions to existing partnerships and agreements with municipalities, Indigenous communities, or others and CA operations.

# Rules for Amalgamation

The legislation sets out rules for the amalgamation that apply on and after the transition date. For example:

- All rights, obligations, assets and liabilities of the predecessor CAs become those of the new authority.
- All partnerships, agreements or memoranda of understanding or debts due to the predecessor CAs become those of the new authority.
  - Including the continuance of agreements or MOUs to provide municipal programs and services (category 2\_ under section 21.1 of the CAA and funding agreements with lower-tier municipalities for other programs and services under section 21.1.2 of the CAA (category 3) which would be deemed to be an agreement with the upper-tier participating municipality.
- Employment of employees of the predecessor CAs is not terminated (all rights, duties and liabilities transfer).
- Current jurisdiction of the individual CAs are combined to become the jurisdiction of the consolidated regional CA.
- The participating municipalities of a new authority will be the single-tier and the upper-tier municipalities located in whole or in part within its area of jurisdiction.
- Permit applications are continued with the new authority. Any hearings underway or hearing requests continue with the new authority.
- Persons appointed as officers under 30.1 become officers appointed by the new authority.

- The amalgamation of the predecessor CAs into the new regional CAs will be governed by the *Public Sector Labour Relations Transition Act* (PSLRTA), which sets out a clear, structured and neutral framework for dealing with labour relations issues following restructuring of public sector organizations (e.g., the need to rationalize bargaining units).
- Key benefits of applying PSLRTA include:
  - Enhanced clarity in the process for negotiating changes to the number and composition of bargaining units, representation votes for employees on which bargaining agent will represent the bargaining unit (subject to voting thresholds), application of collective agreements as a “composite agreement”, and negotiation of a new collective agreement.
  - Seniority is “dovetailed” so that seniority rights are merged and sorted by employee starting date with the former employer.

# Project Executive

- The Agency to appoint a project executive to chair each transition committee.
- The project executive is not an employee of the Agency and will be paid compensation and expenses agreed to with the Agency.
- The Agency may issue directions to the project executive.
- The project executive is to become the inaugural Chief Administrative Officer (CAO) of the new authority for up to 24 months.
- During the 24 months, the Agency may provide written notice that the project executive is no longer the CAO and provide the name of a new individual. If an individual is not identified, the authority may appoint the CAO.
- The Agency may establish and require the payment of fees by the new CA respecting the appointment of a project executive in relation to their role as the first CAO.

## Part I.1: Transition to new authorities

1.6	Transition committees
1.12	First chief administrative officer

## Part VIII.1 The Agency

35.25	Fees to be paid to Agency
-------	---------------------------

### **What these changes mean:**

OPCA will appoint a Project Executive to lead the transition committee and ensure uninterrupted stewardship up to 24 months to support a smooth transition.

After the transition date, the Project Executive, serving as the CAO, would begin to take direction from the members of the regional CA on day-to-day matters.

# Transition Committees

OPCA to establish a Transition Committee for each regional CA to prepare for amalgamation. The committees would be dissolved after the transition date.

## Appointment of Members

- Each predecessor authority is to appoint two members to the transition committee:
  1. Municipally elected member of the CA
  2. CAO or general manager of the CA (or an alternative if they are not available)
- The predecessor authority may replace a member it has appointed.
- If the predecessor authority does not appoint the individuals within 90 days of Royal Assent (July 23, 2026), the Agency would appoint members on their behalf.
- The Agency may also appoint other individuals to be members of the committee.

## **What these changes mean:**

OPCA to coordinate consolidation by establishing a transition committee and providing resources, tools and guidance to support transition for each regional CA being consolidated.

# Transition Plans

- Agency to issue directions to the transition committee to:
  1. Govern the roles, responsibilities, practices and procedures of the transition committee and project executive; and
  2. Require preparation for amalgamation, including preparation of a transition plan.
- Project Executives could require predecessor CAs to provide information to support transition planning. transition plan, the Agency may provide comments and direct revisions to the transition plan or confirm that no revisions are necessary.
- The final transition plan and/or a summary is to be shared with the CAs, participating municipalities and Agency.
- The new conservation authority can request the Agency to authorize amendments to the transition plan.
- Each new conservation authority will be required to implement the final transition plan and report to the Agency on implementation progress.
- The Agency will prepare the transition
- Upon review of the plan if the committee does not submit the plan by a specified date.

Part I.1: Transition to new authorities	
1.7	Agency direction to transition committee
1.8	Project executive request for information
1.9	Co-operation of predecessor authority
1.10	Development of transition plan
1.11	Implementation of transition plan

## What these changes mean:

With direction from OPCA, transition committees to develop and implement transition plans to lead each new regional CA through a step-by-step integration of its predecessor CAs across key functions such as HR, finance, assets, and IT.

# Temporary Restrictions

- The Minister is enabled to issue temporary directions to prohibit certain decisions or require the CA to give notice of a decision and require authorization from a specified person (e.g., Agency or Transition Committee).
  - Minister Direction issued to CAs on May 1, 2027.
- All directions would expire on the earlier of the date in the direction or the transition date.
- A decision by the authority in contravention of a direction would have no legal effect and any resulting agreement is void.
- The provisions for the establishment, enlargement, municipally-led amalgamation, and dissolution of a conservation authority to be suspended.

## **2027 CA Budgets**

- Directions may also be issued to manage the 2027 budget process for the 36 predecessor CAs, which could be used to provide clarity around process and timelines.
  - e.g., direct that budgeting by predecessor CAs be completed by end of 2026/early 2027 and levies be issued to the current participating municipalities.
- Budget-related regulations will be reviewed to ensure they function in alignment with the new regional CAs and their participating municipalities.

### **Part I.1: Transition to new authorities**

1.13	Prohibitions during transition period (boundaries)
1.14	Prohibitions during transition period (Minister's directions)

### **What these changes mean:**

Temporary restrictions are applied to extraordinary decisions to mitigate risk and ensure a stable transition to the new regional structure. These measures are intended to not interfere with regular day to day CA business and operations.

# Regional CA Governance

- Councils of each participating municipality (i.e., upper- and single-tier) will appoint members to the authority for up to a four-year term. Members are eligible to be reappointed. Term limits for chairs and vice-chairs are up to two years.
- Legislation removes requirements that 70 per cent of appointments be elected officials and that the chair and vice chair be filled on a rotating basis between participating municipalities. Removal of rotation requirements are in effect upon Royal Assent (April 24, 2026).
- When appointing a person who is not a member of municipal council, the council is to consider:
  - (a) the person's knowledge and experience in public administration, corporate governance and finance
  - (b) the person's knowledge of programs and services provided by authorities
  - (c) other matters prescribed by Minister's regulation
- MECP Minister retains ability to appoint an agricultural representative.

## Part IV: Membership and Governance

14	Members of authority
17 (1) to (1.3)	Chair and vice-chair

**What these changes mean:**  
CAs continue to be municipally governed organizations, with members appointed by the upper-tier and single-tier municipalities.

# Regional CA Member Appointments

- Rules for how members are to be selected are to be set out in LGIC regulation, including:
  - Maximum number of members to be appointed by a single participating municipality and by all participating municipalities.
  - Method for determining the number of members based on the municipality's proportion of the population within the CA's jurisdiction – minimum of one member for each participating municipality.
- The participating municipalities could come to an agreement to use a different method provided that the maximum numbers set out in regulation are not exceeded. The agreement must be provided to the Agency and posted on the CA's website.
- Members must be a resident in a participating municipality of the new authority.

## **First members (i.e. “board”) of an authority**

- Participating municipalities of the new authorities are required to appoint members to the new authority before the transition date and notify the Agency.

### Part IV: Membership and Governance

14 Members of authority

### Part I.1: Transition to new authorities

1.5 First members of an authority

## **What these changes mean:**

Selection of members continues to be generally based on a “rep by pop” formula guaranteeing each participating municipality a member and limiting the number of members appointed by any one municipality to ensure fairness and balance.

Current boards continue to operate during the transition period and members of the new conservation authority will be appointed in advance to ensure continuity.

# Watershed Councils

- Regional CAs to be required to establish one or more watershed councils to assist the authority in identifying local priorities for its programs and services and ensure local interests are considered as part of the authority's decision-making process.
- Specific requirements for the composition, functions, powers, duties, activities and procedures of a watershed council may be set out in Minister's regulation.
  - For example, Indigenous representatives to enable considering Indigenous knowledge, or agriculture and development representation to consider other local watershed perspectives.

**What these changes mean:**  
Regional CAs continue to rely on the deep local expertise, knowledge and relationships CAs have built.

# Clean Water Act (CWA) / Source Protection

- Protecting drinking water sources remains a government priority.
- Ontario continues to fund over \$7M per year to source protection authorities and other recipients for source water protection.
- It is recognized that changes may be needed under the *CWA* and associated regulations to function in alignment with the changes to conservation authority names and boundaries and to clarify how source protection authorities would operate under the regional CA structure.
- Consequential changes needed to the *CWA* will be focused on ensuring stability, clarity, and continuity of the mandatory source water protection program as the *CAA* changes are implemented.

# Transition milestones and timelines



# Key Milestones

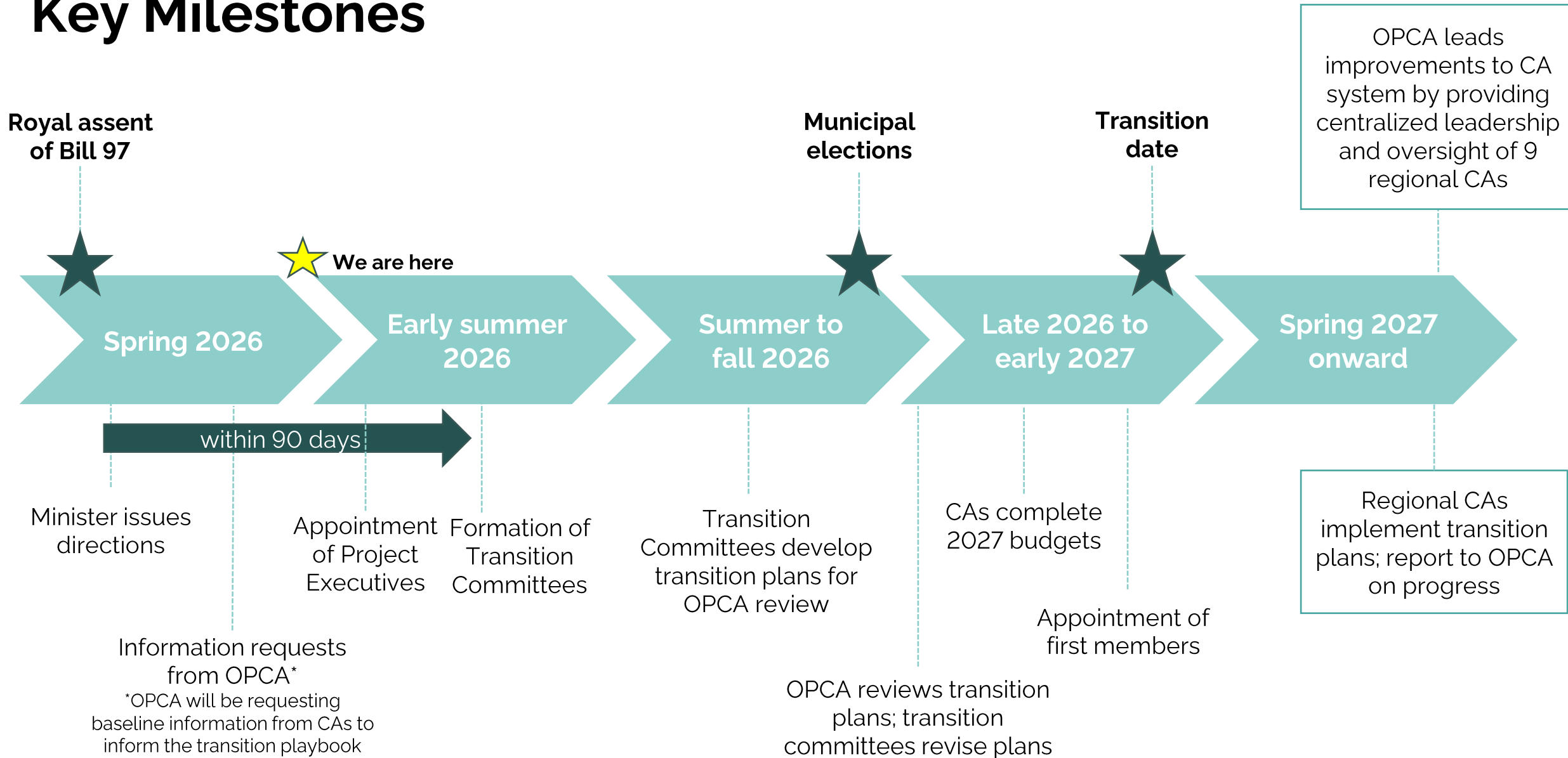

# Key Steps in Process

	Spring 2026	Summer 2026	Fall 2026	Winter 2027
MECP	<ul style="list-style-type: none"> <li>Royal assent of bill</li> <li>Minister issues directions for temporary guardrails</li> </ul>	<ul style="list-style-type: none"> <li>Minister issues direction on budgeting</li> </ul>	<ul style="list-style-type: none"> <li>Appointment of OPCA Board of Directors and CEO</li> </ul>	<ul style="list-style-type: none"> <li>Further legislative and regulatory changes</li> </ul>
OPCA	<ul style="list-style-type: none"> <li>Initial information requests sent to CAs to inform transition committee playbook</li> </ul>	<ul style="list-style-type: none"> <li>Appointment of project executives</li> <li>Establish transition committees</li> </ul>	<ul style="list-style-type: none"> <li>Review of transition plans</li> </ul>	<ul style="list-style-type: none"> <li>Dissolve transition committees</li> </ul>
Transition Committee		<ul style="list-style-type: none"> <li>Develop and submit transition plans</li> </ul>		<ul style="list-style-type: none"> <li>Finalize transition plans</li> </ul>
CA	<ul style="list-style-type: none"> <li>Provision of information per OPCA request</li> </ul>	<ul style="list-style-type: none"> <li>Transition committee members appointed within 90 days of Royal Assent</li> </ul>	<ul style="list-style-type: none"> <li>Provide information to transition committees (if requested)</li> </ul>	<ul style="list-style-type: none"> <li>Completion of 2027 budgets</li> <li>Levies issued</li> <li><b>Transition date to regional CA</b></li> </ul>
Municipality			<ul style="list-style-type: none"> <li>Municipal elections; board members serve until a replacement is appointed</li> </ul>	<ul style="list-style-type: none"> <li>First members appointed prior to transition date</li> </ul>

# Immediate Next Steps

- Following recent appointments of OPCA Board of Directors (April 16) and CEO (May 15), continued operationalization for OPCA stand-up by the ministry and the Office of the Chief Conservation Executive (OCCE).
- OCCE to continue engaging with CAs on transition and consolidation. OCCE/OPCA to appoint and then onboard Project Executives to chair Transition Committees.
- CAs make appointments to Transition Committees by June 30.
  - Each predecessor CA to appoint: (1) the chief administrative officer or general manager of the CA and (2) a member of the CA who is a member of municipal council.
  - OPCA to appoint additional Transition Committee members (if any).
- Minister to issue direction for 2027 CA Budgets, and MECP to provide municipal levy apportionment data.
- OPCA to issue a direction containing the Consolidation Playbook with standard expectations for Transition Plans, roles and deliverables.
- Transition Committees to develop Transition Plans in accordance with any OPCA directions.

# Additional Questions?

- The Office of the Chief Conservation Executive is leading CA transition activities as OPCA becomes fully operational. For questions regarding the plans for consolidation, please contact [CCEO@ontario.ca](mailto:CCEO@ontario.ca).
- For questions about the legislative amendments and day-to-day CA business, please reach out to MECP staff via [ca.office@ontario.ca](mailto:ca.office@ontario.ca).

# Appendices

1. List and map of regional CAs
2. CAA amendments



# Appendix 1: Names of Regional CAs

Proposed Regional CAs ("new authority")	List of existing CAs being consolidated ("predecessor authority")	
<b>Central Lake Ontario Regional Conservation Authority</b>	<ul style="list-style-type: none"> <li>Central Lake Ontario CA</li> </ul>	<ul style="list-style-type: none"> <li>Toronto and Region CA</li> </ul>
<b>Eastern Lake Erie Regional Conservation Authority</b>	<ul style="list-style-type: none"> <li>Catfish Creek CA</li> <li>Grand River CA</li> </ul>	<ul style="list-style-type: none"> <li>Kettle Creek CA</li> <li>Long Point Region CA</li> </ul>
<b>Eastern Lake Ontario Regional Conservation Authority</b>	<ul style="list-style-type: none"> <li>Cataraqui Region CA</li> <li>Crowe Valley CA</li> <li>Ganaraska Region CA</li> <li>Kawartha Region CA</li> </ul>	<ul style="list-style-type: none"> <li>Lower Trent RegionCA</li> <li>Otonabee Region CA</li> <li>Quinte Region CA</li> </ul>
<b>Lake Huron Regional Conservation Authority</b>	<ul style="list-style-type: none"> <li>Ausable Bayfield CA</li> <li>Grey Sauble CA</li> <li>Lake Simcoe Region CA</li> </ul>	<ul style="list-style-type: none"> <li>Maitland Valley CA</li> <li>Nottawasaga Valley CA</li> <li>Saugeen Valley CA</li> </ul>
<b>Northeastern Ontario Regional Conservation Authority</b>	<ul style="list-style-type: none"> <li>Mattagami Region CA</li> <li>Nickel District CA</li> </ul>	<ul style="list-style-type: none"> <li>North Bay Mattawa CA</li> <li>Sault Ste. Marie Region CA</li> </ul>
<b>Northwestern Ontario Regional Conservation Authority</b>	<ul style="list-style-type: none"> <li>Lakehead Region CA</li> </ul>	
<b>St. Lawrence River Regional Conservation Authority</b>	<ul style="list-style-type: none"> <li>Mississippi Valley CA</li> <li>Raisin Region CA</li> </ul>	<ul style="list-style-type: none"> <li>Rideau Valley CA</li> <li>South Nation River CA</li> </ul>
<b>Western Lake Erie Regional Conservation Authority</b>	<ul style="list-style-type: none"> <li>Essex Region CA</li> <li>Lower Thames Valley CA</li> </ul>	<ul style="list-style-type: none"> <li>St. Clair Region CA</li> <li>Upper Thames River CA</li> </ul>
<b>Western Lake Ontario Regional Conservation Authority</b>	<ul style="list-style-type: none"> <li>Credit Valley CA</li> <li>Halton Region CA</li> </ul>	<ul style="list-style-type: none"> <li>Hamilton Region CA</li> <li>Niagara Peninsula CA</li> </ul>

# Appendix 1: Ontario's current 36 CAs

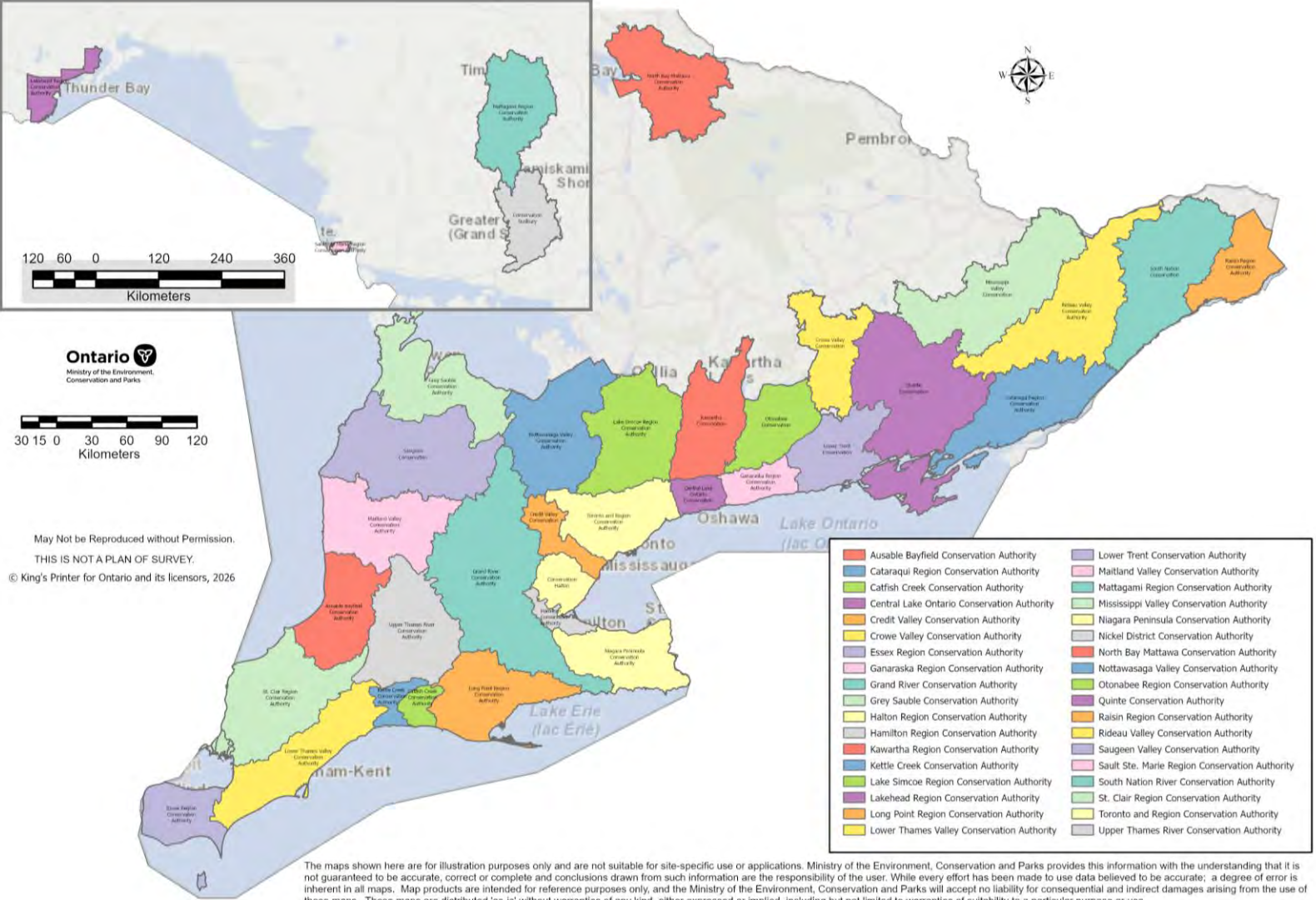

The maps shown here are for illustration purposes only and are not suitable for site-specific use or applications. Ministry of the Environment, Conservation and Parks provides this information with the understanding that it is not guaranteed to be accurate, correct or complete and conclusions drawn from such information are the responsibility of the user. While every effort has been made to use data believed to be accurate, a degree of error is inherent in all maps. Map products are intended for reference purposes only, and the Ministry of the Environment, Conservation and Parks will accept no liability for consequential and indirect damages arising from the use of these maps. These maps are distributed 'as-is' without warranties of any kind, either expressed or implied, including but not limited to warranties of suitability to a particular purpose or use.

# Appendix 2: Other CAA Amendments

- Updates to the by-laws section to clarify that an authority is required to make by-laws necessary for its proper administration and adding chief administrative officer, in addition to the secretary-treasurer, as a person/position for whom a by-law may prescribe powers and duties.
- Defining a municipality as a lower-tier, upper-tier or single-tier municipality for the purposes of s. 21.1.1 (municipal programs and services).
- Updating references to the Lake Simcoe Region Conservation Authority to the Lake Huron Regional Conservation Authority.
- Updating the provisions for directions by the Minister to the Agency to add that the Agency will comply within a specified time and that Part II of the Environmental Bill of Rights does not apply.
- Updating the provisions for directions by the Agency to authorities to add that authorities will comply within a specified time and that Part II of the Environmental Bill of Rights does not apply to the Minister's consideration of a proposed direction or a decision by the Minister.
- Adding that the project executive would be protected from liability.
- Repealing sections relating to regional municipalities as participating municipalities, continuation of certain CAs, references to transition plans re: s. 21.1.2 (2), and extension of time for determining apportionment of capital costs and for determining apportionment of operating expenses.

Other sections being amended	
18	Chief administrative officer
19.1	By-laws
21.1 (2)	Lake Simcoe Region Conservation Authority
21.1.1	Definition of municipality
35.1.6	Direction by Minister
35.21	Agency directions to authorities
39.1 (1)	No personal liability

Other sections being repealed	
3 (3)	Name of authority
4	Regional municipalities to act in place of local municipalities
5 to 7	Toronto and Region CA, Hamilton Region CA, Grand River CA
21.1.4	Transition plans re 21.1.2 (2)
25 (1.3)	Extension of time re recovery of project capital costs
27 (1.3)	Extension of time re recovery of operating expenses

# Appendix 2: New Regulation Making Powers

Part IX: Miscellaneous	
40 (1)	LGIC regulation making powers
40 (3)	Minister regulation making powers

## LGIC

- Prescribing a date for the definition of “transition date” (i.e., if after February 1, 2027)
- Appointing members
  - Prescribing the method for determining the number of members to be appointed to an authority
  - Prescribing the maximum number of members to be appointed to an authority by a single municipality
  - Prescribing the maximum number of members to be appointed by all participating municipalities
  - Prescribing the other criteria that must be satisfied when participating municipalities enter agreements on other methods for determining the number of members they will appoint to the authority

## Minister

- Prescribing additional rules for amalgamation
- Prescribing other matters for the considerations for appointing members that are not members of council
- Governing watershed councils, including the number of watershed councils (minimum, maximum or fixed number), and prescribing requirements for the composition, functions, powers, duties, activities and procedures of any watershed council

## Membership Meeting #4-2026

April 15, 2026

**Members Present:** Ed McGugan, Alvin McLellan, Megan Gibson, Matt Duncan, Anita Van Hittersum, Evan Hickey, Ed Podniewicz, Vanessa McMillan, Alison Lobb, Sharen Zinn

**Members Absent:** Andrew Fournier

**Staff Present:** Phil Beard, General Manager-Secretary-Treasurer  
Jayne Thompson, Communications Coordinator  
Stewart Lockie, Conservation Areas Services Coordinator  
Donna Clarkson, Source Water Protection Specialist  
Jeff Winzenried, Flood Forecasting Supervisor  
Michelle Quipp, Executive Assistant

**Others Present:** Cory Bilyea, Midwestern News Media  
Janet Stavinga, Watershed Conservation Coalition

### 1. Call to Order

Chair Ed McGugan, welcome everyone and called the meeting to order at 7:00pm.

### 2. Declaration of Pecuniary Interest

There were no pecuniary interests at this time.

### 3. Minutes

#### **Motion FA #41-26**

**Moved by:** Alvin McLellan

**Seconded by:** Alison Lobb

THAT the minutes from the General Membership Meeting #3-2026 held on March 18, 2026, be approved.  
(carried)

#### 4. Presentations

- a) Janet Stavinga, Watershed Conservation Coalition

Janet Stavinga shared key issues identified by the Watershed Conservation Coalition related to the proposed consolidation of Ontario's conservation authorities.

- b) Jeff Winzenreid, Flood Forecasting Supervisor: March Flood Event

Jeff Winzenreid made a presentation about a flood event that effected the Lucknow.

#### 5. Business Out of the Minutes

- a) Draft Response to Consolidation of Conservation Authorities: Report #21-2026

Report #21-2026 was presented and the following motion was made:

**Motion FA #42-26**

**Moved by:** Megan Gibson

**Seconded by:** Evan Hickey

THAT Report #21-2026 be accepted, as presented, with the additions identified by the members relating to need to consider future generations and concerns with representation by population.  
(carried)

#### 6. Business Requiring Direction and/or Decision:

- a) Proposed Legislative Changes: Conservation Authorities Act: Report #22-2026

Report #22-2026 was presented and the following motion was made:

**Motion FA #43-26**

**Moved by:** Alison Lobb

**Seconded by:** Evan Hickey

THAT Report #22-2026 be accepted.  
(carried)

- b) Government Relations Strategy for 2026: Report #23-2026

Report #23-2026 was presented and the following motion was made:

**Motion FA #44-26**

**Moved by:** Alison Lobb

**Seconded by:** Anita van Hittersum

THAT staff prepare a newsletter outlining 2026 activities and a separate newsletter regarding the amalgamation of conservation authorities, following the release of the regulations, for distribution to member municipalities and counties.  
(carried)

c) Information/Education Topics for 2026: Report #24-2026

Report #24-2026 was presented and the following motion was made:

**Motion FA #45-26**

**Moved by:** Matt Duncan

**Seconded by:** Megan Gibson

THAT the education topics recommended within Report #24-2026 be approved.  
(carried)

d) Planning for Last Members Meeting in October: Report #25-2026

Report #25-2026 was presented and the following motion was made:

**Motion FA #46-26**

**Moved by:** Evan Hickey

**Seconded by:** Alvin McLellan

THAT a daytime social with members, past members and staff will begin at 4pm on October 21, 2026 at Wroxeter Hall;  
AND THAT following a short break, members will reconvene to MVCA Administration Centre at 7pm.  
(carried)

e) Review of Proposals: Outdoor Pavilion-Wawanosh Valley: Report #26-2026

Report #26-2026 was presented and the following motion was made:

**Motion FA #47-26**

**Moved by:** Anita van Hittersum

**Seconded by:** Matt Duncan

THAT the Members award RFP MC#26-01-CA to Domm Construction Ltd. for the price of \$155,606.00 plus HST.  
(carried)

**7. Consent Agenda**

The following items were circulated to the Members for their information:

- a) Revenue/Expenditure Report for March: Report #27-2026
- b) Correspondence: Letter from Grey Sauble Conservation Authority

**Motion FA #48-26**

**Moved by:** Megan Gibson

**Seconded by:** Alison Lobb

THAT Report #27-2026 along with the respective motions as outlined in those reports be approved.  
(carried)

## 8. Chair and Member Reports

The Chair and Members did not have any reports .

## 9. Closed Session: Property Matter

### Motion FA #49-26

**Moved by:** Anita van Hittersum                      **Seconded by:** Alvin McLellan  
THAT the meeting be moved into a closed session at 8:58pm.  
(carried)

### Motion FA #50-26

**Moved by:** Anita van Hittersum                      **Seconded by:** Alison Lobb  
THAT the meeting be moved into an open session at 9:32pm.  
(carried)

## 10. Adjournment

Next Meeting Date, Wednesday, May 20, 2026, at 7:00pm at the Administration Centre in Wroxeter.

### Motion FA 51#-26

**Moved by:** Alison Lobb                                      **Seconded by:** Megan Gibson  
THAT the Members Meeting be adjourned at 9:32 pm.  
(carried)



---

Ed McGugan  
Chair



---

Phil Beard  
General Manager / Secretary-Treasurer



## Newsletter for Municipalities

May 2026

### Contents:

1. Annual Progress Report on source protection plan implementation
2. Source protection committee met in May
3. Source water protection education by municipalities
4. Drinking water source protection facts

### 1. Annual Progress Report for 2025 year

The Ausable Bayfield Maitland Valley Source Protection Committee (SPC) approved the 2025 **Annual Progress Report**. This is the ninth annual report submitted to the Province of Ontario, by the region, since 2017. The report documents achievements made with ministries, municipalities, and agencies to implement policies in the locally developed source protection plans. The report is on the local source protection website (<https://www.sourcewaterinfo.on.ca/documents/>).

The Province of Ontario approved our source protection plans in 2015, more than 10 years ago. Implementation of plan policies is progressing well and on target. All policies are implemented or in progress.

Eighty-five per cent of significant threats to drinking water have been addressed, according to the report. This is an increase from 80 per cent in the previous year. No issues have been identified, in terms of the quality of the sources of municipal drinking water, according to the progress report.

The year 2025 commemorated 25 years of drinking water protection improvements in Ontario. Water contamination in Walkerton, in 2000, resulted in the deaths of seven people. 2,300 people became ill. Measures to increase protection, since 2000, are documented in the Conservation Ontario video [25 Years of Source Water Protection in Ontario](#).

### 2. Source protection committee met in May

Source Protection Committee member Joy Rutherford, environmental sector representative and a retired hydrogeology geoscientist from Wingham, presented to the SPC's May 25 meeting in Clinton. Her presentation was called *Rocks & Water – Hydrogeology 101*. She gave the committee the basics of hydrogeology, which is foundational science for the drinking water source protection program. She provided information on the geology of our source protection region and demonstrated how water moves through aquifers.

## About Us

### Source Protection Committee

- 12 members plus a Chair
- Represents local municipalities; economic sectors; and Other/Public

### Source Protection Plans (SPP)

- Developed locally
- Approved by Province in 2015
- Updates approved in 2024
- Policies to protect municipal sources of drinking water
- Area covered – Ausable Bayfield and Maitland Valley source protection areas

### Goal:

To protect region's municipal sources of drinking water – aquifers and lakes – from contamination and overuse

### 3. Source water protection education by municipalities

We thank the municipalities in our region, implementing bodies for source protection education policy 0.11.7, for their work to educate their ratepayers about how to protect municipal sources of drinking water. To support education by municipalities, our region has been creating **#SourceWaterProtectionEducation** materials for use on social media. Thanks for sharing.

Our latest post, in May 2026, is about best practices to protect municipal sources of drinking water from the potential threat posed by pesticide application:

Applying pesticides properly helps to protect groundwater and surface water (e.g., Lake Huron) and it means less waste (and reduced costs) and more effective application.

Use the 4Rs of right product; at the right rate; at the right time; and at the right place.

Always read the pesticide label for information.

Check out the Ontario Crop Protection Hub to find out more about choosing which pesticide to use and about Integrated Pest Management (IPM). Using IPM may result in less need for use of pesticides to control crop pests: <https://cropprotectionhub.omafra.gov.on.ca/>

When pesticides are sprayed, it is important to prevent spray drift. Check out this presentation by Dr. Jason Deveau (<https://gfo.ca/webinars/graintalk-webinar-managing-drift-with-dr-jason-deveau/>) and this Province of Ontario web page: <https://www.ontario.ca/page/pesticide-drift-ground-applications>

### 4. Drinking water source protection facts

In our source protection region, there are more than 200 septic systems close to municipal wells. Those septic systems are inspected every five years. The goal of this reinspection program is to confirm they are functioning correctly and not contaminating sources of drinking water.

More than 80 drinking water protection zone signs have been installed in our source protection region. These signs tell the public they are in a vulnerable area, such as a (groundwater) wellhead protection area or (surface water) intake protection zone. The signs alert citizens that their actions in these zones can have an impact on municipal drinking water sources. Several municipalities in our region have included information about the signs, and the source protection program, on their websites.



Throughout Ontario, by the end of 2024, there were:

- 18,000 septic systems inspected since 2017.
- 2,000 risk management plans in place.
- 125 risk management officials ensuring compliance.
- 2,200 drinking water protection zone signs installed on Ontario roadways.

In Ontario, by the end of 2024, at least 94 per cent of those municipalities required to incorporate source protection into their Official Plans had done so.

---

Ausable Bayfield Maitland Valley Source Protection Region  
c/o Ausable Bayfield Conservation Authority  
71108 Morrison Line, R.R. 3  
Exeter, ON • N0M 1S5

Telephone: 519-235-2610  
Toll-free: 1-888-286-2610  
<https://www.sourcewaterinfo.on.ca/>

*This project has received funding support from the Government of Ontario.  
Such support does not indicate endorsement of the contents of this material.*

## Huron OPP Detachment Board

### Minutes

**Monday, March 23, 2026, 9:00 a.m.**  
**Huron OPP Detachment Office**  
**325 Albert Street, Clinton, ON, N0M 1L0**

Members Present: Marg Anderson, Vice Chair - Elected Official - Central Huron  
Anita van Hittersum, Member - Elected Official - North Huron  
Greg Lamport, Member - Elected Official - Bluewater  
Jim Dietrich, Chair - Elected Official - South Huron  
Trevor Bazinet, Member - Elected Official - Goderich  
Dave Frayne, Member - Provincial Appointee  
Jasmine Clark, Member - Community Representative  
Jennette Walker, Member - Community Representative  
Jared Petteplace, Member - Provincial Appointee

Member Regrets: John Steffler, Member - Elected Official - Huron East

Staff Present: Stacey Jeffery, Administrator/Recording Secretary

Others Present: Inspector Laura Lee Brown, Huron O.P.P.  
Hank Zehr, Police Service Advisor, SOLGEN

1. Call to Order

Chair Dietrich called the meeting to order at 9:03 a.m.

2. Approval of Agenda

**Motion:** 13-2026

**Moved:** DFrayne

**Seconded:** MAnderson

**That Huron OPP Detachment Board approves the Agenda as presented.**

**Disposition: Carried**

3. Disclosure of Pecuniary Interests and the General Nature thereof

4. Approval of Past Minutes

**Motion:** 14-2026

**Moved:** AvanHittersum

**Seconded:** GLampont

**That Huron OPP Detachment Board adopts the minutes of January 26, 2026 as printed and circulated.**

**Disposition: Carried**

5. Presentations/Delegations

5.1 Board Education: Provincial Constable Scott Mead, West Region Impaired Specialist

PC Scott Mead left the meeting at 9:57 a.m.

**Motion:** 15-2026

**Moved:** TBazinet

**Seconded:** JPetteplace

**That Huron OPP Detachment Board receives the educational session, as presented by Provincial Constable Scott Mead, West Region Impaired Specialist.**

**Disposition: Carried**

6. Business from Previous Meetings

7. Report

7.1 Inspector's Report

Inspector Brown clarified that 2 Provincial Offenses Tickets (POA) in 2026 are not shown in the Youth Charges by Disposition Type chart on page 6.

Member Bazinet left the meeting at 10:28 a.m.

**Motion:** 16-2026

**Moved:** JWalker

**Seconded:** MAnderson

**That Huron OPP Detachment Board receives the Inspector's Report as presented.**

**Disposition: Carried**

7.2 Financial Report

**Motion:** 17-2026

**Moved:** JClark

**Seconded:** AvanHittersum

**That Huron OPP Detachment Board receives the Financial Report titled Board Financial Actuals - January 1 to February 28, 2026, as presented.**

**Disposition: Carried**

8. New Business

8.1 OAPSB 2026 Spring Conference & Annual General Meeting

The Administrator noted that the approved 2026 budget includes budget amount to support attendance at the conference for all members, should they be able to participate.

**Motion:** 18-2026

**Moved:** GLamport

**Seconded:** JClark

**That Huron OPP Detachment Board approves all ten members to attend the OAPSB 2026 Spring Conference, should they be able to participate.**

**Disposition: Carried**

8.2 OAPSB AGM Call for Resolutions

8.2.1 Vulnerable Sector Checks

It was noted that the OAPSB AGM deadline for resolution submission is May 1, 2026.

Although wait times for vulnerable sector checks have recently improved, the Board discussed the need for a resolution to ensure processing remains efficient and that the most effective available methods are used.

Given the deadline and next scheduled Board meeting, Member Lamport to confirm with OAPSB if they will allow for a resolution to be submitted on May 25, after the Huron OPP Detachment Board meeting. Once confirmation is received, Member Lamport to bring a resolution for the Board's consideration to the May 25 meeting.

**Motion:** 19-2026

**Moved:** JPetteplace

**Seconded:** JClark

**That Huron OPP Detachment Board authorize Member Lamport to proceed with preparing a resolution related to vulnerable sector check processing times and methods to be presented to the Board at the next meeting; and**

**That Member Lamport confirm with the OAPSB that the resolution can be received after the May 1, 2026 date.**

**Disposition: Carried**

9. Board Member Comments

Chair Dietrich noted that they will be attending the OPP West Region Awards Ceremony with Inspector Brown. The awards ceremony will honour members from the detachment for their bravery and lifesaving efforts.

Member Anderson noted that the Board may be hosting the Zone 5 meeting in June and that if it is confirmed to host, the location would be at the Libro Hall in Clinton to accommodate attendance numbers and break out rooms.

Hank Zehr provided the Board an update on the province wide inspection on police corruption (independent inspector retained), Inspectorate of Policing (IOP) inspection of response times, as well noted the Inspector General Decision and Findings Reports.

**Motion:** 20-2026

**Moved:** DFrayne

**Seconded:** JPetteplace

**That Huron OPP Detachment Board approve hosting the Zone 5 meeting in June 2026 at the Libro Hall in Clinton.**

**Disposition: Carried**

10. Correspondence

10.1 Inspector General Memo #9: Province-Wide Inspection on Police Integrity and Anti-Corruption Practices

10.2 OAPSB Zone 5 Approved Minutes - December 9, 2025

**Motion:** 21-2026

**Moved:** MAnderson

**Seconded:** GLamport

**That Huron OPP Detachment Board receives correspondence items, as included under Correspondence.**

**Disposition: Carried**

11. Closed Session

**Motion:** 22-2026

**Moved:** DFrayne

**Seconded:** JPetteplace

**That Huron OPP Detachment Board proceeds in Closed Session at 10:55 a.m. for the purpose of information explicitly supplied in confidence to the board by Canada, a province or territory or a Crown agency of any of them, a municipality or a First Nation, in accordance with Section 44(2) of the Community Safety and Policing Act, 2019; and**

**That the Detachment Commander, Administrator, and Police Service Advisor (SOLGEN) remain in attendance.**

**Disposition: Carried**

12. Report from Closed

The Board returned to open session at 11:14 a.m.

Chair Dietrich reported that the Board met in Closed Session as per Section 44(2) of the Community Safety and Policing Act, 2019, for the purpose of information explicitly supplied in confidence to the board by Canada, a province or territory or a Crown agency of any of them, a municipality or a First Nation.

As a result of the closed session today, the closed meeting minutes of January 26, 2026, were approved as amended, and there were no resolutions to be considered in open session.

13. Next Meeting

May 25, 2026

14. Adjournment

**Motion:** 23-2026

**Moved:** MAnderson

**Seconded:** GLamport

**That Huron OPP Detachment Board hereby adjourns at 11:30 a.m., to meet again on May 25, 2026 at 9:00 a.m. or at the Call of the Chair.**

**Disposition: Carried**

---

Jim Dietrich, Chair

---

Stacey Jeffery, Recording Secretary



The Corporation of the Municipality of Wawa

REGULAR COUNCIL MEETING

RESOLUTION

Tuesday, June 2, 2026

Resolution # RC26118	Meeting Order: 7
Moved by: <i>Cathy Cannon</i>	Seconded by: <i>[Signature]</i>

**WHEREAS** municipal fire services in Ontario operate under legislative authority established by the Province through statutes, regulations, codes, and prescribed standards governing training, equipment, certification, inspection, and operational requirements; and

**WHEREAS** municipalities are responsible for implementing and maintaining compliance with these provincially mandated requirements primarily through local property taxation; and;

**WHEREAS** current provincial fire service grant programs are available to both full-time and volunteer fire departments across Ontario and are distributed through competitive application processes that may not fully reflect the differing financial and administrative capacities of urban and rural municipalities, highlighting the need for a more balanced approach to funding that supports all fire services equitably; and

**WHEREAS** volunteer firefighters represent approximately 70–75% of firefighters in Ontario, protecting the majority of communities across the Province and, particularly in rural areas, are frequently the first emergency responders to arrive on scene ahead of other emergency services; and

**WHEREAS** other provincially regulated emergency services, including policing and paramedic services, receive stable and predictable provincial funding contributions or cost-sharing arrangements; and

**WHEREAS** the absence of a comparable and stable funding model for fire services creates a structural imbalance between provincial regulatory authority and municipal financial responsibility; and

**WHEREAS** reliance on competitive funding creates budget uncertainty, limits long-term financial planning, and may not reflect the actual operational needs of fire services, contributing to instability, reduced preparedness, and the reduction of services within a critical emergency response sector; and



The Corporation of the Municipality of Wawa

REGULAR COUNCIL MEETING

RESOLUTION

WHEREAS stable and predictable funding is essential to maintain emergency preparedness, firefighter safety, service sustainability, and equitable protection for residents regardless of municipal size or tax base;

NOW THEREFORE BE IT RESOLVED THAT the Council of the Municipality of Wawa supports the resolution passed by the Town of Plympton-Wyoming calling upon the Province of Ontario to transition the current practice of competitive provincial fire service grant programs into a permanent, stable, and predictable non-competitive provincial funding program that supports municipalities in meeting provincially legislated fire protection requirements; and

BE IT FURTHER RESOLVED THAT this funding be structured to provide equitable and predictable annual support for operational readiness and training costs associated with volunteer, composite, and full-time fire departments across Ontario; and

BE IT FURTHER RESOLVED THAT the annual value of this funding be reviewed and adjusted to more appropriately reflect the level of provincial funding support currently provided to other provincially regulated emergency services, including policing and paramedic services; and

BE IT FURTHER RESOLVED THAT a copy of this resolution be circulated to:

The Association of Municipalities of Ontario, Rural Ontario Municipal Association, Ontario Association of Fire Chiefs, Ontario Professional Fire Fighters Association, Ontario Volunteer Fire Fighters Association, Bill Rosenberg MPP Algoma Manitoulin, The Honourable Michael Kerzner, Minister of the Solicitor General, The Honourable Kinga Surma, Minister of Infrastructure, The Honourable Rob Flack, Minister of Municipal Affairs and Housing and The Honourable Doug Ford, Premier of Ontario.

RESOLUTION RESULT	RECORDED VOTE	YES	NO
<input checked="" type="checkbox"/> CARRIED	MAYOR AND COUNCIL		
<input type="checkbox"/> DEFEATED	Mitch Hatfield		
<input type="checkbox"/> TABLED	Cathy Cannon		
<input type="checkbox"/> RECORDED VOTE (SEE RIGHT)	Melanie Pilon		
<input type="checkbox"/> PECUNIARY INTEREST DECLARED	Jim Hoffmann		
<input type="checkbox"/> WITHDRAWN	Joseph Opato		

Disclosure of Pecuniary Interest and the general nature thereof.

Disclosed the pecuniary interest and general name thereof and abstained from the discussion, vote and influence.

Clerk: \_\_\_\_\_

MAYOR - MELANIE PILON	CLERK - MAURY O'NEILL



# Corporation of the Municipality of Calvin Council Resolution

**Date:** May 27, 2026

## **Request for Provincial Review of CVA-Based Apportionment for Shared Municipal and Provincially Mandated Services**

**Resolution Number:** 2026-173

**Moved By:** Mayor Gould

**Seconded By:** Councillor Manson

WHEREAS many provincially mandated services, shared municipal services, and board-imposed levies are apportioned among municipalities using Current Value Assessment (CVA) or weighted assessment formulas; and

WHEREAS CVA-based apportionment formulas are intended to reflect municipal assessment capacity, but often do not adequately account for population, service access, geographic isolation, infrastructure constraints, or the differing realities of small and rural municipalities; and

WHEREAS municipalities with significant industrial assessment, utility corridors, resource infrastructure, protected lands, seasonal properties, or large geographic areas may experience disproportionately high per-resident levy impacts despite limited local services and lower resident incomes; and

WHEREAS some municipalities contribute substantially toward regional services such as long-term care, policing, conservation authorities, social services, and other provincially mandated boards and agencies, while residents may have limited local access to those services due to geography, travel distance, or service availability; and

WHEREAS increasing levy pressures are creating significant financial strain for small and rural municipalities and their residents;

NOW THEREFOR BE IT RESOLVED THAT The Council of the Municipality of Calvin requests that the Province of Ontario, including the Minister of Municipal Affairs and Housing and the Minister of Finance, undertake a review of policies, legislation, and regulations governing the use of Current Value Assessment (CVA) and weighted assessment as the basis for apportioning provincially-mandated levies and shared municipal service costs;

AND THAT the Province consider developing fairer and more balanced apportionment models which may include:

- hybrid formulas incorporating both CVA and population;
- consideration of service access and service availability;
- household count or permanent population metrics;
- ability-to-pay considerations for small and rural municipalities;
- rurality and geographic isolation factors; and
- measures to limit disproportionate per-resident levy impacts on smaller municipalities; and

AND THAT the Province work with the Association of Municipalities of Ontario (AMO), Rural Ontario Municipal Association (ROMA), rural municipalities, municipal service boards, and regional service providers to develop best practices and model apportionment frameworks for shared municipal services and provincially mandated boards;

AND THAT this resolution with the mayor's report attached, be circulated to:

- the Premier of Ontario;
- the Minister of Municipal Affairs and Housing;
- the Minister of Finance;
- The Minister of Rural Affairs
- the Association of Municipalities of Ontario (AMO);
- the Rural Ontario Municipal Association
- local Member of Provincial Parliament;
- all Ontario municipalities;
- and relevant municipal service boards and associations for consideration and support.

**Result: Carried**

CERTIFIED to be a true copy of  
Resolution No. 2026-173 passed by the Council of  
The Corporation of the Municipality of Calvin  
on the 26<sup>th</sup> day of May, 2026.



Trish Araujo  
Deputy Clerk



Report to Council by: Mayor Richard Gould Date: May 26, 2026

Subject: Request for Provincial Review of, and Change to CVA-Based Apportionment

The purpose of this report is to provide background information and supporting rationale for the attached resolution requesting that the Province of Ontario review the use of Current Value Assessment (CVA) and weighted assessment formulas as the basis for apportioning costs for provincially-mandated services, regional boards, and shared municipal services.

The report focuses on the growing financial impacts that CVA-based apportionment can have on small and rural municipalities, particularly where assessment values do not accurately reflect resident income levels, service access, or local municipal capacity.

Many shared municipal services and provincially-mandated boards in Ontario allocate costs among participating municipalities using Current Value Assessment (CVA) or weighted assessment formulas.

Examples include: Long-Term Care facilities; District Social Services Administration Boards (DSSAB); policing costs; conservation authorities; health and social service boards; and School boards and other regional service arrangements.

Under these formulas, municipalities with higher assessment values contribute a larger percentage of overall costs.

The intent of the current CVA-based apportionment is only a reflection of the municipalities "ability to pay." However, in many rural municipalities, assessment values do not accurately represent:

- or the actual level of services available within the municipality
- resident income levels;
- local economic strength;
- access to services;
- population density;
- transportation challenges.

As a result, some rural municipalities experience disproportionately high levy impacts on a per-household or per-resident basis.

Rural and Northern Municipal Realities

Small rural municipalities often differ significantly from urban centres in both geography and service availability.

In many cases:

- residents must travel substantial distances to access healthcare and government services;
- municipalities may lack public transit;
- municipalities may not have local hospitals, long-term care homes, or other major services;
- populations may be older and more geographically dispersed;
- infrastructure costs may be high due to large geographic areas and low population density.

At the same time, rural municipalities may contain:

- pipelines;
- hydro corridors;
- industrial infrastructure;

- protected lands;
- provincial parks;
- seasonal properties;
- or large acreages.

These features can substantially increase municipal assessment values while providing little indication of the financial capacity of local residents. This creates a disconnect between the assessed property value; and actual household ability to absorb increasing levy costs.

The Municipality of Calvin is a small rural municipality with approximately 230 households.

A significant portion of municipal assessment is influenced by industrial infrastructure, including a major pipeline corridor. The municipality also contains multiple provincial parks and large acreages, much of which limits future residential or commercial development opportunities.

Many residents live on inherited rural properties and have fixed or modest incomes. While assessment values may appear significant on paper, they do not necessarily reflect disposable household income or enhanced municipal service levels.

The Township has no hospital, no long-term care facility, no public transit, and limited local health and social service infrastructure.

Despite these limitations, the Township contributes toward many regional services through CVA-based apportionment formulas.

#### Cassellholme Capital Cost Example

The attached Appendix "A" illustrates the distribution of Cassellholme redevelopment capital costs among participating municipalities using:

- the current CVA formula;
- a household-based formula; and
- a hybrid formula combining CVA and household count.

The analysis demonstrates substantial differences in per-household impacts between municipalities.

Under the current CVA model:

- Calvin households contribute approximately \$393.89 per household;
- South Algonquin contributes approximately \$377.48 per household;
- Mattawan contributes approximately \$283.74 per household.

By comparison:

- Mattawa contributes approximately \$94.50 per household;
- Chisholm contributes approximately \$193.18 per household;
- North Bay contributes approximately \$203.56 per household.

Under a purely household-based model, the contribution would be approximately \$209.09 per household across all municipalities.

The analysis suggests that CVA-based formulas can create substantial disparities in per-household costs between municipalities, particularly in smaller rural communities where industrial or resource-based assessment inflates municipal valuation figures.

## Hybrid and Alternative Models

The report recommends that the province review whether the current reliance on CVA alone remains the most equitable method of apportionment in all circumstances.

Alternative approaches could include:

- hybrid formulas combining CVA and household count;
- formulas incorporating permanent population;
- service availability considerations;
- rurality and geographic isolation factors;
- ability-to-pay considerations;
- or mechanisms to limit disproportionate impacts on smaller municipalities.

The attached example demonstrates that even a partial hybrid approach can reduce extreme disparities while still recognizing assessment capacity.

## Broader Provincial Relevance

This issue extends beyond the Municipality of Calvin.

Many rural Ontario municipalities face similar circumstances where; industrial assessment; utility corridors, hydro infrastructure, pipelines, resource lands, or protected lands, increase municipal assessment values without proportionally increasing local service access or household financial capacity.

As provincial and regional levy pressures continue to rise, concerns regarding the fairness and sustainability of existing apportionment models are likely to become increasingly significant for rural municipalities across Ontario.

## Conclusion

The current use of CVA and weighted assessment formulas was developed to reflect municipal assessment capacity. However, the growing divergence between assessment values and the realities facing many rural municipalities suggests that a provincial review is warranted.

The Municipality of Calvin is requesting that the Province of Ontario review the use of CVA-based apportionment for provincially-mandated and shared municipal services and consider more balanced approaches that better reflect:

- household impacts;
- rural realities;
- service access;
- and municipal capacity.
- The attached resolution seeks to initiate that broader provincial discussion.
- Recommendation:

That Council adopt the attached resolution requesting a provincial review of Current Value Assessment (CVA)-based apportionment formulas for shared municipal and provincially-mandated services.

Appendix A:

Distribution of Capital cost for Cassellholme construction:

This chart shows the distribution of costs based on current CVA, Per Household, and a Hybrid of 75% per household and 25% CVA.

		Current CVA			Per Household				Hybrid 75/25	
Municipality	Households	Current CVA Pct	Current CVA Annual	Per household	Household based PCT	Household Based Annual	by household only	Hybrid PCT	Hybrid Annual	hybrid by household
North Bay	23470	79.187%	\$4,777,615.40	\$203.56	81.34%	4,907,375.69	209.09	80.8000%	4,874,935.62	207.71
East Ferris	1890	7.742%	\$467,100.64	\$247.14	6.55%	395,182.79	209.09	6.8480%	413,162.25	218.60
South Algonquin	530	3.316%	\$200,065.32	\$377.48	1.84%	110,818.45	209.09	2.2066%	133,130.17	251.19
Bonfield	890	3.237%	\$195,298.99	\$219.44	3.08%	186,091.37	209.09	3.1225%	188,393.27	211.68
Papineau-Cameron	405	1.726%	\$104,135.33	\$257.12	1.40%	84,682.03	209.09	1.4842%	89,545.35	221.10
Chisholm	510	1.633%	\$98,524.33	\$193.18	1.77%	106,636.63	209.09	1.7338%	104,608.55	205.11
Calvin	227	1.482%	\$89,414.00	\$393.89	0.79%	47,463.75	209.09	0.9605%	57,951.31	255.29
Mattawa	860	1.347%	\$81,269.00	\$94.50	2.98%	179,818.62	209.09	2.5721%	155,181.22	180.44
Mattawan	70	0.329%	\$19,861.73	\$283.74	0.24%	\$14,636.40	209.09	0.2642%	15,942.73	227.75
<b>TOTAL</b>	<b>28852</b>		<b>\$6,033,284.73</b>		<b>99.99%</b>	<b>\$6,032,705.73</b>	<b>209.09</b>	<b>1.00</b>	<b>6,032,850.48</b>	

Totals      65693                      \$6,033,284                      \$6,033,333                      \$6,033,333

Total Capital rebuild cost is and estimate of \$121,000,000 plus \$110,000,000 interest, minus the \$50,000,000 arranged by the province to be divided in each of the first years of the loan. This is a Total of \$181,000,000. Divided over the next 30 years this equals \$6,033,333 per year.



**Date:** 13 May 2026

**15**

**Moved By:** Deputy Mayor Netty McEwen

**Seconded By:** Councillor John van Klaveren

## **Support for Sustainable Provincial Grant Funding for Fire Services in Ontario**

**WHEREAS** Municipal fire services in Ontario operate under legislative authority established by the province through statutes, regulations, codes, and prescribed standards governing training, equipment, certification, inspection, and operational requirements;

**AND WHEREAS** municipalities are responsible for implementing and maintaining compliance with these provincially mandated requirements primarily through local property taxation;

**AND WHEREAS** current provincial fire service grant programs are available to both full-time and volunteer fire departments across Ontario and are distributed through competitive application processes that may not fully reflect the differing financial and administrative capacities of urban and rural municipalities, highlighting the need for a more balanced approach to funding that supports all fire services equitably;

**AND WHEREAS** volunteer firefighters represent approximately **70–75% of firefighters in Ontario**, protecting the majority of communities across the province and, particularly in rural areas, are frequently **the first emergency responders to arrive on scene ahead of other emergency services**;

**AND WHEREAS** other provincially regulated emergency services, including policing and paramedic services, receive stable and predictable provincial funding contributions or cost-sharing arrangements;

**AND WHEREAS** the absence of a comparable and stable funding model for fire services creates a structural imbalance between provincial regulatory authority and municipal financial responsibility;

**AND WHEREAS** reliance on competitive funding creates budget uncertainty, limits long-term financial planning, and may not reflect the actual operational needs of fire services, contributing to instability, reduced preparedness and the reduction of services within a critical emergency response sector;

**AND WHEREAS** stable and predictable funding is essential to maintain emergency preparedness, firefighter safety, service sustainability, and equitable protection for residents regardless of municipal size or tax base;

## NOW THEREFORE BE IT RESOLVED THAT

The Council of the Town of Plympton-Wyoming respectfully calls upon the Province of Ontario to **transition the current practice of competitive provincial fire service grant programs into a permanent, stable, and predictable non-competitive provincial funding program** that supports municipalities in meeting provincially legislated fire protection requirements;

**AND FURTHER THAT** this funding be structured to provide equitable and predictable annual support for **operational readiness and training costs associated with volunteer, composite and full-time fire departments across Ontario**;

**AND FURTHER THAT** the annual value of this funding be reviewed and adjusted to more appropriately reflect the level of provincial funding support currently provided to other provincially regulated emergency services, including policing and paramedic services;

---

**AND FURTHER THAT** this resolution be circulated for endorsement to:

- The County of Lambton
- Lambton County Fire Chiefs Association
- All municipalities
- Ontario Association of Fire Chiefs
- Ontario Professional Fire Fighters Association
- Ontario Volunteer Fire Fighters Association
- Association of Municipalities of Ontario
- Rural Ontario Municipal Association

---

**AND FURTHER THAT, upon endorsement, this resolution be submitted to:**

- Steve Pinnsoneault MPP Lambton-Kent-Middlesex
- Bob Bailey MPP Sarnia-Lambton
- The Honourable Michael Kerzner, Minister of the Solicitor General
- The Honourable Kinga Surma, Minister of Infrastructure
- The Honourable Rob Flack, Minister of Municipal Affairs and Housing
- The Honourable Doug Ford, Premier of Ontario

✓

Carried

Defeated

Deferred

**Ministry of Natural Resources**

Development and Hazard Policy  
Branch  
Policy Division  
300 Water Street  
Peterborough, ON K9J 3C7

**Ministère des Richesses naturelles**

Direction de la politique d'exploitation des  
ressources et des risques naturels.  
Division de l'élaboration des politiques  
300, rue Water  
Peterborough (Ontario) K9J 3C7

June 12, 2026

Good afternoon,

A critical step in protecting people and property from flooding starts with identifying where flooding is expected to occur. This is most often achieved through flood hazard mapping. Actions in *Protecting People and Property: Ontario's Flooding Strategy* commit the province to updating existing technical guidance used to support implementation of the natural hazard policies outlined within the *Provincial Planning Statement 2024*, and in conducting flood hazard mapping.

As part of its multi-staged approach to updating this technical guidance, today, the Ministry of Natural Resources released proposed updates to a technical guide and a new companion technical bulletin on the *Environmental Registry of Ontario* (ERO), posting 026-0329, to support municipalities and conservation authorities with flood hazard modelling and mapping activities. They include:

1. *Technical Guide - River and Stream Systems: Flooding Hazard Limit*; and
2. *Technical Bulletin - Special Flooding Hazard Conditions in River and Stream Systems*

The proposed technical guide provides updated guidance on recommended hydrologic and hydraulic methodologies to be used when conducting flood hazard analyses. The new proposed technical bulletin provides guidance on when and how flood mitigation structures are to be considered in flood hazard modelling and mapping. If the updates are accepted, this guidance is intended to be the definitive source of hydrologic and hydraulic methodologies for use in Ontario and would replace the primary chapters of the existing *Technical Guide - River and Stream Systems: Flooding Hazard Limit (2002)*.

To support the Environmental Registry posting, the ministry will be hosting two identical webinars on June 23, 2026 1:30 – 3:00 pm and June 25, 2026 1:30 – 3:00pm. To register to attend one of the webinars, please complete this [webinar registration form](#). Feedback on the draft technical guide and companion technical bulletin will be accepted until August 11, 2026 through the Environmental Registry.

Sincerely,

A handwritten signature in cursive script that reads "John Dungavell". The signature is written in black ink and is positioned above the printed name and title.

John Dungavell  
Director, Development and Hazard Policy Branch  
Ministry of Natural Resources

**By-law for Municipalities Not Within a Regional  
Municipality, the County of Oxford or The  
District Municipality of Muskoka – Form 5**

*Drainage Act, R.S.O. 1990, c. D.17, subs. 45(1)*

Drainage By-law Number 43-2026

A by-law to provide for a drainage works in the Township of Howick  
in the County of Huron.

Whereas the council of the Township of Howick has procured a  
report under section 78 of the *Drainage Act* for the improvement  
of the Merkley Municipal Drain drain;

And whereas the report dated 2026/05/15 has been authored by Spriet Associates Engineers & Architects  
and the attached report forms part of this by-law;

And whereas the estimated total cost of the drainage work is \$318,000.00 ;

And whereas \$310,231.00 is the amount to be contributed by the Township  
of Howick for the drainage works;

And whereas (Complete this clause only if other municipalities are being assessed a share of the cost of the project.);

\$7,769.00 is being assessed in the Municipality of Morris-Turnberry  
\_\_\_\_\_ is being assessed in the \_\_\_\_\_ of \_\_\_\_\_  
\_\_\_\_\_ is being assessed in the \_\_\_\_\_ of \_\_\_\_\_  
\_\_\_\_\_ is being assessed in the \_\_\_\_\_ of \_\_\_\_\_

And whereas the council is of the opinion that drainage of the area is desirable;

Therefore the council of the Township of Howick  
pursuant to the *Drainage Act* enacts as follows:

**1. AUTHORIZATION**

The attached report is adopted and the drainage works is authorized and shall be completed as specified in the report.

**2. BORROWING**

The Corporation of the Township of Howick  
may borrow on the credit of the Corporation the amount of \$318,000.00 being the amount necessary for  
the improvement of the drainage works.

This project will NOT be debentured.

**3. DEBENTURE(S)**

The Corporation may issue debenture(s) for the amount borrowed less the total amount of:

- (a) grants received under section 85 of the *Drainage Act*;
- (b) monies paid as allowances;
- (c) commuted payments made in respect of lands and roads assessed with the municipality;
- (d) money paid under subsection 61(3) of the *Drainage Act*; and
- (e) money assessed in and payable by another municipality.

**4. PAYMENT**

Such debenture(s) shall be made payable within \_\_\_\_\_ years from the date of the debenture(s) and shall bear interest at a rate not higher than 2% more than the municipal lending rates as posted by Infrastructure Ontario on the date of sale of such debenture(s).

- (1) A special equal annual rate sufficient to redeem the principal and interest on the debenture(s) shall be levied upon the lands and roads as shown in the schedule and shall be collected in the same manner and at the same as other taxes are collected in each year for \_\_\_\_\_ years after the passing of this by-law.
- (2) For paying the amount \_\_\_\_\_ being the amount assessed upon the lands and roads belonging to or controlled by the municipality a special rate sufficient to pay the amount assessed plus interest thereon shall be levied upon the whole rateable property in the Township of Howick in each year for \_\_\_\_\_ years after the passing of this by-law to be collected in the same manner and at the same time as other taxes collected.
- (3) All assessments of \_\_\_\_\_ or less are payable in the first year in which the assessments are imposed.

**5. SCHEDULE OF ASSESSMENTS OF LANDS AND ROADS**

in the Township of Howick

Property Description				Equal Annual Rate to be Imposed
Lot or Part Lot No.	Concession	Geographic Township	Parcel Roll No.	
<b>Total</b>				

6. CITATION

This by-law comes into force on the passing thereof and may be cited as the " Merkley Municipal Drain by-law".

First reading 2026/06/16

Second reading 2026/06/16

Provisionally adopted this 16 day of June, 20 26

Name of Head of Council (Last, First Name) <u>Harding, Doug</u>	Signature
--------------------------------------------------------------------	-----------

Name of Clerk (Last, First Name) <u>Gillis, Caitlin</u>	Signature
------------------------------------------------------------	-----------

Third reading 2026/08/11

Enacted this 11 day of August, 20 26

Name of Head of Council (Last, First Name) <u>Harding, Doug</u>	Signature
--------------------------------------------------------------------	-----------

Name of Clerk (Last, First Name) <u>Gillis, Caitlin</u>	Signature
------------------------------------------------------------	-----------

I, Caitlin Gillis  
clerk of the Corporation of the Township of Howick,  
certify that the above by-law was duly passed by the council of the Corporation and is a true copy thereof.

Name of Clerk (Last, First Name) <u>Gillis, Caitlin</u>	Signature
------------------------------------------------------------	-----------

**Corporation of the Township of Howick**

**By-law No. 44-2026**

---

**Being A By-Law To Authorize the Entering into and Execution of an Agreement between the Corporation of the Township of Howick and the Corporation of the Municipality of South Bruce for Hot Mix Paving as outlined in South Bruce Tender Documents PW-2026-03**

---

**WHEREAS** Subsection 5(1) of the *Municipal Act, S.O. 2001, c. 25* as amended, provides that the powers of a municipality shall be exercised by Council;

**AND WHEREAS** Subsection 5(3) of the *Municipal Act, 2001, S.O. 2001, c. 25*, as amended, provides that municipal power shall be exercised by By-law;

**AND WHEREAS** both parties have agreed to the Terms in the Contract attached as Schedule 'A' to this By-law;

**NOW THEREFORE IT BE ENACTED** by the Council of the Corporation of the Township Of Howick as follows:

1. That the Corporation of the Township of Howick enter into the Agreement (Schedule 'A') with The Corporation of the Municipality of South Bruce for Hot Mix Paving of Huron-Bruce Road and George Street, Gorrie, as outlined in South Bruce Tender PW-2026-03 (Schedule 'B').
2. That the Manager of Public Works is hereby authorized to execute and affix the Corporate Seal to an Agreement between the Corporation of the Township of Howick and the Corporation of the Municipality of South Bruce and any other relevant documents necessary for the execution of said Agreement.
3. That Schedules 'A' and 'B' form part of this by-law.
4. That this By-law shall come into force and take effect upon its final passage.
5. That this By-law may be cited as the "2026 Hot Mix Asphalt Paving" By-law.

**Read a first and second time this 16<sup>th</sup> day of June, 2026.**

**Read a third time and finally passed this 16<sup>th</sup> day of June, 2026.**

---

**Reeve Doug Harding**

---

**CAO/Clerk Caitlin Gillis**



**Agreement for Hot Mix Paving – Contract PW2026-3**

THIS AGREEMENT made in duplicate this 28 day of May, 2026

BETWEEN: **THE CORPORATION OF THE MUNICIPALITY OF SOUTH BRUCE**  
(hereinafter called the "Municipality")

AND

**TOWNSHIP OF HOWICK**  
(hereinafter called the "Township")

WITNESSETH:

In accordance with By-Law #2002-43 being a by-law to establish a Boundary Agreement between the neighbouring municipalities, being the Municipality of South Bruce and the Township of Howick, for the maintenance and repair of the shared boundary road (Huron-Bruce Road).

That any construction or capital work such as paving is agreed upon, and the costs for the work be shared equally between the two municipalities.

That the Municipality and the Township, in consideration of the fulfillment of their respective promises and obligations set forth in the tender PW2026-3, covenant and agree with each other as follows:

1. The Municipality of South Bruce shall act as an agent on behalf of the Township of Howick and to call for Tenders and to prepare and distribute the contract documents.
2. The Municipality of South Bruce and the Township of Howick are each Parties to this contract and shall individually have all the rights and privileges of the "Owner" as stipulated in the contract documents.
3. Enforcement of the Contract may be carried out collectively, or individually between any Parties, namely The Municipality of South Bruce, the Township of Howick and Lavis Contracting Co. Limited. (herein called the "Contractor").
4. Each of the Parties shall be severally liable for all provisions of the contract, including amounts owed to the Contractor. The Contractor shall not take action against any of the other Parties, for a breach of the Agreement committed by one Party.

5. The Contractor shall invoice the Municipality of South Bruce and the Township of Howick individually for the actual quantities used following the completion of their work. The Contractor is to submit an invoice indicating the amount and contract number to each individual Municipality for the work performed at each respective work location.
6. The Municipality of South Bruce shall be responsible for payment of the work on the boundary road, being the Huron-Bruce Road (Carrick/Howick) after the bridge at 911# 1568 to B-Line (Item A1 in the tender). The Municipality shall invoice the Township for 50% of this item, including shoulder gravel work.

**THE TOWNSHIP OF HOWICK**

I have the authority to bind the Corporation

  
\_\_\_\_\_  
SCOTT PRICE, MANAGER OF PUBLIC WORKS

**THE MUNICIPALITY OF SOUTH BRUCE**

I have the authority to bind the Corporation

  
\_\_\_\_\_  
STU MOFFAT, MANAGER OF OPERATIONS



A COLAS COMPANY

Cold In-Place Recycling – Asphalt Paving – Ready Mix Concrete Supply  
Excavating, Grading - Sand, Gravel - Sewer & Watermain

37462A Huron Rd., RR#2 Clinton, Ontario, N0M 1L0 – Phone: (519) 482-3694 – Fax: (519) 482-7886 – www.lavis.ca

Date: May 29, 2026  
To: Township of Howick

Attention: Scott Price  
Telephone:  
E-Mail: sprice@howick.ca  
Project: PW2026-3 - Hot Mix Paving

**Includes Addendums, #.**

We are pleased to submit a proposal to you as Contractor or Owner for furnishing the labour, materials and equipment required for the performance of the following described work (the "said work") at the above location and for the above owner.

Item	Description	Estimated Quantity	Unit	Unit Price	Amount
	<b>The Scope of Work is as follows:</b>				
	The following work was bid as a joint tender with the Municipality of South Bruce closing on Friday May 15, 2025. The work to be completed for the Township of Howick is as follows:				
B1	<b>George Street (Gorrie) - Victoria to Dead End</b> Cold Plane Existing Asphalt at Various Laneway Entrances 20-40mm Supply & Place 40mm HLL3 Surface Asphalt (7m Width)	80.00 320.00	m2 t	\$73.75 \$123.50	\$5,900.00 \$39,520.00 <b>\$45,420.00</b>
	<b>Notes:</b> - All work will be completed as per Contract No. PW2026-3 Specifications				

plus HST

It is understood that the foregoing is an estimate of the work and the materials and equipment required, and that payment shall be based on the stated unit prices for the actual work performed, and materials supplied and equipment used by the Company as determined upon completion of the work.

If the foregoing meets with your acceptance, kindly sign and return this proposal, which, upon receipt by us, becomes a binding contract. It is understood that the foregoing and the terms and conditions set forth on the accompanying page, will constitute the full and complete agreement between us.

**Accepted:**

By: Scott Price

Yours truly,

*Jeff Morley*

Date: June 3 2026  
Contractor or Owner

Jeff Morley, C.E.T.  
Lavis Contracting Co. Limited

Schedule 'B' to By-law 44-2026

**Agreement for Hot Mix Paving – Contract PW2026-3**

THIS AGREEMENT made in duplicate this \_\_\_\_\_ day of \_\_\_\_\_, 2026

BETWEEN: **THE CORPORATION OF THE MUNICIPALITY OF SOUTH BRUCE**  
(hereinafter called the "Municipality")

AND

**LAVIS CONTRACTING CO. LIMITED**  
(hereinafter called the "Contractor")

WITNESSETH:

That the Municipality and the Contractor, in consideration of the fulfillment of their respective promises and obligations set forth in the tender, covenant and agree with each other as follows:

The Contractor has carefully examined the provisions, plan, specifications and conditions, as noted in the Tender Document Contract PW2026-3 (hereinafter called the "Tender"), and has carefully examined the site and location of the work to be done under this contract, and the Contractor understands and accepts the said provisions, plans, specifications and conditions, and, for the prices set forth in the Tender, hereby offers to furnish all machinery, tools, apparatus and other means of construction, furnish all materials, except as otherwise specified in the Tender, and to complete the work in strict accordance with the provisions, plans, specifications, and conditions stipulated in the Tender.

Included with Tender is a Bid Bond in the amount specified in the Tender Requirements. The proceeds of this Bid Bond shall, upon acceptance of the Tender, constitute a deposit which shall be forfeited to the Municipality if the Contractor fails to file with the Municipality a Performance Bond, as required in the Tender, within fifteen (15) days from the date of Acceptance of the Tender.

The Contractor will file with each Municipality a completed performance bond, signed and sealed with a recognized bonding company, in the amount of 50% of the Total Tender Price. Upon receipt of such a bond, the tender deposit will be returned to the Contractor. The Performance Security shall remain in force and effect through the duration of the Contract and Warranty period. Through the whole warranty period (one year from the completion of the Project) the Municipality will maintain the securities in the amount equal to 50% of the total Contract value.

It is agreed that the Tender quantities are estimated only and may be increased or decreased by the Municipality without alteration of the contract price, however, such increase or decrease shall not exceed 20 percent.

I / WE (the Contractor) promise to commence work on \_\_\_\_\_ (to be completed by Contractor) and to diligently perform the work continuously without undue delay and further promise to complete the work by **September 1, 2026.**

The Municipality covenants with the Contractor that the Contractor having in all respects complied with the provisions of the Tender, will be paid for the work the sum specified on the Form of Tender and Agreement subject to such additions and deductions as may properly be made under the terms hereof and subject to the provision that the Municipality may make payments on account monthly or otherwise.

BY \_\_\_\_\_  
Name of Firm or Individual (Hereafter referred to as "The Contractor")

ADDRESS \_\_\_\_\_

\_\_\_\_\_  
Name of Authorized Person Signing for Firm

\_\_\_\_\_  
Signature

\_\_\_\_\_  
Office/Position of Person Signing for Firm

**THE MUNICIPALITY OF SOUTH BRUCE**

\_\_\_\_\_  
STU MOFFAT, MANAGER OF OPERATIONS

Contractor  
Affix  
Corporate Seal

I have the authority to bind the Corporation

# Hot Mix Paving - PW2026 – 3

**Friday, May 15, 2026 @ 1:30 p.m.**

COMPANY	BID BOND/ CHEQUE	SUBTOTAL	HST	TOTAL (incl HST)
Duncor				
Lavis	✓	1,105,315.00 45,420.00	143,690.95 <del>5,904.60</del>	1,249,005.95 51,324.60
Miller Group				
Walker				
MEI				
Drock Paving				
Capital Paving				
Armstrong Paving				
Lavis				

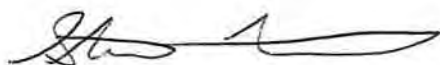
Stu Moffat  

Debbie Kennedy  

Scott Price  

# CCDC 220 – 2024 BID BOND



Bond No.: 7091146-26-0338

Bond Amount: \$-10%-

**Lavis Contracting Co. Limited** as principal, hereinafter called the Principal, and **INTACT INSURANCE COMPANY** a corporation duly authorized to transact the business of Suretyship in all Provinces and all Territories in Canada as surety, hereinafter called the Surety, are held and firmly bound unto **Municipality of South Bruce** as obligee, hereinafter called the Obligee, in the amount of **TEN PERCENT OF THE TENDER PRICE Dollars (\$ -10%- )** lawful money of Canada, for the payment of which sum the Principal and the Surety bind themselves, their heirs, executors, administrators, successors and assigns, jointly and severally.

WHEREAS, the Principal has submitted a written bid to the Obligee, for (Name, Location or Address, and Project Number, if any):  
**PW 2026-3 - Hot Mix Paving**

The condition of this obligation is such that if the Principal shall have the bid accepted within the Validity Period and:

- a) Enters into a formal contract; and,
- b) Gives such bond or bonds as may be specified in the Obligee's bid documents from a Surety duly authorized to transact the business of Suretyship in the jurisdiction of the project,

then this obligation shall be void. Otherwise, provided the Obligee takes all reasonable steps to mitigate the amount of such excess costs, the Principal and the Surety will pay to the Obligee the difference in money between the amount of the bid of the Principal and the amount for which the Obligee legally contracts with another party for the work, supplies and services which were specified in the said bid, if the latter amount be in excess of the former.

The "Validity Period" as used herein shall mean the time period prescribed in the Obligee's bid documents for acceptance of the bid, or, if no time period is specified in the Obligee's bid documents, sixty (60) calendar days from the closing date of the bid.

By agreement between the Principal and the Obligee, the Validity Period may be extended by up to sixty (60) calendar days without notice to the Surety. Further or longer extensions of the Validity Period require prior consent of the Surety.

The Principal and Surety shall not be liable for a greater sum than the Bond Amount.

It is a condition of this bond that any suit or action must be commenced within seven (7) months of the date of this Bond. In the province of Quebec, the coverage period of this bond expires seven (7) months after the date of this Bond.

No right of action shall accrue hereunder to or for the use of any person or corporation other than the Obligee named herein, or the heirs, executors, administrators or successors of the Obligee.

**The Surety:**

**INTACT INSURANCE COMPANY**

(corporate name)

**1100 - 999 W. Hastings St., Vancouver, BC V6C 2W2**

(address)

**N/A**

(fax)

**west.surety@intact.net**

(email)

**The Obligee:**

**Municipality of South Bruce**

(proper name)

**21 Gordon St. East Teeswater, ON N0G 2S0**

(address)

**N/A**

(fax)

**N/A**

(email)

**The Principal:**

**Lavis Contracting Co. Limited**

(corporate name)

**37462A Huron Road, RR #2 Clinton, ON N0M 1L0**

(address)

(fax)

(email)

**IN WITNESS WHEREOF**, the Principal and the Surety have Signed and Sealed this Bond dated **8th** day of **May**, in the year **2026**

SIGNED and SEALED

in the presence of

ATTORNEY IN FACT

Principal



(sign)

Signature

**JEFF MORLEY, OPERATIONS MANAGER**

(name of person signing)

Surety



(sign)

Signature

**SHANNON GASS, Attorney-In-Fact**



## Agreement to Bond

(Surety's Consent)

Consent of Surety No. 7091146-26-0338

To: **Municipality of South Bruce**

Should the tender of: **LAVIS CONTRACTING CO. LIMITED**

For: **PW 2026-3 - Hot Mix Paving**

be accepted within the time period prescribed in the tender, or if no time period is specified, within sixty (60) days from the closing date of tender, and a written contract entered into, we the undersigned do hereby agree to become bound as Surety and will issue

**A Performance Bond equal to 50%**  
**A Labour and Material Payment Bond equal to 50%**

of the tender price guaranteeing faithful performance of said contract.

This Consent of Surety shall cease and be null and void after **thirty (30)** days from the award of contract.

Any suit filed against the Surety with respect to this Surety's Consent must be initiated and duly served on the Surety within seven (7) months of the date hereof.

Tender Date: 15<sup>TH</sup> day of MAY, 2026

Dated: **May 8, 2026**

**INTACT INSURANCE COMPANY**

  
\_\_\_\_\_  
Shannon Gass, Attorney-in-Fact (Seal)

**FORM OF TENDER – Bid Form**

LOCATION		WORK REQUIREMENTS	ESTIMATED QUANTITY	UNIT PRICE	TOTAL PRICE
<b>Municipality of South Bruce (Items A1 to A3)</b>					
#A1	Huron-Bruce Rd (Carrick/ Howick) After bridge @ 911# 1568 to B-Line	Cold Plane existing asphalt 40 mm	50 m2	\$ 43.70	\$ 2,185.00
		Supply and Place HMA padding 15 mm	600 Tonne	\$ 85.50	\$ 51,300.00
		Supply and Place 40 mm surface lift HL3, including Shuttle Buggy (7 m width)	1,300 Tonne	\$ 96.00	\$ 124,800.00
<b>TOTAL - Location #A1</b>					<b>\$ 178,285.00</b>
#A2	Conc. 12E (Carrick) SR 20N to 50 m east of 911# 6 @ bridge	Cold Plane existing asphalt 40 mm	120 m2	\$ 22.00	\$ 2,640.00
		Supply and Place HMA padding 15 mm	1,600 Tonne	\$ 85.50	\$ 136,800.00
		Supply and Place 40 mm surface lift HL3, including Shuttle Buggy (7 m width)	4,400 Tonne	\$ 96.00	\$ 422,400.00
<b>TOTAL - Location #A2</b>					<b>\$ 561,840.00</b>
#A3	Conc. 2 (Culross) West of SR 25S to 200 m west of 911# 2517	Cold Plane existing asphalt 40 mm	120 m2	\$ 19.50	\$ 2,340.00
		Supply and Place HMA padding 15 mm	1,100 Tonne	\$ 85.50	\$ 94,050.00
		Supply and Place 40 mm surface lift HL3, including Shuttle Buggy (7 m width)	2,800 Tonne	\$ 96.00	\$ 268,800.00
<b>TOTAL - Location #A3</b>					<b>\$ 365,190.00</b>

<b>Municipality of South Bruce – Bid Summary</b>		
Item #	Location	Total
#A1	Huron-Bruce Rd (Carrick/Howick)	\$ 178,285.00
#A2	Concession 12E (Carrick)	\$ 561,840.00
#A3	Concession 2 (Culross)	\$ 365,190.00
<b>Subtotal</b>		<b>\$ 1,105,315.00</b>
<b>HST</b>		<b>\$ 143,690.95</b>
<b>Total</b>		<b>\$ 1,249,005.95</b>

LOCATION		WORK REQUIREMENTS	ESTIMATED QUANTITY	UNIT PRICE	TOTAL PRICE
<b>Township of Howick (Item B1)</b>					
#B1	George Street (Gorrie) Victoria St. to Deadend	Cold Plane existing asphalt at various laneway entrances 20 to 40 mm	80 m2	\$ 73.75	\$ 5,900.00
		Supply and Place 40 mm surface lift HL3 (7 m width)	320 Tonne	\$ 123.50	\$ 39,520.00
<b>TOTAL - Location #B1</b>					<b>\$ 45,420.00</b>

<b>Township of Howick – Bid Summary</b>		
Item #	Location	Total
#B1	George Street (Gorrie)	\$45,420.00
	HST	\$ 5,904.60
	<b>Total</b>	<b>\$ 51,324.60</b>

### FORM OF TENDER

Bidders shall list 3 other companies or organizations for which they have completed similar work.

LIST OF REFERENCES			
NAME	ADDRESS	CONTACT	PHONE NO.
SEE ATTACHED PAGE			

Bidders shall list all sub-contractors who they propose to use in the completion of this project.

LIST OF SUB CONTRACTORS		
COMPANY NAME & ADDRESS	CONTACT PERSON	PHONE NO.
OWN FORCES		



A COLAS COMPANY

*Cold In-Place Recycling – Asphalt Paving – Ready Mix Concrete Supply  
Excavating, Grading – Sand, Gravel – Sewer & Watermain*

**37462A HURON RD., RR#2 CLINTON, ONTARIO, N0M 1L0 – PHONE: (519) 482-3694 – FAX: (519) 482-7886 – WWW.LAVIS.CA**

**PROOF OF ABILITY – ASPHALT PAVING**

Reference Organization Name:	Muni. Of Bluewater
Work Performed As:	BW-RDS-01-2025, General Contractor
Brief Project Description/Location:	Airport Line Hot Mix HL4 – 9,410.00t
Total Project Value:	\$1,021,355.00
Reference Contact/Position:	Dave Kester, Manager of Public Works
Reference Email:	publicworks@municipalityofbluewater.ca
Telephone Number:	(519) 236-4351 ext. 221
Project Completion Date:	June 2025

Reference Organization Name:	TWP of Huron-Kinloss
Work Performed As:	Huron Kinloss – 2025 Asphalt Paving, General Contractor
Brief Project Description/Location:	Various Urban Steets in Point Clark & Rual Road Hot Mix HL4 Kinloss Culross – 4,596t
Total Project Value:	\$679,432.85
Reference Contact/Position:	John Yungblut, Director of Public Works
Reference Email:	jyungblut@huronkinloss.com
Telephone Number:	(519) 395-3735 ext. 130
Project Completion Date:	October 2025

Reference Organization Name:	Muni. Of Central Huron
Work Performed As:	CH-2025-004, General Contractor
Brief Project Description/Location:	Milling & Hot Mix Paving Various Urban Streets in Clinton & Rual Roads Summerhill Road HL4 – 13,386.14t
Total Project Value:	\$1,298,970.86
Reference Contact:	Brady Nolan
Reference Email:	bnolan@centralhuron.com
Telephone Number:	(519) 482 -3997 ext.1235
Project Completion Date:	November 2025

Reference Organization Name:	Township of Ashfield-Colborne-Wawanosh
Work Performed As:	ACW – 2025 Asphalt
Brief Project Description/Location:	Various Roads: Supply & Place Hot Mix HL4 – 8,835.00t
Total Project Value:	\$1,032,866.75
Reference Contact:	Thomas McCarthy
Reference Email:	pws@acwtownship.ca
Telephone Number:	(519) 524-4669
Project Completion Date:	November 2025

### FORM OF TENDER - AGREEMENT

I, the undersigned, having carefully examined the Bid Documents, having received, carefully examined and incorporated

Addenda No. \_\_\_\_\_ to No. \_\_\_\_\_

No addenda received

inclusive, and having examined all conditions, circumstances and limitations affecting the work, offer to enter into a contract with the Municipality to perform the work required by the Tender Documents.

#### Declarations

I/We the undersigned, declare that:

1. I/We agree to undertake the work, in compliance with the tender document and specifications for the prices set out in the submitted Form of Tender – Bid Price.
2. No person, firm or corporation other than the undersigned has any personal interest in this bid or in the proposed contract for which this bid is made.
3. This bid is irrevocable and is open for acceptance by the Municipality for a period of **sixty (60) days** from the date of submission.

LAVIS CONTRACTING CO. LTD

Company Name

37462 A HURON RD

Address

CLINTON, ON N0M 1L0

City and Postal Code

(519) 482-3694

Telephone Number

lavis@lavis.ca

Email Address



Authorized Signature

JEFF MORLEY

Name (Print or Type)

OPERATIONS MANAGER

Title

(519) 482-7886

Fax Number

May 15, 2026

Date

I have the authority to bind the Corporation (if applicable).



## Your clearance(s) / Vos certificats de décharge

We confirm that the business(es) listed below are active and in good standing with us.  
Nous confirmons que la ou les entreprises énumérées ci-dessous sont actives et que leurs comptes sont en règle.

Contractor legal or trade name / Raison sociale ou appellation commerciale de l'entrepreneur	Contractor address / Adresse de l'entrepreneur	Contractor NAICS Code and Code Description / Code du SCIAN de l'entrepreneur et description	Clearance certificate number / Numéro du certificat de décharge	Validity period (dd-mmm-yyyy) / Période de validité (jj- mmm-aaaa)
LAVIS CONTRACTING CO. LIMITED / ...	101-281 HILLMOUNT RD, ATTN BILL SCOTT, MARKHAM, ON, L6C2S3, CA	212323: Sand and gravel mining and quarrying 237310: Highway, street and bridge construction 327320: Ready-mix concrete manufacturing 488490: Other support activities for road transportation	A0000JNL6H	20-Feb-2026 to 19-May-2026

Under Section 141 of the *Workplace Safety and Insurance Act*, the WSIB waives our right to hold the principal (the business that has entered into a contractual agreement with the contractor/subcontractor) liable for any unpaid premiums and other amounts the contractor may owe us for the validity period specified.  
Aux termes de l'article 141 de la *Loi sur la sécurité professionnelle et l'assurance contre les accidents du travail*, la WSIB renonce à son droit de tenir l'entrepreneur principal (l'entreprise qui a conclu une entente contractuelle avec l'entrepreneur ou le sous-traitant) responsable de toute prime impayée et autre montant que l'entrepreneur pourrait lui devoir pour la période de validité indiquée.

WSIB Head Office: 200 Front Street West  
Toronto, Ontario, Canada M5V 3J1

Siège social : 200, rue Front Ouest  
Toronto (Ontario) Canada M5V 3J1

1-800-387-0750 | TTY/ATS 1-800-387-0050  
employeraccounts@wsib.on.ca | wsib.ca

**Corporation of the Township of Howick**

**By-law No. 45-2026**

---

**Being A By-Law To Authorize the Entering Into and Execution of an Agreement Between the Corporation of the Township of Howick and Midwestern Equipment (Listowel) Ltd. for the Supply and Delivery of one (1) Roadside Flail Mower**

---

**WHEREAS** Subsection 5(1) of the Municipal Act, S.O. 2001, c. 25 as amended, provides that the powers of a municipality shall be exercised by Council;

**AND WHEREAS** Subsection 5(3) of the Municipal Act, 2001, S.O. 2001, c. 25, as amended, provides that municipal power shall be exercised by By-law;

**NOW THEREFORE IT BE ENACTED** by the Council of the Corporation of the Township Of Howick as follows:

1. That the Corporation of the Township of Howick enter into an Agreement with Midwestern Equipment (Listowel) Ltd., attached hereto as Schedule "A", which forms part of this by-law.
2. That the Reeve and CAO/Clerk are hereby authorized to execute and affix the Corporate Seal to an Agreement between the Corporation of the Township of Howick and Midwestern Equipment (Listowel) Ltd. for the Supply and Delivery of One (1) Roadside Flail Mower.
3. That this By-law shall come into force and take effect upon its final passage.

**Read a first and second time this 16<sup>th</sup> day of June, 2026.**

**Read a third time and finally passed this 16<sup>th</sup> day of June, 2026.**

---

**Reeve Doug Harding**

---

**CAO/Clerk Caitlin Gillis**

## FORM OF TENDER AND AGREEMENT

The Contractor has carefully examined the provisions, plans, specifications and conditions attached to this tender package and has carefully examined the site and locations of the work to be done under this contract and the Contractor understands and accepts the said provisions, plans, specifications and conditions, and for the prices set forth in this tender, hereby offers to furnish all machinery, tools, apparatus and other means of construction, furnish all materials, except as otherwise specified in the contract, and to complete the work in strict adherence to the provisions, plans, specifications and conditions attached to this tender.

It is agreed that the tender quantities are estimated only and may be increased or decreased by the Township of Howick's Manager of Public Works or their designate, without alteration of the contract unit price.

I/We the Contractor hereby certify that we will commence work outlined in the Scope of Work no earlier than \_\_\_\_\_, 2026, and to diligently perform the work continuously without undue delay and further promise to substantially complete the work on or before \_\_\_\_\_, 2026.

This form of Tender and Agreement when signed by the Contractor shall constitute a formal and binding contract when accepted and signed on behalf of the Township of Howick.

Legal Business Name (Successful Bidder)	Address of Successful Bidder
-----------------------------------------	------------------------------

Signature of Authorized Signing Officer (I have the authority to bind the company)	Email
---------------------------------------------------------------------------------------	-------

Name and Title of Signing Officer	Registered Business Number
-----------------------------------	----------------------------

\*\*\*\*\*  
This section for completion on acceptance by the Township of Howick

Signature of Township Officer Affix Corporate Seal	Township Officer Name and Title
-------------------------------------------------------	---------------------------------

Signature of Township Officer	Township Officer Name and Title
-------------------------------	---------------------------------

Acceptance date \_\_\_\_\_, 2026

# RFT PW-2026-03 - RFT PW-2026-03 Roadside Flail Mower

## Vendor Details

Company Name: Midwestern Equipment (Listowel) Ltd.  
Address: 8592 Hwy 23 North  
P.O. Box 93  
Listowel, ON N4W 3H2  
Contact: David Diehl  
Email: dave@midwesternequipment.ca  
Phone: 519-291-2697  
Fax: 519-291-5132  
HST#: R876562745

## Submission Details

Created On: Wednesday May 27, 2026 08:10:46  
Submitted On: Friday May 29, 2026 13:55:10  
Submitted By: David Diehl  
Email: dave@midwesternequipment.ca  
Transaction #: 1f20e1be-3174-4272-9595-ca2d53358d6c  
Submitter's IP Address: 10.1.0.6

---

## Schedule of Prices

The Bidder hereby Bids and offers to enter into the Contract referred to and to supply and do all or any part of the Work which is set out or called for in this Bid, at the unit prices, and/or lump sums, hereinafter stated. HST is additional.

\* Denotes a "MANDATORY" field

Do not enter \$0.00 dollars unless you are providing the line item at zero dollars to the Township (unless otherwise specified).

If the line item and/or table is "NON-MANDATORY" and you are not bidding on it, leave the table and/or line item blank. Do not enter a \$0.00 dollar value.

## Tender Submission

Breakdown of Services	Unit Price *	Quantity	Cost
One, (1) New, Rear Roadside Flail Mower	\$18,899.0000	1	\$ 18,899.00
Delivery, government fees, licensing and all other dealer charges	\$0.0000	1	\$ 0.00
Subtotal:			\$ 18,899.00

## Summary Table

Bid Form	Amount
Tender Submission	\$ 18,899.00
HST (13%)	\$ 2,456.87
Total Contract Amount:	\$ 21,355.87

## Specifications

# Specifications

#	Description	Meets Specifications? *	Specify *	
1	Mower to be rear mounted	<input checked="" type="radio"/> Yes <input type="radio"/> No	Kubota SE2000P	*
2	Mower to be right side cut	<input checked="" type="radio"/> Yes <input type="radio"/> No	Right side	*
3	Mower to be 2026 or newer model year	<input checked="" type="radio"/> Yes <input type="radio"/> No	2026	*
4	Working Width: Mower shall have a minimum cutting width of 78.7" (2m)	<input checked="" type="radio"/> Yes <input type="radio"/> No	78.7 or 200cm	*
5	Operating Angles: Work angle ranging from -65 degrees (downwards) to +90 degrees (upwards)	<input checked="" type="radio"/> Yes <input type="radio"/> No	-65 downward, +90 vertical	*
6	PTO Speed: 540RPM	<input checked="" type="radio"/> Yes <input type="radio"/> No	540	*
7	Rotor Diameter: 450mm (approximately 17.7")	<input checked="" type="radio"/> Yes <input type="radio"/> No	cutting diameter 17.7 inches, 450cm	*
8	Rotor Speed: 1858RPM	<input checked="" type="radio"/> Yes <input type="radio"/> No	1996rpm	*
9	Weight: Approximately 870kg (1918lbs)	<input checked="" type="radio"/> Yes <input type="radio"/> No	1984lbs or 900kgs	*
10	Hitch Type: 3-point hitch - Cat I/II Hitch	<input checked="" type="radio"/> Yes <input type="radio"/> No	3pt and cat 1/11	*
11	Offset ability: Hydraulic pivoting (multi-tilt) allows for a significant offset for ditch maintenance	<input checked="" type="radio"/> Yes <input type="radio"/> No	47.2inches , 1200 mm	*
12	Horsepower Requirement: Designed for operation with a 70-130HP PTO Output	<input checked="" type="radio"/> Yes <input type="radio"/> No	70hp to 130hp	*
13	Transmission: Gearbox with integrated freewheel (rated up to 150 HP) with 5-belt drive	<input checked="" type="radio"/> Yes <input type="radio"/> No	5 belt and 70-130hp	*
14	Rotor Technology: High-speed rotary with heavy-duty hammers (13 per meter)	<input checked="" type="radio"/> Yes <input type="radio"/> No	14/meter	*
15	Roller: Standard 195mm (7.7") diameter rear roller with self-cleaning capabilities and bearing protection.	<input checked="" type="radio"/> Yes <input type="radio"/> No	diameter 7.7 inches, 195mm self cleaning	*
16	Safety & Durability: Features a double skin frame for increased life and hydraulic accumulators to prevent damage upon obstacle collision.	<input checked="" type="radio"/> Yes <input type="radio"/> No	double skin standard	*

## Documents

It is your responsibility to make sure the uploaded file(s) is/are not defective or corrupted and are able to be opened and viewed by the Township. If the attached file(s) cannot be opened or viewed, your Bid Call Document may be rejected.

- [References](#) - KCL\_Flail\_Mower\_Chopper\_SE\_Series\_Brochure\_EN\_Web.pdf - Friday May 29, 2026 13:48:36

# Addenda, Terms and Conditions

The Bidder hereby acknowledges and agrees:

1. To provide all goods, services and construction, as more specifically set out and in accordance with the Township's Bid Call Document, including but not limited to the scope of work, specifications, drawings, Addenda (if issued by the Township), the terms and conditions, etc. stated therein, which are expressly acknowledged and made part of this Contract.
2. This Bid is made without any connections, knowledge, comparison of figures or arrangements with any other company, firm or person making a Bid for the same Work and is in all respects fair and without collusion or fraud.
3. I/WE do hereby Bid and offer to enter into a Contract to do all the Work as specified in the Bid Call Document(s) which shall include all costs but not limited to; freight, duty, currency, etc. in accordance with the prices and terms as submitted by the Bidder herein.
4. If I/WE withdraw this Bid before the formal Contract is executed by the Awarded Bidder for the said Work or Ninety (90) Calendar Days, whichever event first occurs, the amount of the Bid Deposit accompanying this Bid (if applicable to this bid) shall be forfeited to the Township.
5. If the Bid is accepted, I/WE agree to furnish all required documentation, as required by the Bid Call Document(s) within Ten (10) Calendar Days after notification of Award.
6. I/We acknowledge and agree that any issued Addendum/Addenda forms part of the Bid Call Document.

I/WE (including any related or affiliated entities and any principal thereof) have no unresolved litigation with the Township.

I/WE agree to be bound by the terms and conditions and have authority to bind the Corporation and submit this Bid on behalf of the Bidder. - Dave Diehl, Sales, Midwestern Equipment (Listowel) Ltd  
The bidder shall declare any potential conflict of interest that could arise from bidding on this bid. Do you have a potential conflict of interest?  Yes  No

The Bidder acknowledges and agrees that the addendum/addenda below form part of the Bid Document

Please check the box in the column "I have reviewed this addendum" below to acknowledge each of the addenda.

File Name	I have reviewed the below addendum and attachments (if applicable)	Pages
There have not been any addenda issued for this bid.		



For Earth, For Life  
**Kubota**

**SE**

**KUBOTA CHOPPERS**

**SE2000/SE2000P/  
SE3000/SE4000**



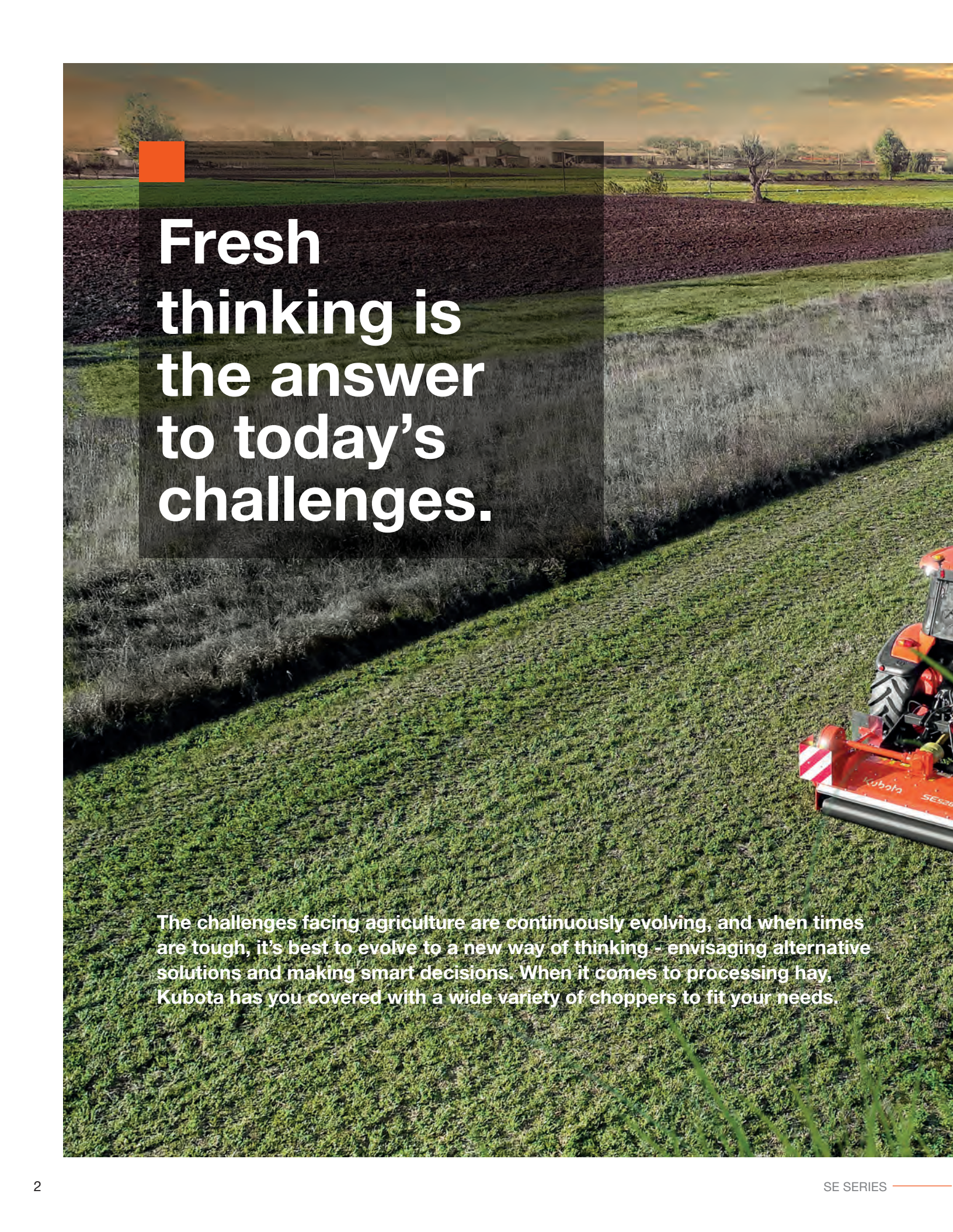

# Fresh thinking is the answer to today's challenges.

The challenges facing agriculture are continuously evolving, and when times are tough, it's best to evolve to a new way of thinking - envisaging alternative solutions and making smart decisions. When it comes to processing hay, Kubota has you covered with a wide variety of choppers to fit your needs.





# SE2000-4000: versatile, reliable and efficient

The extensive range of Kubota choppers ensures there is a model to suit every operating requirement. Each model provides great results in a wide variety of conditions. All models are constructed with a robust gearbox and rugged “V” belt transmission. A high strength body with double plating in critical areas provides further reassurance. A combination of precision engineered rotor shafts and hard wearing blades ensure reliable operation, while keeping maintenance requirements to a minimum.



### SE2000 series

Side pivoting choppers for road maintenance with working widths from 5'1"-6'6" (1.55-2.00m).

### SE2000P series

Side pivoting choppers for road maintenance with working widths from 6'6"-8'2" (2.00-2.50m).



**SE3000 series**

Choppers for green areas and vineyards with working widths from 5'1"-8'2" (1.55-2.50m).

**SE4000 series**

Multipurpose light choppers with working widths from 7'7"-10'7" (2.35-3.25m).



SE2000

# Efficient working: in all conditions

The Kubota SE2000 series is a new multipurpose chopper for road maintenance, clearing out field edges, ditches and hedges. In addition, the SE2000 series shows versatility in operation on grass, light wood and bushes thus being ideal for maintenance of parks, gardens and road sides.



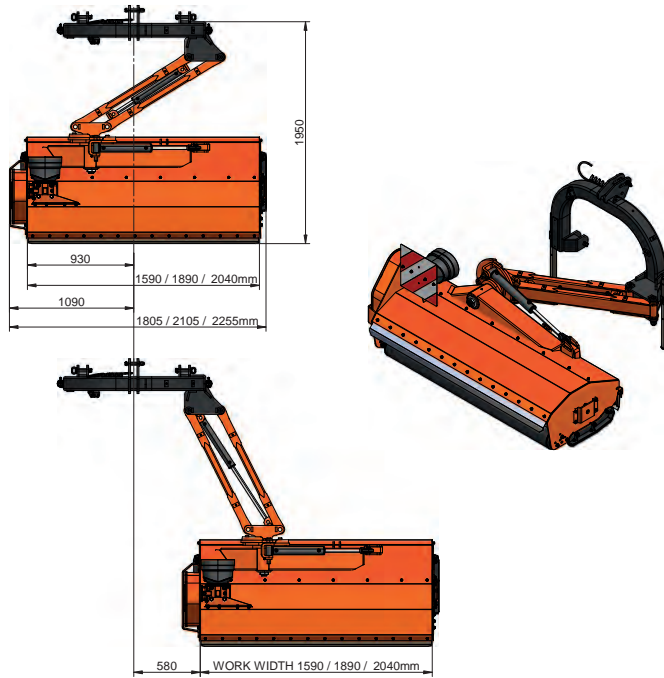

**Offset articulation**

Different offset positions can be reached by different working widths. Versatile in all conditions due to extremely efficient articulation (-65° & +90°).

**Frame**

Solid construction, heavily protected and reinforced with double skin as standard.

**Rotor**

High performance rotor with fast rotation speed, combined with large number of hammer blades (13 per meter) ensure superb chopping performance in all conditions. (universal or rock blades also optionally available).

**Transmission**

Gearbox with freewheel inside and four belts with automatic tensioner ensures smooth and reliable power transmission to the rotor.

**Roller**

Standard 7.7" (195mm) diameter roller with integrated bearings and easy cutting height adjustment.



Maximum versatility - Cutting horizontal.



Vertical.



Banks down to an angle of -65 degrees.



# More offset: more versatility

**Due to the possibility of different working angle positions, the SE2000P series is a highly versatile solution for farm and road maintenance purposes. Compact but robust it offers superb manoeuvrability and provides a high level of reliability.**

## **Compact and easy**

Compared to the standard SE2000 chopper, the plus version offers greater offset 49.4" (1255mm) and reaches positions and working angles impossible to get to with other machines. In addition the SE2000P can be combined with a front mounted chopper (SE4000 series), to maximise working width.

## **Lateral transmission**

Power transmission by gearbox with integrated freewheel (up to 150hp) and five belts which incorporate an automatic tensioner, provide stable rotor speed even when working in tough conditions. A PTO shaft with wide angle joint is fitted as standard equipment.

## **Robust and guarded**

Main frame and parallelogram articulation designed for intensive use and extreme demanding conditions; heavily tested in Kverneland Group Klepp laboratory to ensure reliable and long working life. Gearbox and transmission are protected against misuse during operation.



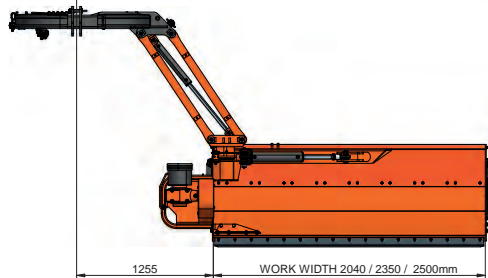
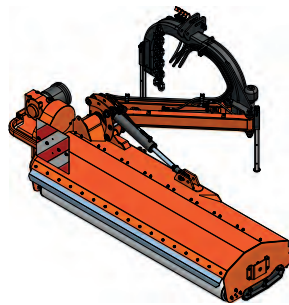
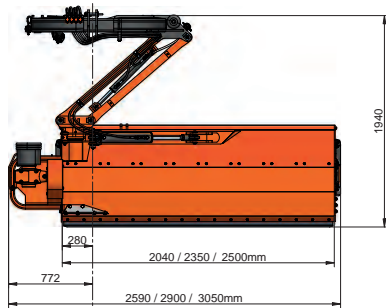

**Offset articulation**

Different offset positions can be reached by different working widths. Versatile in all conditions due to extremely efficient articulation (-65° & +90°).



# Unmatched: efficient and durable

The Kubota SE3000 Chopper is a compact and heavy duty machine for moderately demanding jobs in soft and top fruit orchards, vineyards and light undergrowth. It is also equally at home tidying pasture and other grass fields, chopping straw and stubble.



### **Compact heavy duty machine**

Due to its rugged construction the SE3000 series ensures a long lifetime with minimal maintenance. Adjustable headstock offset up to 19.7" (500mm) gives added versatility for reaching under fruit trees and safer working close to the edges of drainage channels.

As an option, hydraulic adjustment of the offset can be specified. In addition the standard roller and skids support the chopper and provide a consistent working height.

The design of the SE3000 series is modern and versatile; the latest generation rotor can be equipped with different types of blades, making them adaptable to most conditions. Highest rotor speeds (2160rpm) in combination with a counterknife and a double skin, guarantee an excellent shredding effect with minimal power requirement.



The Kubota SE3000 series can be equipped with rake tines to improve chopping on prunings.



A 6.3" (160mm) diameter roller with an adjustable scraper is fitted as standard equipment and ensures correct field performance.



# Multi-purpose: Front, rear or offset

**Multi-purpose - for chopping grass, pasture, set-aside land and stubble. A strong double headstock allows mounting the machine in front or behind the tractor. Together with the hydraulic offset feature, it gives multi purpose versatility for nearly all conditions e.g. clearing out field edges, orchards, road edges. All SE Choppers come standard with hammer blades.**

## Hydraulic Offset

Ideal for clearing out field edges. Versatile use also for road maintenance. The precisely aligned offset frame machined after the welding process ensures strong and reliable guidance.

Greasable nylon bushes ensure a long lifetime.



## Auto-alignment

The central gearbox fitted into the headstock ensures that the pto-shaft remains at the same angle in all working positions. Even on max. 19.7" (500mm) offset the pto angle does not change. This guarantees a smooth drive, reduced wear and a longer lifetime of the pto shaft and the whole driveline (crosses and yokes).

## Rear roller

Standard equipment for reliable depth control in all conditions. Ø 6.3" (160mm) with 1.8" (45mm) bearing hub and greasable ball bearings. Replaceable integrated bearing housing. Roller interchangeable with skids.





**Headstock**

The heavy duty headstock is well proven with the design taken from the Kubota Power Harrow range.



**Lateral Driven**

Drive by five VX type V-belts running on invertible pulleys which allows adaptation for 540 or 1000 rpm drive. Idler wheel with automatic tensioner spring always ensures stable and low wear on belt drive.



**Counter Knives and Double Skin**

One standard U-counter knife. A second U-counter knife is available (optional equipment) for more intense shredding and heavy conditions. Also combinable with double skin.



Hammer blades

# Technical data

Model	SE2000				SE2000P		
		Side Pivoting Choppers			Side Pivoting Choppers		
<b>Dimensions &amp; Weight</b>							
Working width	inch (cm)	61 (155)	72.8 (185)	78.7 (200)	78.7 (200)	90.6 (230)	98.4 (250)
Transport width	inch (cm)	70.9 (180)	82.7 (210)	88.6 (225)	100.4 (255)	112 (285)	120 (305)
Weight	lbs (kg)	1631 (740)	1720 (780)	1808 (820)	1984 (900)	2116 (960)	2172 (985)
<b>Attachment to tractor</b>							
Pto input speed	(rpm)	540			540		
Min-Max. power requirem.	(hp)	45 - 100			70 - 130		
<b>Operation</b>							
No. of universal blades		40	48	52	52	60	64
No. of hammer blades		20	24	26	26	30	32
Rotor speed	(rpm)	1800			1858		
Blade tip speed	(m/s)	43			44		
Rotor shaft diameter	inch (mm)	2 (50)			2 (50)		
Rotor diameter	inch (mm)	6.7 (169)			6.7 (169)		
Cutting diameter	inch (mm)	17.8 (452)			17.8 (452)		
No. of belts		5			5		
Belt tensioner		automatic			automatic		
<b>Equipment</b>							
Offset	inch (mm)	22.8 (580)			49.2 (1250)		
Rear roller	inch (mm)	7.7 (195) ●			7.7 (195) ●		
Rear wheels		-	-	-	-	-	-
Skids		●	●	●	●	●	●
I counter knife		●	●	●	●	●	●
II counter knife		○	○	○	○	○	○
Double skin		●	●	●	●	●	●

- not available ○ option ● standard

Model	SE2000				SE2000P		
		Side Pivoting Choppers			Side Pivoting Choppers		
<b>Blades</b>							
Hammer blades		●			●		

SE3000					SE4000			
Choppers for Green Area and Vineyards					Multipurpose choppers			

61 (155)	72.8 (185)	78.7 (200)	90.6 (230)	98.4 (250)	92.5 (235)	110.2 (280)	128 (325)	
69.7 (177)	81.5 (207)	87.4 (222)	99.2 (252)	107 (272)	100.4 (255)	118.1 (300)	96.5 (345)	
1047 (475)	1191 (540)	1261 (572)	1367 (620)	1444 (655)	1903 (863)	2161 (980)	2381 (1080)	

540					540 or 1000			
35 - 80					60 - 140			

40	48	52	60	64	40	48	56	
20	24	26	30	32	20	24	28	
2160					1730 - 1828			
51					46 - 48			
2 (50)					2.4 (60)			
6.7 (169)					8.7 (220)			
17.8 (452)					19.8 (503)			
5					5			
automatic					automatic			

19.7 (500)					19.7 (500)			
6.3 (160) ●					7.7 (195) ●			
-	-	-	-	-	○	○	○	
●	●	●	●	●	●	●	●	
●	●	●	●	●	●	●	●	
○	○	○	○	○	○	○	○	
●	●	●	●	●	○	○	○	

SE3000					SE4000			
Choppers for Green Area and Vineyards					Multipurpose choppers			

●					●			
---	--	--	--	--	---	--	--	--

*Descriptions, specifications, images, colours and accessories contained in this brochure are based on information believed to be correct at the time this publication was approved for printing. Although descriptions, specifications, images, colours and accessories are believed to be correct, accuracy cannot be guaranteed. Errors and omissions excepted. Kubota Canada Ltd. reserves the right to change the stated specifications, colours and accessories without notice. Some items shown may be optional and some products shown may not be available at all dealerships. This brochure is for informational purposes only. To the fullest extent permitted by law, Kubota disclaims all representations and warranties, express or implied, as well as any liability from the use of this brochure. For complete warranty, safety and product information, consult your local Kubota dealer and the operator's manual. Power (HP/KW) and other specifications are based on various standards or recommended practices. For your safety, Kubota strongly recommends the use of a Rollover Protective Structure (ROPS) and seat belt in almost all applications. This brochure is intended for the Canadian market only. For information regarding Kubota products or services outside these areas, see Kubota Corporation's global website. Kubota does not provide parts, warranty or service for any product which is re-sold or retailed in any country other than the country for which the product(s) were designed or manufactured.*

©2023 Kubota Canada Ltd.



## **KUBOTA CANADA LTD.**

Kubota Canada Ltd.

Head office: 1155 Kubota Drive, Pickering, Ontario, L1X 0H4

Visit our web site at: [www.kubota.ca](http://www.kubota.ca)

SE2000/SE4000EN-01. Printed 04.2023

**Corporation of the Township of Howick**

**By-law No. 46-2026**

---

**A By-law to confirm the proceedings of Council of the Corporation of the Township of Howick**

---

**Whereas**, in accordance with the Municipal Act, 2001, S. O. 2001, Section 5(1), the powers of a municipal Corporation shall be exercised by its Council; and

**Whereas**, Section 5(3) of the Municipal Act, 2001, prescribes that the powers of every Council shall be exercised by by-law unless the municipality is specifically authorized to do otherwise; and

**Whereas**, it is deemed expedient that the proceedings of the Council of the Corporation of the Township of Howick be confirmed and adopted by by-law;

**Now therefore**, the Council of the Corporation of the Township of Howick enacts as follows:

1. That the actions and decisions of the Council of the Corporation of the Township of Howick at its regular Council meeting held June 16, 2026 in respect to each resolution and other action taken by the Council of the Corporation of the Township of Howick at these meetings, except where the prior approval of the Ontario Municipal Board is required, is hereby adopted, ratified and confirmed.
2. That the Reeve and proper officials of the Corporation of the Township of Howick are hereby authorized and directed to do all things necessary to give effect to the actions of the Council of the Corporation of the Township of Howick referred to in the proceedings section hereof.
3. That the Reeve and the Clerk, unless otherwise specified, are authorized and directed to execute all documents necessary in that behalf and to affix thereto the seal of the Corporation of the Township of Howick.
4. This by-law shall come into force and takes effect on the date of its final passing.

**Read a first and second time this 16<sup>th</sup> day of June, 2026.**

**Read a third time and finally passed this 16<sup>th</sup> day of June, 2026.**

---

**Reeve, Doug Harding**

---

**CAO/Clerk, Caitlin Gillis**